

DOCUMENT 118-99

**TEST METHODS FOR TELEMETRY
SYSTEMS AND SUBSYSTEMS**

**VOLUME III
TEST METHODS FOR RECORDER/REPRODUCER
SYSTEMS AND MAGNETIC TAPE**

**WHITE SANDS MISSILE RANGE
KWAJALEIN MISSILE RANGE
YUMA PROVING GROUND
DUGWAY PROVING GROUND
ABERDEEN TEST CENTER
NATIONAL TRAINING CENTER**

**ATLANTIC FLEET WEAPONS TRAINING FACILITY
NAVAL AIR WARFARE CENTER WEAPONS DIVISION
NAVAL AIR WARFARE CENTER AIRCRAFT DIVISION
NAVAL UNDERSEA WARFARE CENTER DIVISION, NEWPORT
PACIFIC MISSILE RANGE FACILITY
NAVAL UNDERSEA WARFARE CENTER DIVISION, KEYPORT**

**30TH SPACE WING
45TH SPACE WING
AIR FORCE FLIGHT TEST CENTER
AIR FORCE DEVELOPMENT TEST CENTER
AIR WARFARE CENTER
AIR ARMAMENT CENTER
GOLDWATER RANGE
UTAH TEST AND TRAINING RANGE**

**DISTRIBUTION A: APPROVED FOR PUBLIC RELEASE;
DISTRIBUTION IS UNLIMITED**

DOCUMENT 118-99

**TEST METHODS FOR TELEMETRY
SYSTEMS AND SUBSYSTEMS**

**TEST METHOD FOR RECORDER/REPRODUCER SYSTEMS
AND MAGNETIC TAPE
VOLUME III**

JANUARY 1999

Prepared by

**TELEMETRY GROUP
RANGE COMMANDERS COUNCIL**

Published by

**Secretariat
Range Commanders Council
U.S. Army White Sands Missile Range
New Mexico 88002-5110**

TABLE OF CONTENTS

	<u>Page</u>
ACRONYMS	xiii
INTRODUCTION	xiv
CHAPTER 1 LONGITUDINAL FIXED HEAD RECORDING TESTS	1-1
1.3.1 Purpose.....	1-1
1.3.2 Test Equipment.....	1-1
1.3.3 Test Method.	1-1
1.3.3.1 Setup..	1-1
1.3.3.2 Conditions.....	1-1
1.3.3.3 Procedure.	1-1
1.3.3.4 Data Reduction.....	1-2
1.4 Record Head-Stack Azimuth Alignment (1).....	1-2
1.4.1 Purpose.....	1-2
1.4.2 Test Equipment.....	1-2
1.4.3 Test Method.	1-3
1.4.3.1 Setup.	1-3
1.4.3.2 Conditions.....	1-3
1.4.3.3 Procedure.	1-3
1.4.3.4 Data Reduction.....	1-4
1.5 Reproduce Head-Stack Azimuth Alignment (1) and (2)	1-4
1.5.1 Purpose.....	1-4
1.5.2 Test Equipment.....	1-4
1.5.3 Test Method.	1-5
1.5.3.1 Setup..	1-5
1.5.3.2 Conditions.....	1-5
1.5.3.3 Procedure.	1-5
1.5.3.4 Data Reduction.....	1-5
1.6 Tape Speed Tests	1-5
1.6.1 General.....	1-5
1.6.2 Tape Speed (1).. ..	1-5
1.6.3 Purpose.....	1-5
1.6.4 Test Equipment	1-6
1.6.5 Test Method.	1-6
1.6.5.1 Setup.	1-6
1.6.5.2 Conditions.....	1-6
1.6.5.3 Procedure.	1-6
1.6.5.4 Data Reduction.....	1-7
1.7 Speed Variation and Timing Error Tests	1-7

	<u>Page</u>
1.7.1	Flutter Measurement Test (1) and (2)..... 1-7
1.7.1.1	Purpose..... 1-7
1.7.1.2	Test Equipment. 1-7
1.7.1.2.1	Oscillator..... 1-7
1.7.1.2.2	Carrier Band-Pass Filter..... 1-7
1.7.1.2.3	Frequency Discriminator 1-7
1.7.1.2.4	Flutter Band-Pass Filter 1-8
1.7.1.2.5	Statistical Voltmeter..... 1-8
1.7.1.3	Test Method 1-8
1.7.1.3.1	Procedure. 1-8
1.7.1.3.2	Data Reduction..... 1-10
1.7.2	Time Base Error Test (1) and (2)..... 1-11
1.7.2.1	Purpose..... 1-11
1.7.2.2	Test Equipment.. 1-11
1.7.2.3	Test Method.. 1-11
1.7.2.3.1	Procedure. 1-11
1.7.2.3.2	Data Reduction..... 1-14
1.7.3	Interchannel Time Displacement Error Test (1) and (2)..... 1-14
1.7.3.1	Purpose..... 1-14
1.7.3.2	Test Equipment. 1-14
1.7.3.3	Test Method.. 1-14
1.7.3.3.1	Procedure.. 1-14
1.7.3.3.2	Data Reduction..... 1-16
1.8	Direct Record System Tests..... 1-17
1.8.1	General..... 1-17
1.8.2	Bias, Record Level and Second Harmonic Distortion Tests (1) and (2). 1-17
1.8.2.1	Purpose..... 1-17
1.8.2.2	Test Equipment. 1-17
1.8.2.2.1	Oscillator..... 1-17
1.8.2.2.2	Voltmeter.. 1-17
1.8.2.2.3	Wave Analyzer (Frequency Selective Voltmeter). 1-17
1.8.2.3	Test Method. 1-17
1.8.2.3.1	Setup. 1-17
1.8.2.3.2	Conditions..... 1-17
1.8.2.3.3	Procedure. 1-17
1.8.2.3.4	Data Reduction..... 1-18
1.8.3	Frequency Response (Direct Recording) Test (1) and (2). 1-18
1.8.3.1	Purpose..... 1-18
1.8.3.2	Test Equipment 1-18
1.8.3.3	Test Method. 1-18
1.8.3.3.1	Setup 1-19
1.8.3.3.2	Conditions..... 1-19
1.8.3.3.3	Procedure. 1-19
1.8.3.3.4	Data Reduction..... 1-19

	<u>Page</u>
1.8.4	Signal-to-Noise Ratio Tests 1-19
1.8.4.1	Purpose..... 1-19
1.8.4.2	Test Equipment. 1-19
1.8.4.3	Test Method. 1-19
1.8.4.3.1	Wide Band SNR (1) and (2)..... 1-19
1.8.4.3.1.1	Setup. 1-19
1.8.4.3.1.2	Conditions. 1-20
1.8.4.3.1.3	Procedure. 1-20
1.8.4.3.1.4	Data Reduction..... 1-20
1.8.4.4	Slot (1). 1-20
1.8.4.5	Data Reduction..... 1-20
1.8.5	Intermodulation Distortion Test (1) 1-20
1.8.5.1	Purpose..... 1-20
1.8.5.2	Test Equipment. 1-21
1.8.5.3	Procedure. 1-21
1.8.5.4	Data Reduction..... 1-21
1.8.6	Crosstalk Test (1)..... 1-22
1.8.6.1	Purpose..... 1-22
1.8.6.2	Test Equipment.. 1-22
1.8.6.3	Test Method. 1-22
1.8.6.3.1	Setup 1-22
1.8.6.3.2	Conditions..... 1-22
1.8.6.3.3	Procedure. 1-22
1.8.6.3.4	Data Reduction..... 1-23
1.8.7	Bias Leakage Test (1). 1-23
1.8.7.1	Purpose..... 1-23
1.8.7.2	Test Equipment.. 1-23
1.8.7.3	Test Method. 1-23
1.8.7.3.1	Setup. 1-23
1.8.7.3.2	Conditions. 1-23
1.8.7.3.3	Procedure. 1-23
1.8.7.3.4	Data Reduction..... 1-24
1.8.8	Multispeed Record Level Test (1). 1-24
1.8.8.1	Purpose..... 1-24
1.8.8.2	Test Equipment.. 1-24
1.8.8.3	Test Method. 1-24
1.8.8.3.1	Setup 1-24
1.8.8.3.2	Conditions..... 1-24
1.8.8.3.3	Procedure. 1-24
1.8.8.3.4	Data Reduction..... 1-24
1.8.9	Record Transfer Characteristic Test (1)..... 1-25
1.8.9.1	Purpose..... 1-25
1.8.9.2	Test Equipment.. 1-25

	<u>Page</u>
1.8.9.3	Test Method. 1-25
1.8.9.3.1	Setup.. 1-25
1.8.9.3.2	Conditions. 1-25
1.8.9.3.3	Procedure. 1-25
1.8.9.3.4	Data Reduction..... 1-25
1.8.10	Eye Pattern (1). 1-26
1.8.10.1	Purpose.. 1-26
1.8.10.2	Test Equipment..... 1-26
1.8.10.3	Test Method. 1-26
1.8.10.3.1	Setup. 1-26
1.8.10.3.2	Conditions..... 1-26
1.8.10.3.3	Procedure 1-26
1.8.10.3.4	Data Reduction..... 1-28
1.9	FM System Tests..... 1-30
1.9.1	General..... 1-30
1.9.2	Deviation, Center Frequency And Polarity Tests (1) and (2). 1-30
1.9.2.1	Purpose..... 1-30
1.9.2.2	Test Equipment 1-30
1.9.2.3	Test Method. 1-30
1.9.2.3.1	Setup.. 1-30
1.9.2.3.2	Conditions 1-30
1.9.2.3.3	Procedure: 1-30
1.9.2.3.4	Data Reduction..... 1-31
1.9.3	Frequency Response Test (1) and (2). 1-31
1.9.3.1	Purpose..... 1-31
1.9.3.2	Test Equipment 1-31
1.9.3.3	Test Method. 1-31
1.9.3.3.1	Setup. 1-31
1.9.3.3.2	Conditions. 1-31
1.9.3.3.3	Procedure. 1-31
1.9.3.3.4	Data Reduction..... 1-32
1.9.4	Signal-To-Noise Ratio Test (1) and (2). 1-32
1.9.4.1	Purpose..... 1-32
1.9.4.2	Test Equipment 1-32
1.9.4.3	Test Method. 1-32
1.9.4.3.1	Setup. 1-32
1.9.4.3.2	Conditions 1-32
1.9.4.3.3	Procedure 1-32
1.9.4.3.4	Data Reduction..... 1-32
1.9.5	Distortion Test (1) and (2). 1-32
1.9.5.1	Purpose..... 1-32
1.9.5.2	Test Equipment..... 1-32
1.9.5.3	Test Method. 1-33
1.9.5.3.1	Setup. 1-33

	<u>Page</u>
1.9.5.3.2	Conditions 1-33
1.9.5.3.3	Procedure 1-33
1.9.5.3.3.1	Single Component Distortion 1-33
1.9.5.3.3.2	Intermodulation Distortion..... 1-33
1.9.5.3.4	Data Reduction..... 1-33
1.9.6	Spurious Component Test (1) 1-33
1.9.6.1	Purpose..... 1-33
1.9.6.2	Test Equipment 1-33
1.9.6.3	Test Method 1-33
1.9.6.3.1	Setup 1-33
1.9.6.3.2	Conditions 1-33
1.9.6.3.3	Procedure 1-34
1.9.6.3.4	Data Reduction..... 1-34
1.9.7	Linearity Tests (dc) (1). 1-34
1.9.7.1	Purpose..... 1-34
1.9.7.2	Test Equipment. 1-34
1.9.7.3	Test Method 1-34
1.9.7.3.1	Setup 1-34
1.9.7.3.2	Conditions 1-34
1.9.7.3.3	Procedure 1-34
1.9.7.3.3.1	FM Record Amplifier Linearity 1-35
1.9.7.3.3.2	FM Reproduce Amplifier Linearity 1-35
1.9.7.3.4	Data Reduction..... 1-35
1.9.8	Drift (dc) at Center Frequency Test (1) 1-35
1.9.8.1	Purpose..... 1-36
1.9.8.2	Test Equipment. 1-36
1.9.8.3	Test Method 1-36
1.9.8.3.1	Setup. 1-36
1.9.8.3.2	Conditions 1-36
1.9.8.3.3	Procedure 1-36
1.9.8.3.4	Data Reduction..... 1-36
1.9.9	Multispeed Reproduce Transfer Levels Test (1) 1-36
1.9.9.1	Purpose..... 1-36
1.9.9.2	Test Equipment. 1-36
1.9.9.3	Test Method 1-36
1.9.9.3.1	Setup 1-37
1.9.9.3.2	Conditions 1-37
1.9.9.3.3	Procedure 1-37
1.9.9.3.4	Data Reduction..... 1-37
CHAPTER 2	SERIAL HIGH DENSITY DIGITAL RECORDING TESTS 2-1
2.1	General..... 2-1
2.2	Basic Serial HDDR Test (1) and (2)..... 2-1

	<u>Page</u>
2.2.1	Purpose..... 2-1
2.2.2	Test Equipment..... 2-1
2.2.3	Test Method..... 2-1
2.2.3.1	Setup..... 2-1
2.2.3.2	Conditions..... 2-2
2.2.3.3	Procedure..... 2-3
2.2.3.4	Data Reduction..... 2-3
2.3	Speed Ratio Test (1)..... 2-3
2.3.1	Purpose..... 2-3
2.3.2	Test Equipment..... 2-3
2.3.3	Test Method..... 2-3
2.3.3.1	Setup... .. 2-3
2.3.3.2	Conditions..... 2-3
2.3.3.3	Procedure..... 2-5
2.3.3.4	Data Reduction..... 2-5
2.4	Signal-to-Noise Ratio Margin Test (Using Input Attenuator) (1)..... 2-5
2.4.1	Purpose..... 2-5
2.4.2	Test Equipment..... 2-5
2.4.3	Test Method..... 2-5
2.4.3.1	Setup..... 2-5
2.4.3.2	Conditions..... 2-7
2.4.3.3	Procedure..... 2-7
2.4.3.4	Data Reduction..... 2-9
2.5	Signal-to-Noise Ratio Margin Test (Using Additive Noise) (1)..... 2-9
2.5.1	Purpose..... 2-9
2.5.2	Test Equipment..... 2-9
2.5.3	Test Method..... 2-9
2.5.3.1	Setup..... 2-9
2.5.3.2	Conditions..... 2-9
2.5.3.3	Procedure..... 2-9
2.5.3.4	Data Reduction..... 2-12
2.6	Serial HDDR PCM Bit Synchronizer Test (1)..... 2-13
2.6.1	Purpose..... 2-13
2.6.2	Test Equipment..... 2-13
2.6.3	Test Method..... 2-13
2.6.3.1	Setup..... 2-13
2.6.3.2	Conditions..... 2-14
2.6.3.3	Procedure..... 2-15
2.6.3.4	Data Reduction..... 2-15
CHAPTER 3	DIGITAL CASSETTE HELICAL SCAN RECORDING TESTS..... 3-1
3.1	General..... 3-1
3.2	Calibration Tape (1)..... 3-1

	<u>Page</u>
3.2.1	19-mm ID-1 Systems..... 3-1
3.2.2	One-half inch S-VHS Systems..... 3-1
3.3	Bit Error Rate (BER) Test (1) and (2) 3-2
3.3.1	Test Equipment..... 3-2
3.3.2	Procedure..... 3-2
3.3.3	Data Reduction..... 3-2
3.4	Time Scaled Playback Test (1) and (2)..... 3-3
3.4.1	Test Equipment..... 3-3
3.4.2	Procedure..... 3-3
3.4.3	Data Reduction..... 3-3
3.5	Polarity Test (1) 3-3
3.5.1	Test Equipment..... 3-3
3.5.2	Procedure..... 3-3
3.5.3	Data Reduction..... 3-3
3.6	Eye Pattern (1) 3-3
3.6.1	Test Equipment..... 3-3
3.6.2	Procedure..... 3-4
3.6.3	Data Reduction..... 3-4
3.7	Longitudinal Track Tests (1) and (2)..... 3-4
3.7.1	Test Equipment..... 3-4
3.7.2	Procedure..... 3-4
3.7.3	Data Reduction..... 3-5
CHAPTER 4	RECORDER MULTIPLEXER/DEMULTIPLEXER SYSTEM TESTS..... 4-1
4.1	General..... 4-1
4.2	Bit Error Rate Test (1) and (2)..... 4-1
4.2.1	General..... 4-1
4.2.2	Test Equipment..... 4-1
4.2.3	Procedure..... 4-1
4.2.4	Data Reduction..... 4-1
4.3	Delay Measurements (1)..... 4-1
4.3.1	Purpose..... 4-1
4.3.2	Test Equipment..... 4-2
4.3.3	Test Method..... 4-2
4.3.3.1	Setup..... 4-2
4.3.3.2	Conditions..... 4-2
4.3.3.3	Procedure..... 4-2
4.3.3.4	Data Reduction..... 4-3
4.4	Format Verification Test (1)..... 4-5
4.4.1	General..... 4-5
4.4.2	Test Equipment..... 4-5
4.4.3	Procedure..... 4-5
4.4.4	Data Reduction..... 4-5

	<u>Page</u>
CHAPTER 5 MAGNETIC TAPE TESTS.....	5-1
5.1 General.....	5-1
5.2 Manufacturer's Centerline Tape (MCT) and Manufacturer's Secondary Centerline Tape (MSCT)	5-1
5.3 Longitudinally-Oriented Oxide Instrumentation Magnetic Tape	5-2
5.3.1 Standard Record Conditions.	5-2
5.3.1.1 High Energy Tape	5-2
5.3.1.2 High Resolution Tape..	5-2
5.3.2 Working Tape Length	5-2
5.3.3 Test Equipment-Level Detector and Recorder..	5-2
5.3.4 Level Detector.....	5-2
5.3.5 Direct-Write Recorder..	5-2
5.3.6 Durability Test Analysis Consists of	5-3
5.3.7 Output Uniformity Test Analysis Consists of.....	5-3
5.3.8 Test Procedures, Magnetic/Electrical Characteristics.....	5-3
5.3.8.1 Bias Level.	5-3
5.3.8.2 Record Level.....	5-4
5.3.9 Wavelength Response and Output at 0.1 Upper Band Edge Wavelengths.....	5-4
5.3.10 Short Wavelength Output Uniformity.	5-5
5.3.11 Short Wavelength Instantaneous Non-Uniformity (Dropout).	5-7
5.3.12 Durability.	5-7
5.3.13 Modulation Noise.....	5-9
5.3.14 Layer-to-Layer Signal Transfer.	5-9
5.3.15 Ease of Erasure.	5-10
5.3.16 Physical Characteristics.	5-10
5.4 Digital Cassette Tape	5-10
5.4.1 Standard Record/Reproduce Conditions.....	5-11
5.4.2 Bit Error Rate Test.	5-11
5.4.2.1 General.....	5-11
5.4.2.2 Test Equipment	5-11
5.4.2.3 Procedure.	5-11
5.4.2.4 Data Reduction.....	5-11
5.4.3 Sensitivity.	5-11
5.4.3.1 Purpose.....	5-12
5.4.3.2 Procedure..	5-12
5.4.3.3 Data Reduction.....	5-12
5.4.4 Signal-to-Noise Ratio (SNR).	5-12
5.4.4.1 Purpose.....	5-12
5.4.4.2 Procedure	5-12
5.4.4.3 Data Reduction.....	5-12

LIST OF TABLES

<u>Table</u>		<u>Page</u>
1-1	Flutter Band-Pass Filter Characteristics.....	1-10
1-2	IMD Test Frequencies.....	1-22
5-1	Wavelengths for Wavelength Response Tests.....	5-5

LIST OF FIGURES

<u>Figure No.</u>		<u>Page</u>
CHAPTER 1-LONGITUDINAL FIXED HEAD RECORDING TESTS		
1-1	Typical waveform obtained from head polarity test.....	1-2
1-2	Lissajous oscilloscope patterns.....	1-4
1-3	Tape speed – general or field use method.....	1-6
1-4	Flutter measurement.....	1-8
1-5	Flutter measurement using commercially available integrated test set.....	1-9
1-6	Time base error measurement.....	1-12
1-7	Time base error measurement using integrated commercially available test set.....	1-13
1-8	Interchannel time displacement error measurement.....	1-15
1-9	Interchannel time displacement error measurement using integrated commercially available test set.....	1-16
1-10	Frequency response and signal-to-noise ratio.....	1-18
1-11	Intermodulation distortion test.....	1-21
1-12	Eye pattern test setup.....	1-26
1-13	Good NRZ eye pattern.....	1-27
1-14	Good bi-phase eye pattern.....	1-27
1-15	Poor NRZ eye pattern.....	1-27
1-16	Poor bi-phase eye pattern.....	1-28
1-17	FM system test equipment setup.....	1-31
1-18	Linearity (dc) curves.....	1-38
CHAPTER 2-SERIAL HIGH DENSITY RECORDING TESTS		
2-1	Test setup for basic serial HDDR test.....	2-2
2-2	Test setup for SNR margin test (Attenuation Method).....	2-7
2-3	Test setup for SNR margin test (using additive noise).....	2-10
2-4	Circuit for specially conditioning white noise.....	2-13
2-5	Test setup for serial HDDR PCM bit synchronizer test.....	2-14

<u>Figure No.</u>	<u>Page</u>
CHAPTER 3-DIGITAL CASSETTE HELICAL SCAN RECORDING TESTS	
3-1 Digital recorder longitudinal track test.....	3-5
CHAPTER 4-RECORDER MULTIPLEXER/DEMULTIPLEXER SYSTEM TESTS	
4-1 Multiplexer/demultiplexer delay measurement	4-2
CHAPTER 5-MAGNETIC TAPE TESTS	
5-1 Output uniformity test analysis.....	5-6
5-2 Durability test analysis.....	5-8

LIST OF DATA SHEETS

<u>DATA SHEET NO.</u>	<u>Page</u>
CHAPTER 1-LONGITUDINAL FIXED HEAD RECORDING TESTS	
1-1 Eye Pattern	1-29
CHAPTER 2-SERIAL HIGH DENSITY RECORDING TESTS	
2-1 Basic Serial HDDR.....	2-4
2-2 Speed Ratio	2-6
2-3 Signal-to-Noise Ratio Margin (with attenuation)	2-8
2-4 Signal-to-Noise Ratio Margin (with additive noise).....	2-11
2-5 PCM Bit Synchronizer	2-16
CHAPTER 4 RECORDER MULTIPLEXER/DEMULTIPLEXER SYSTEM TESTS	
4-1 Delay Measurements.....	4-4

ACRONYMS

ADARIO	Analog to Digital Adaptable Recorder Input/Output
ANSI	American National Standards Institute
BER	bit-error rate
CBER	corrected BER
CCT	Crossplay Calibration Tape
CRT	Cathode Ray Tube
CSR	clock-slip rate
dB	decibel
dBm	decibels above 1 milliwatt
dc	direct current
EDAC	Error Detection and Correction
FM	frequency modulation
GPS	Global Positioning System
HDD	High Density Digital
HDDR	high density digital recording
HE	high energy
HR	high resolution
Hz	hertz
IBM	International Business Machines
IMD	intermodulation distortion
ips	inches per second
IRIG	Interrange Instrumentation Group
ITDE	interchannel time displacement error
Kbps	Kilobits per seconds
kHz	Kilohertz
MCT	Manufacturer's Centerline Tape
MHz	Megahertz
MML	Magnetic Media Laboratory
MSCT	Manufacturer's Secondary Centerline Tape
Mbps	megabits per second
NPR	Noise Power Ratio
NRZ	non-return to zero
NRZ-L	non-return to zero level
PBN	principal block numbers
PC	Personal Computer
PCM	pulse code modulation
PN	Pseudo-noise
RC	resistor capacitor
rms	root mean square
RMS	
RNRZ-L	randomized non-return-to-zero-level
SNR	signal-to-noise ratio
SR	standard resolution
S-VHS	super VHS
TBE	time base error
UBE	upper band edge
V rms	volts root mean square
VLDS	very large data store
VSG	Verification Signal Generator

INTRODUCTION

This volume describes the procedures used in measuring and where applicable, adjusting the performance parameters of recorder/reproducer systems and magnetic tapes to insure compatibility and uniformity. Definitions of terms applicable to these procedures are found in IRIG Standard 106-Telemetry Standards, Chapters 6 and 7.

These procedures include wideband and double density instrumentation magnetic tape (longitudinal fixed head) recorder/reproducer systems using 1-inch (25.4-mm) wide tape and helical scan digital recorders when tested as complete systems. It also includes multiplexer/demultiplexer systems used as inputs/outputs of the digital recorders. Tests of components such as heads and capstan motors are beyond the scope of these procedures. The magnetic tape procedures include tests of electrical characteristics of longitudinally oriented oxide magnetic tape designed for instrumentation recording, including high resolution, high density digital, and high energy tapes. Performance tests of cassette tapes for helical scan digital recording systems are at the systems level.

Before starting these procedures, qualitative performance tests should be conducted to ensure that the system will transport tape and is capable of recording and reproducing the appropriate signals, and that the system is aligned in accordance with the standards contained in Chapter 6 of IRIG Standard 106 and the appropriate system instruction manual. When measurement techniques are not specified, commonly accepted measurement methods for mechanical and electrical characteristics should be employed. These tests may be conducted and data processed either manually or via computer where available.

Procedures are included for acceptance and operational readiness tests of recorder/reproducer systems. Not all tests are required for any one system, and tests other than those indicated may be required for a given system, depending on system configuration and application. After the recorder/reproducer has been aligned, the adjustments should not be changed for the duration of the performance testing unless otherwise noted in the test procedure.

Those tests recommended during acceptance testing or after replacement of major components are indicated by a (1) and those recommended during operational readiness tests are indicated by a (2).

The point of contact for further documentation follows:

Range Commanders Council, Secretariat
Building 1510 Headquarters Avenue
White Sands Missile Range, NM 88002

Phone: 575.678.1107 (DSN 258)
E-mail: usarmy.wsmr.attec.list.rcc@mail.mil

CHAPTER 1

LONGITUDINAL FIXED HEAD RECORDING TESTS

1.1 General

This chapter defines the test procedures for longitudinal fixed-head recorder/reproducer systems. The procedures include tests of head polarity and mechanical alignment, tape speed, speed variation and timing error, direct record systems, and FM record systems.

1.2 Head Electrical Polarity and Mechanical Alignment Tests

This section describes tests to ensure maintenance of signal polarity from tape input to output of a direct record/reproduce system and tests to ensure correct alignment of record head and reproduce head azimuth.

1.3 Head Polarity Tests (1)

1.3.1 Purpose. These tests ensure that a positive-going pulse applied to the input of a direct-record amplifier produces a magnetic flux sequence on the tape, whose polarity sequence is south-north-north-south. The tests also ensure a magnetic flux sequence of south-north-north-south polarity, passed across a reproduce head, produces a positive pulse at the output of a direct reproduce amplifier.



As an alternative procedure, a tape with a known pulse polarity such as commercially prepared speed tape, may be used.

1.3.2 Test Equipment. Small rectangular bar magnet, compass, and pulse generator.

1.3.3 Test Method.

1.3.3.1 Setup. Determine the polarity of the magnet with a compass. The north-seeking pointer of the compass will be attracted to the south pole of the magnet. Mark the south pole of the bar magnet.

1.3.3.2 Conditions. None.

1.3.3.3 Procedure.

1.3.3.3.1 Using a degaussed tape of the appropriate width for the machine being tested, draw a corner of the south pole of the magnet across the width of the tape on the oxide side. Withdraw the magnet. Since the sharpness of the recorded pulse is a function of the mechanical definition of the corner of the magnet, difficulty may be encountered in obtaining an adequate output

signal. In this case, a 0.15- to 0.36-mm (0.006 to 0.0014-in) transformer lamination of soft iron or permalloy may be extended from the south pole of the bar magnet to form a narrow south pole and hence, a sharper pulse.

1.3.3.3.2 Reproduce the magnetized portion of the tape in the normal (forward) direction of tape travel. All reproduce amplifiers should give a positive-going pulse at the output when the magnetized section crosses the reproduce head (see Figure 1-1).

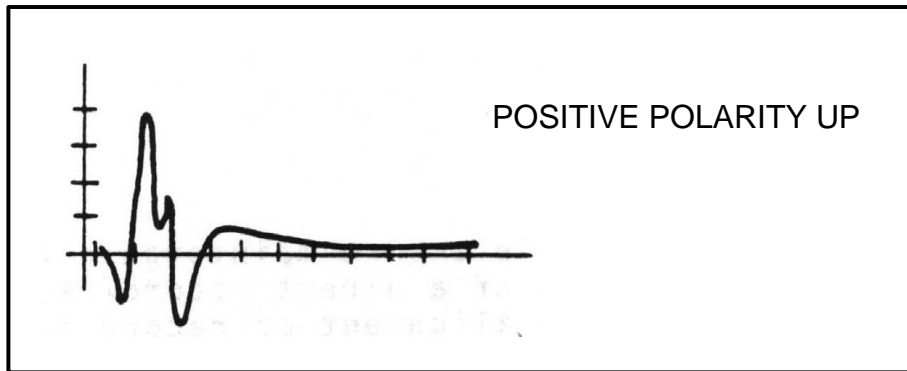

Figure 1-1. Typical waveform obtained from head polarity test (see test 1.3).

1.3.3.3.3 Connect the pulse generator to the record input. Record positive pulses (less than 50-percent duty cycle) on the tape through the record amplifiers. Reproduction of these pulses should give positive pulses at the output of the playback amplifier.

1.3.3.4 Data Reduction. Not applicable.

1.4 Record Head-Stack Azimuth Alignment (1)

1.4.1 Purpose. This test ensures that the mean gap azimuth is perpendicular to the head-mounting plate within ± 0.30 mrad (± 1 minute of arc). See Head and Head Segment Mechanical Parameters in Chapter 6 of IRIG Standard 106. For operational testing, the following quick method using the Lissajous pattern technique is recommended.

1.4.2 Test Equipment. Dual trace oscilloscope, test oscilloscope, and prerecorded commercial azimuth tape, Datatape No. 590708-1051 or Metrum No. 16815765-003 or equivalent.

Speed and Azimuth Test Tape No. 16815765, Honeywell, Denver, CO.

Azimuth Test Tape, Datatape Inc., A Kodak Company, Pasadena, CA.

1/2-inch Wideband, No. 590708-1021

1-inch Wideband, No. 590708-1051

1.4.3 Test Method.

1.4.3.1 Setup. Place the azimuth tape on the transport and select reproduce mode at desired speed.

1.4.3.2 Conditions. None.

1.4.3.3 Procedure.

1.4.3.3.1 Look at the outside even tracks (2 and 6, 14 or 28) on a dual trace oscilloscope adjust each pulse for equal amplitude and ensure proper polarity.¹

1.4.3.3.2 While triggering with one of the signals, adjust the reproduce head azimuth for a coincident display of the pulses on the dual trace oscilloscope.

1.4.3.3.3 Repeat subparagraphs 1.4.3.3.1 and 1.4.3.3.2 for odd head stack (1 and 5, 13 or 25). (Delete this subparagraph for 14-track in-line heads.)

1.4.3.3.4 Remove the azimuth tape and mount a new or degaussed tape on the transport.

1.4.3.3.5 Patch a test oscillator to tracks 2, 4, and 6 on 7-track recorders; tracks 2, 12, and 14 on 14-track recorders; or tracks 2, 26, and 28 on 28-track recorders.²

1.4.3.3.6 Connect track 2 to the vertical input of the scope and track 6, 14, or 26 to the horizontal input.

1.4.3.3.7 Record and reproduce a .008-mm (0.33-mil) wavelength sine wave (46 kHz at 381 mm/s [15 ips]) for 7-track or a 0.025-mm (1.0-mil) wavelength sine wave (15 kHz at 381 mm/s [15 ips]) for 14- and 28-track machines at standard record level.

1.4.3.3.8 Adjust the reproduce levels of the tape recorder until the track output levels are the same. The output levels of the tracks are balanced by removing the horizontal input and checking the vertical signal deflection. Reconnect the horizontal input and disconnect the vertical input. When the recorder's reproduce levels are correctly adjusted, both the horizontal and vertical will have equal deflection.

¹ IRIG Standard 106 refers to the most recent issue of IRIG 106-, Telemetry Standards.

² For 14-track in-line heads, use outside tracks 1 and 14; and tracks 1, 12, and 14 for subparagraph 1.4.3.3.5.

1.4.3.3.9 Without adjusting the reproduce heads the resultant Lissajous pattern should be an ellipse with the major axis in quadrants I and III as shown in Figure 1-2. If the major axis is in quadrants II and IV, the measurement is out of tolerance.

1.4.3.3.10 While looking at the Lissajous pattern, switch from track 6, 14, or 26 to track 4, 12, or 28. If the pattern changes quadrants, the measurement is not out of tolerance.

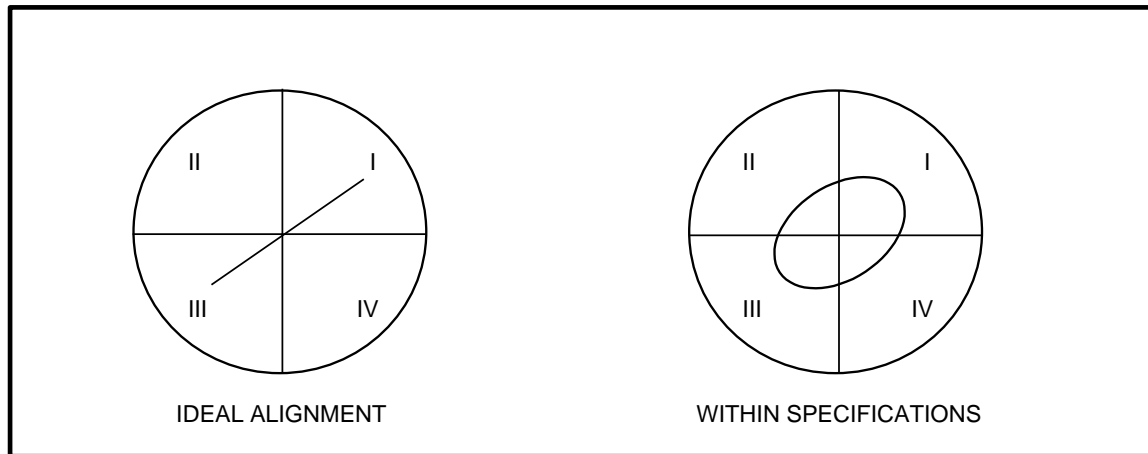

Figure 1-2. Lissajous oscilloscope patterns (see tests 1.4 and 1.5).



If these measurements are out of tolerance, be certain that the transport is not causing excessive shear stress in the tape. An unstable Lissajous pattern may be an indication of excessive interchannel time displacement error (ITDE).

1.4.3.3.11 Repeat subparagraphs 1.4.3.3.6 through 1.4.3.3.10 using tracks 1 and 5 on 7-track recorders, tracks 1 and 13 on 14-track recorders, or tracks 1 and 25 on 28-track recorders. Check for a change in quadrants using tracks 7, 11, or 27. (Delete this part for 14-track in-line heads.)

1.4.3.4 Data Reduction. If the Lissajous pattern is within tolerance, no further measurement is required. Any out-of-tolerance condition should be investigated by an optical examination to eliminate the possibility of errors caused by gap scatter and tape tolerances.

1.5 Reproduce Head-Stack Azimuth Alignment (1) and (2)

1.5.1 Purpose. The signals recorded on a magnetic tape can be used to optimize their output on any reproducer system. The reproducer system head azimuth is adjusted for optimum signal alignment match between the reproducer system and the original recorder system head segments or stacks.

1.5.2 Test Equipment. Dual trace oscilloscope and test oscillator.

1.5.3 Test Method.

1.5.3.1 Setup. Mount a new or degaussed tape on the transport.

1.5.3.2 Conditions. The Lissajous pattern technique is used as the alignment indicator.

1.5.3.3 Procedure.

1.5.3.3.1 Perform subparagraphs 1.4.3.3.5 through 1.4.3.3.10.

1.5.3.3.2 Adjust the reproduce head azimuth until a straight line in quadrants I and III are observed (see Figure 1-2).

1.5.3.3.3 While looking at the Lissajous pattern, switch from track 6, 14, or 26 to track 4, 12, or 28. If the pattern changes quadrants, readjust the azimuth³.

1.5.3.3.4 Repeat subparagraphs 1.5.3.3.1 through 1.5.3.3.3 using tracks 1 and 5 on 7-track recorders, tracks 1 and 13 on 14-track recorders, or tracks 1 and 25 on 28-track recorders. Check for a change in quadrants using tracks 7, 11, or 27.

1.5.3.4 Data Reduction. Not applicable.

1.6 Tape Speed Tests

1.6.1 General. These tests measure effective tape speed for recording or reproducing without a tape speed control signal (see subparagraph 6.8.4.1 of IRIG Standard 106, Telemetry Standards). Tape speed errors are defined as departures from the nominal tape speed occurring at frequencies below 0.5 Hz. Two test methods are specified. The first method is intended as a laboratory or factory standard and may be used for tape speed testing or for checking working standards. The second method describes a quicker test using a reference tape.

1.6.2 Tape Speed (1). The intent of the tape speed measurement test is the standardization of the "effective" rather than "absolute" tape speed. Absolute tape speed is relatively meaningless because it does not consider the operational elongation of the tape, which must be considered if a true or effective velocity measurement is to be achieved.

1.6.3 Purpose. General or Field-Use Method is recommended for those cases where a quick procedure for checking tape speed is required. Although the method for tape-speed measurement specified in Laboratory Use is an accurate method of determining tape speed, it is very time consuming for maintenance and operational testing.

³ For in-line heads, use tracks 1 and 12. Switch to tracks 1 and 14 for 1.5.3.3.4.

1.6.4 Test Equipment. For this test, commercial prerecorded tapes, Datatape No. 590706-1041 or equivalent, are used which have been recorded with saturated pulses having a pulse-to-pulse separation distance of 38.1 mm (1.5 in) to an accuracy of ± 0.01 percent under standard tension and environmental conditions. These tapes are prepared under a tape tension of 2.78 N (10 oz) ± 2 percent. Additional equipment required includes an oscilloscope, a detector, and an electronic counter as shown in Figure 1-3.

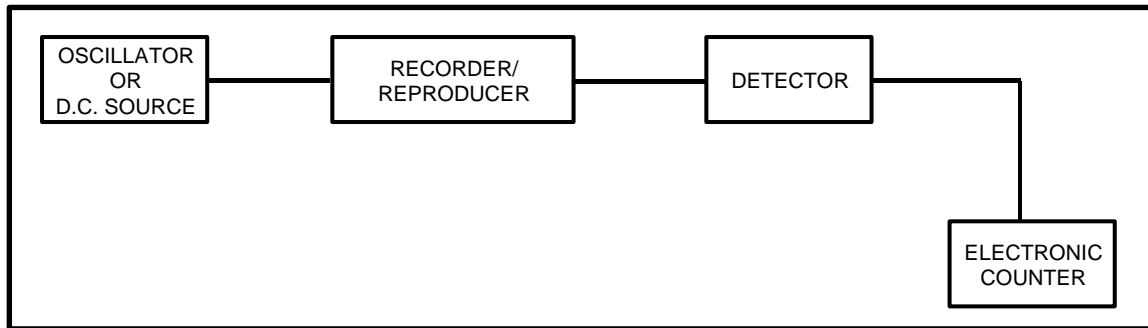

Figure 1-3. Tape speed – general or field-use method (see tests 1.6 and appendix A).

1.6.5 Test Method.

1.6.5.1 Setup. See subparagraph 1.6.5.3.

1.6.5.2 Conditions. None.

1.6.5.3 Procedure.

1.6.5.3.1 Connect a counter to the output of the recorder, disable the bias and control track signals, and short the input to the record amplifiers.

1.6.5.3.2 Place the test tape on the transport and select the reproduce mode at the selected operational speed. On an oscilloscope, verify the approximate pulse period to ensure proper operation of the counter. The spacing will be 6250 microseconds at 6096 mm/s (240 ips), 12,500 microseconds at 3048 mm/s (120 ips), 25,000 microseconds at 1524 mm/s (60 ips), 50,000 microseconds at 762 mm/s (30 ips), and 100,000 microseconds at 381 mm/s (15 ips). Measurements are to be made near the beginning, middle and end of the reel.

 **The user should select a specific reel diameter for compatibility with the data acquisition tapes. Optimum compatibility will be realized when the test tape reel diameter is the same as the diameter of the data acquisition reels. The prerecorded tapes should be of the same thickness and elastoplastic characteristics as the data acquisition tapes.**

1.6.5.3.3 The accuracy of the tape, including questions of misuse or abuse, can be checked visually by developing the pulses using a carbonyl iron dispersion and by measuring the displacement between pulses under standard tension and environmental conditions.

1.6.5.4 Data Reduction. The exact speed may be calculated by the following equation:

$$\text{Tape Speed} = \frac{38.1 \text{ mm}}{t_c} \text{ or } \frac{1.5 \text{ in.}}{t_c} \quad (1-3)$$

where

t_c = Period displayed by counter (in seconds).

1.7 Speed Variation and Timing Error Tests

This section provides procedures and describes the instrumentation used for the measurement of flutter, time base error (TBE), and interchannel time displacement error (ITDE).

1.7.1 Flutter Measurement Test (1) and (2).

1.7.1.1 Purpose. This test measures total cumulative flutter over a specified passband in instrumentation magnetic recording equipment. A recommended test method is provided.

1.7.1.2 Test Equipment. This procedure specifies use of a commercially available multifunction test instrument comprised of a signal oscillator, carrier band-pass filter, frequency discriminator, output band-pass filter, and statistical voltmeter. The equipment provides direct reading flutter measurements and is designed to read peak-to-peak amplitude and to ignore occasional random peaks provided that the value read is exceeded less than 5 percent of the time; that is, on a 2-sigma setting, the peak-to-peak flutter is within the value read 95 percent of the time. The multifunctional instrument provides components which meet the following requirements:

1.7.1.2.1 Oscillator. The oscillator must be capable of supplying a precise signal, stable in amplitude and frequency and of the desired amplitude and frequency. A sine wave is preferred for recording with bias. The residual frequency modulation must be negligible compared to the flutter amplitude anticipated.

1.7.1.2.2 Carrier Band-Pass Filter. A band-pass filter may be inserted ahead of the discriminator to limit system noise. The response of this filter must be flat within ± 3.0 dB from $f_c - (af_c + f_f)$ to $f_c + (af_c + f_f)$; where f_c is the frequency of the reference carrier, f_f is the highest frequency flutter component to be measured, and a is the fractional flutter. A roll-off of 18 dB per octave beyond band edge is suggested.

1.7.1.2.3 Frequency Discriminator. The discriminator must accept the reproduced reference carrier which has been modulated by flutter and produce an output signal proportional to the modulation. In general, 60-dB amplitude limiting must precede the frequency-sensitive portion of the discriminator to meet the dynamic range requirements of the system.

1.7.1.2.4 Flutter Band-Pass Filter. A band-pass filter follows the discriminator. Its purpose is to limit the frequency band of the flutter signal and to reject carrier frequency components. The filter shall be down no more than 3 dB at 0.5 Hz at the upper flutter frequency being measured, and should fall off at a rate of 18 dB per octave above the cutoff frequency.

1.7.1.2.5 Statistical Voltmeter. The flutter signal from the band-pass filter following the discriminator is a complex one which will, in general, be a random function, but may additionally contain discrete components. To measure this signal adequately, statistical techniques are used. A simplified block diagram is shown in Figure 1-4.

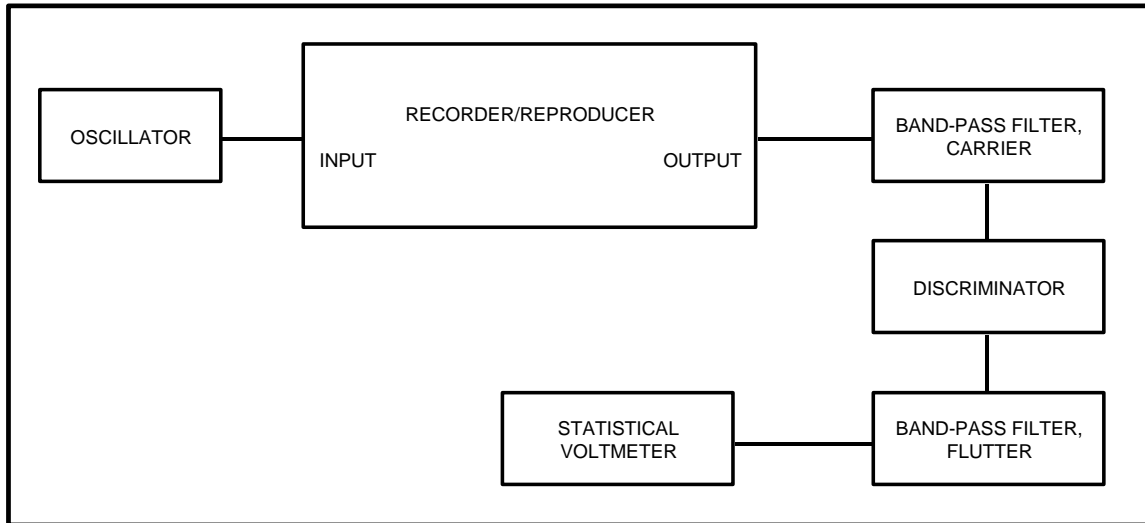

Figure 1-4. Flutter measurement (see test 1.7.1).

1.7.1.3 Test Method. Instantaneous differences between the record and reproduce tape speeds result in the frequency modulation of a recorded carrier. The basic method used to measure flutter is to determine the amount of frequency modulation (FM) caused by the record/reproduce process. Therefore, to measure flutter, a precision reference carrier is recorded and subsequently reproduced. The reproduced signal is applied to an FM discriminator whose output is a continuous electrical signal proportional to the variation between the record/reproduce speeds.

1.7.1.3.1 Procedure. This test determines the magnitude of total cumulative flutter over a specified passband. Measurements are conducted at one or more points of tape supply reel loading for the specified tape speed. Results are expressed as the percentage change of a recorded frequency during the reproduce process.

1.7.1.3.1.1 Connect the equipment as shown in Figure 1-5.

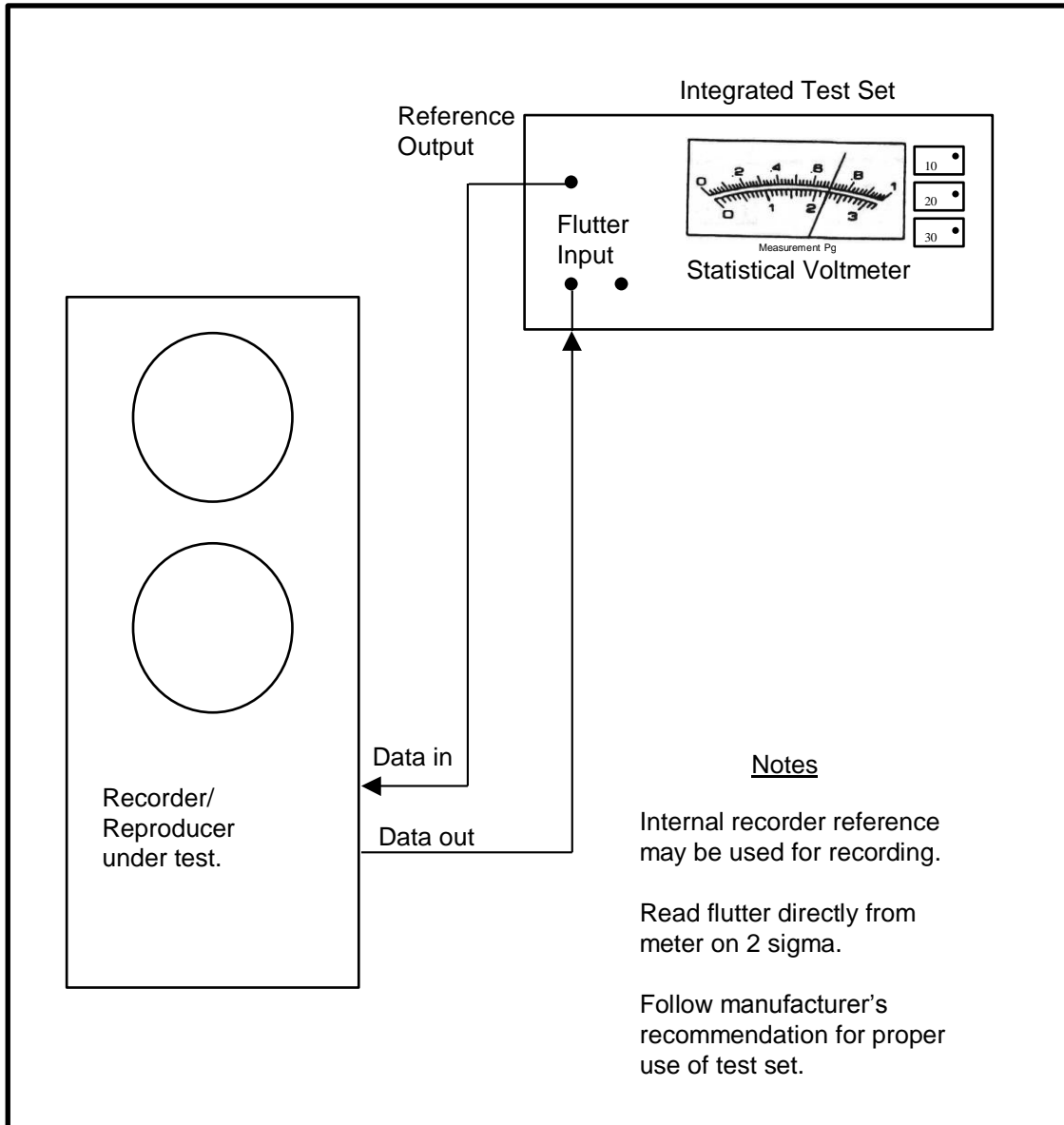

Figure 1-5. Flutter measurement using commercially available integrated test set (see test 1.7.1).

1.7.1.3.1.2 Set the oscillator to a carrier frequency of one-tenth upper band edge (UBE) for the speed being tested.

1.7.1.3.1.3 Set the flutter band-pass filter to the value shown in Table 1-1 for the speed being tested.

TABLE 1-1. FLUTTER BAND-PASS FILTER CHARACTERISTICS			
Tape Speed		Passband of the Flutter	
<u>Mm/s</u>	<u>(ips)</u>	<u>Band-Pass</u>	<u>Filter (Hz)</u>
47.6	(1 7/8)	0.5 to	313
95.2	(3 3/4)	0.5 to	625
190.5	(7 1/2)	0.5 to	1250
381	(15)	0.5 to	2500
762	(30)	0.5 to	5000
1524	(60)	0.5 to	10 000
3048	(120)	0.5 to	10 000
6069	(240)	0.5 to	10 000

1.7.1.3.1.4 Set the meter range selector to 2 sigma to take readings.

1.7.1.3.1.5 Place the degaussed tape on the machine, select the tape speed to be used, and place machine in the record mode.

1.7.1.3.1.6 Adjust the record level above the standard record level to optimize the ratio of the carrier-to-noise level. A value of approximately 6 dB above standard record level is suggested.

1.7.1.3.1.7 Record test signals on one even-numbered and one odd-numbered track. Record over full length of tape or, at a minimum, at three points: near the beginning, middle, and end of the reel.

1.7.1.3.1.8 Rewind the tape and place the machine in the reproduce mode. Conduct tests in tach and servo modes when available.

1.7.1.3.2 Data Reduction. Observe the peak-to-peak measurement at the reproduce output on a statistical voltmeter and record the results.

 <p>NOTE</p>	<p>Readings in the tach mode may be taken while simultaneously recording and reproducing but should be verified in the reproduce mode if near specification limits.</p>
--	--

1.7.2 Time Base Error Test (1) and (2).

1.7.2.1 Purpose. This test measures the time base error (TBE) of events recorded on a single track.

1.7.2.2 Test Equipment. Two procedures are described in this section. One procedure uses a commercially available test instrument, while the other procedure uses a signal generator and an oscilloscope. The multifunction test instrument includes an oscillator, carrier band-pass filter, frequency discriminator, output band-pass filter, and statistical voltmeter. The equipment provides direct reading measurements and is designed to read peak-to-peak amplitude and to ignore occasional random peaks provided the value read is exceeded less than 5 percent of the time; that is, on a 2-sigma setting, the peak-to-peak measurand (TBE) is within the value read 95 percent of the time. If the oscilloscope method is used, the oscilloscope must be a dual channel model with a bandwidth of at least 100 MHz to provide sufficient resolution.

1.7.2.3 Test Method. To measure TBE, the internal servo reference frequency is recorded and subsequently reproduced. The time base of the reproduced signal is then compared with that of the servo reference frequency with the recorder in the servo mode.

1.7.2.3.1 Procedure. Measurements are conducted at one or more points of the tape supply reel loading for the specified tape speed. Results are expressed as the number of microseconds difference in time base of the reproduced signal compared to the servo reference frequency.

1.7.2.3.1.1 Connect the equipment as shown in Figure 1-6 or 1-7.

1.7.2.3.1.2 If applicable, set the integrated test set to 2 sigma to take readings.

1.7.2.3.1.3 Place the degaussed tape on the machine and select the tape speed to be used.

1.7.2.3.1.4 Set up equipment and record test signal in accordance with manufacturer's instruction manual.

1.7.2.3.1.5 Depending upon the operational speed selected, record a sufficient length of tape at the beginning, middle, and end of the reel to provide adequate time for tape speed servo acquisition and lockup before performance measurements.

1.7.2.3.1.6 Rewind the recorded tape and place the recorder/reproducer in the reproduce mode. Select the transport tape servo system for the tape mode.

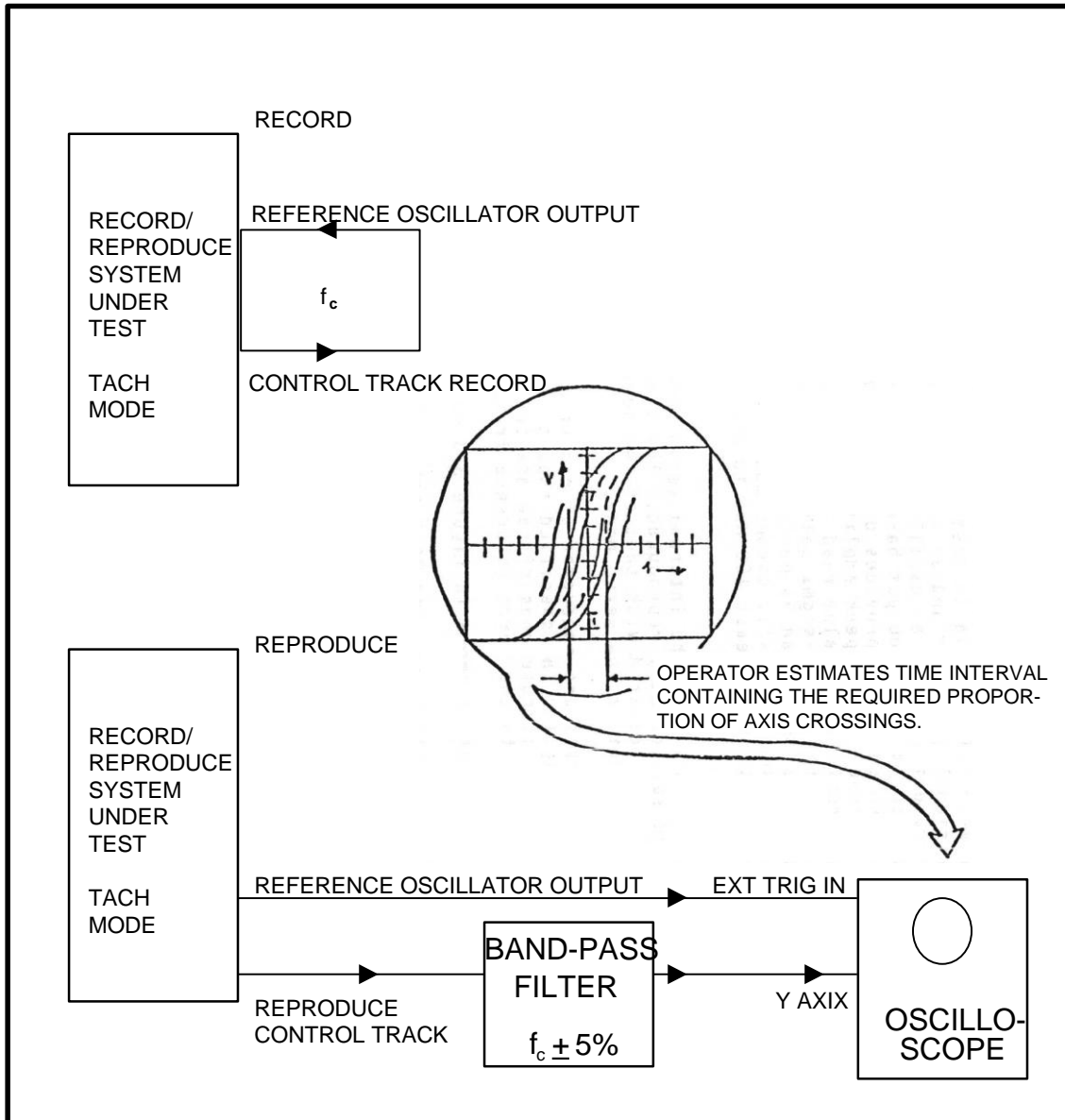

Figure 1-6. Time base error measurement (see test 1.7.2).

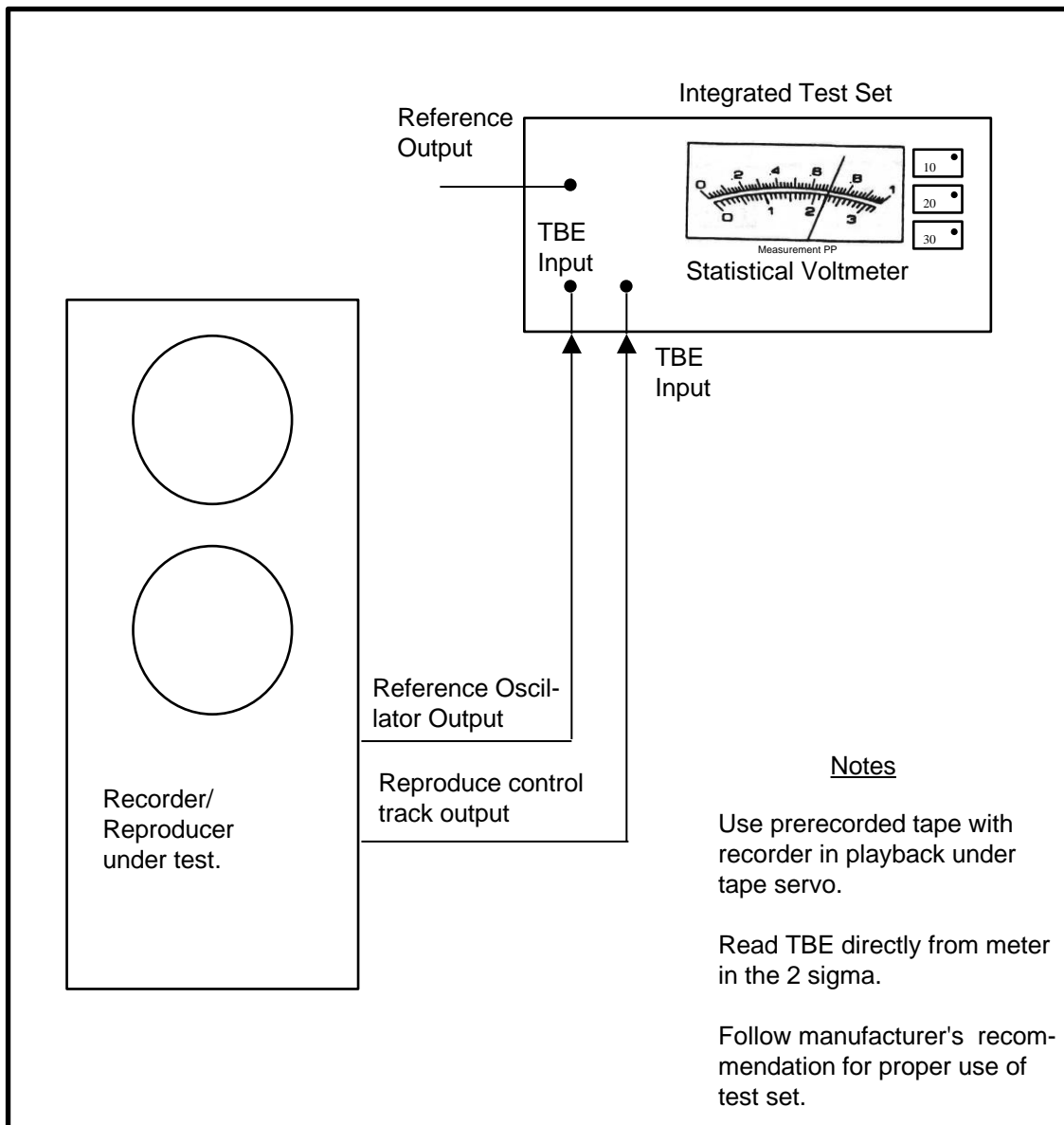

Figure 1-7. Time base error measurement using integrated commercially available test set (see test 1.7.2).

1.7.2.3.1.7 If the integrated test set is used, follow manufacturer's instruction for determining the TBE. If an oscilloscope is to be used, adjust the oscilloscope time base and trigger to display a single leading edge with the TBE component occupying a minimum of 1 cm (horizontal).

1.7.2.3.1.8 When using an oscilloscope, set the vertical gain so that the upper and lower portions of the waveform touch the outer graticule lines. Adjust the scope intensity to a level which prevents trace blooming, but still displays individual transient excursions. Optional band-pass filtering of the reproduced waveform serves to remove all noise components except those existing within the narrow band.

1.7.2.3.2 Data Reduction. Observe or photograph the CRT display over 10-second sample periods at the beginning, middle, and end of the reel. Convert the TBE displayed on the oscilloscope to units of time based upon the horizontal width of the solid portion of the display. Ignore crossovers occurring not more than 5 percent of the time. If integrated test set is used, observe the peak-to-peak measurement on statistical voltmeter. Record the results.

1.7.3 Interchannel Time Displacement Error Test (1) and (2).

1.7.3.1 Purpose. This test measures the Interchannel Time Displacement Error (ITDE) (dynamic skew) of simultaneous events recorded on separate tracks.

1.7.3.2 Test Equipment. Two procedures are described in this section. One procedure uses a commercially available test instrument, while the other procedure uses a signal generator and an oscilloscope. The multifunction test instrument includes an oscillator, carrier band-pass filter, frequency discriminator, output band-pass filter, and statistical voltmeter. The equipment provides direct reading measurements and is designed to read peak-to-peak amplitude and to ignore occasional random peaks provided the value read is exceeded less than 5 percent of the time; that is, on a 2-sigma setting, the peak-to-peak measurand (ITDE) is within the value read 95 percent of the time. If the oscilloscope method is used, the oscilloscope must be a dual channel model with a bandwidth of at least 100 MHz to provide sufficient resolution.

1.7.3.3 Test Method. To measure ITDE, an oscillator frequency is recorded on two tracks and subsequently reproduced. The time base of the reproduced signal from the two tracks is then compared.

1.7.3.3.1 Procedure. Measurements are conducted at one or more points of tape supply reel loading for the specified tape speed. Results are expressed as the number of microseconds difference between the reproduced signals.

1.7.3.3.1.1 Connect the equipment as shown in Figure 1-8 or 1-9.

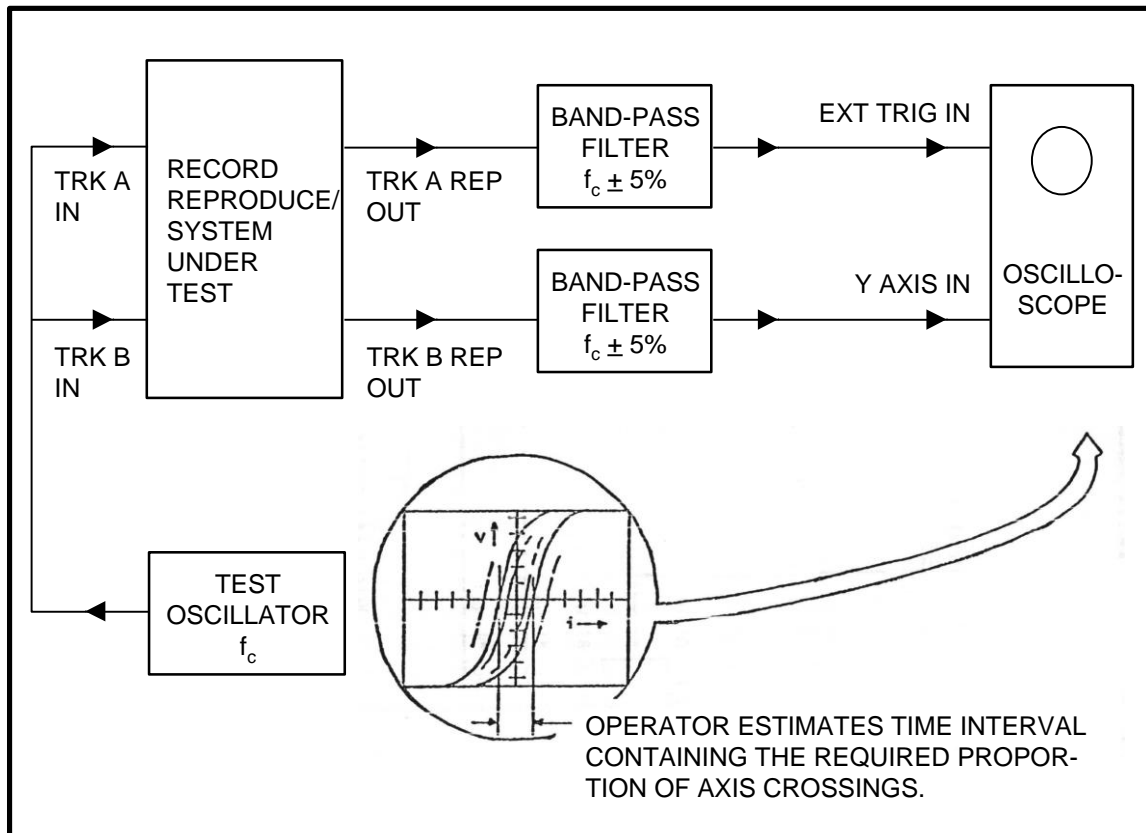

Figure 1-8. Interchannel time displacement error

1.7.3.3.1.2 If a test set is used, set the meter range selector to 2 sigma to take readings.

1.7.3.3.1.3 Place the degaussed tape on the machine and select the tape speed to be used.

1.7.3.3.1.4 Record the test oscillator signal on two outside head tracks within the same stack, for example, 1 and 13 or 2 and 14, using the standard record amplifier input. At high transport speeds, the entire reel of tape may be recorded. With lower speeds, a recording of one to two minutes at the beginning, middle, and end of the reel is satisfactory.

1.7.3.3.1.5 Rewind the recorded tape and place the recorder/reproducer in the reproduce mode without servo. Adjust oscilloscope time base and trigger to display a single leading edge using the minimum delay necessary to get the required display with the ITDE component occupying a minimum of 1 cm (horizontal). If the integrated test set is used, connect the test set as per manufacturer's instruction, place metering circuits on 2 sigma and read ITDE directly from meter.

1.7.3.3.1.6 When using an oscilloscope, set the vertical gain so that the upper and lower portions of the waveform touch the outer graticule lines. Adjust the scope intensity to a level that prevents trace blooming, but still displays individual transient excursions. Optional band-

pass filtering of the reproduced waveform serves to remove all noise components except those existing within this narrow band.

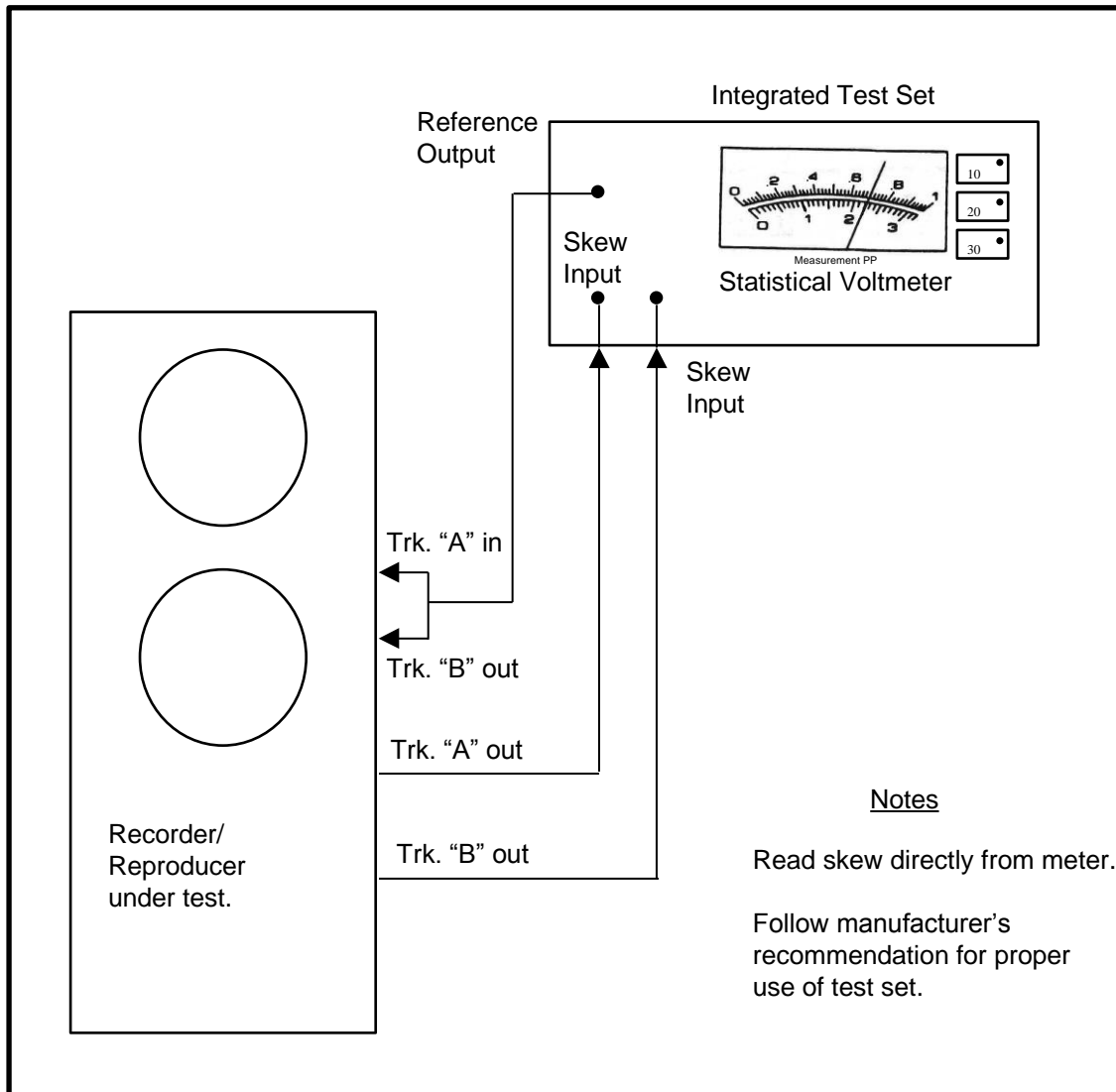

Figure 1-9. Interchannel time displacement error (skew) measurement using integrated commercially available test set (see test 1.7.3)

1.7.3.3.2 Data Reduction. Observe or photograph the CRT display over 10-second sample periods over the entire length of tape or, at a minimum, at the beginning, middle, and end of the reel. Convert the ITDE displayed on the oscilloscope to units of time based upon the horizontal width of the solid portion of the display. Ignore crossovers occurring not more than 5 percent of the time. If integrated test set is used, observe the peak-to-peak measurement on statistical voltmeter. Record the results.

1.8 Direct Record System Tests

1.8.1 General. This section defines a series of test procedures to characterize the performance of direct record systems. Not all of the procedures may be required for a series of tests, but for those tests used, the bias and record level adjustments may be performed only once during a sequence of tests. Bias and record level settings are normally established at the highest operating tape speed (refer to manufacturer's instructions). The procedures defined include tests for bias and record level, frequency response, signal-to-noise ratio (SNR), intermodulation distortion (IMD), cross talk, bias leakage, second harmonic distortion, multispeed record level, record transfer characteristics, and group delay variation and transient response measurements.

1.8.2 Bias, Record Level and Second Harmonic Distortion Tests (1) and (2).

1.8.2.1 Purpose. These tests establish bias and record level settings as specified in Record and Reproduce Parameters, Table 6-1, Chapter 6 of IRIG Standard 106, and measure second harmonic distortion.

1.8.2.2 Test Equipment.

1.8.2.2.1 Oscillator. Sinusoidal oscillator or signal generator must meet impedance and level requirements of the recorder/reproducer under test. Noise, distortion, and spurious components should be below 0.2 percent over the frequency range under test.

1.8.2.2.2 Voltmeter. True root mean square (rms) reading voltmeter calibrated to an accuracy of ± 0.5 dB over frequency range under test.

1.8.2.2.3 Wave Analyzer (Frequency Selective Voltmeter). Calibrated to an accuracy of ± 0.5 dB with a dynamic range of at least 60 dB.

1.8.2.3 Test Method.

1.8.2.3.1 Setup. Connect the test equipment, instruments, and loads as shown in Figure 1-10. The optional band-pass filter is not used.

1.8.2.3.2 Conditions. Refer to the manufacturer's instructions for details pertaining to adjustments and to procedural steps.

1.8.2.3.3 Procedure.

1.8.2.3.3.1 With the signal source set to the record-bias set frequency and input level set 5 to 6 dB below standard record level, record and simultaneously reproduce a tape and adjust the bias to the proper overbias level indicated in Table 6-1 of IRIG 106.

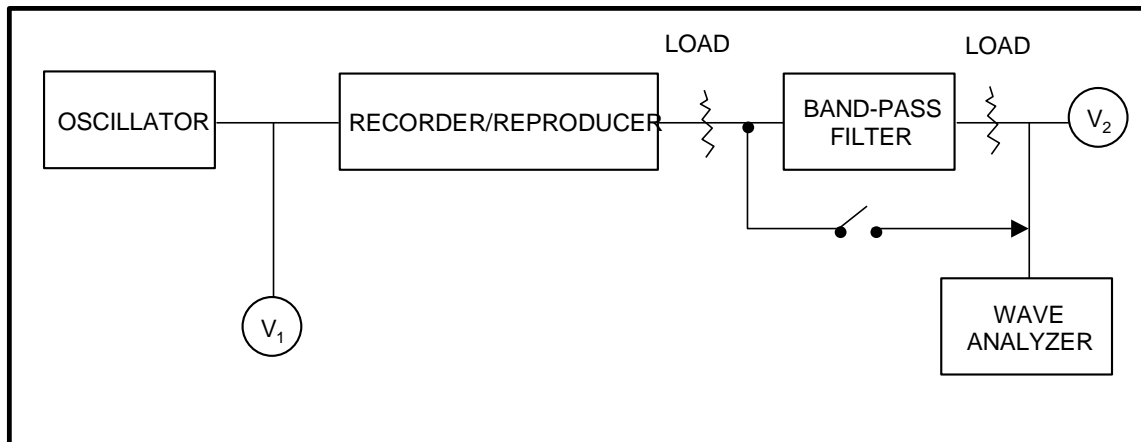

Figure 1-10. Frequency response and signal-to-noise ration (see tests 1.8.2, 1.8.3, and 1.8.4).

1.8.2.3.3.2 Before completing this step, be sure the selected level is below possible tape saturation at all three frequencies: fundamental frequency, second, and third harmonics. Record and reproduce sine wave signals of frequencies equal to the record level set frequency. Then at two and three times the record level, set frequency at the input level used to establish standard record level. Check the three reproduced output levels and compensate for any differences by equalizer adjustment or by mathematically adjusting subsequent computations to within ± 1 dB of the record level set frequency output.

1.8.2.3.3.3 To establish the standard record level, set the signal source frequency to the record level set frequency and adjust the record amplifier until 1 percent (-40dB) third harmonic distortion is indicated by the wave or spectrum analyzer.

1.8.2.3.3.4 Measure and log the second harmonic distortion level indicated by the wave or spectrum analyzer.

1.8.2.3.4 Data Reduction. Not applicable.

1.8.3 Frequency Response (Direct Recording) Test (1) and (2).

1.8.3.1 Purpose. This test measures amplitude variations within the passband of the recorder/reproducer system.

1.8.3.2 Test Equipment. Refer to equipment listed in subparagraph 1.8.2.2 and Figure 1-10.

1.8.3.3 Test Method.

1.8.3.3.1 Setup. Connect the test equipment, instruments, and loads as indicated in Figure 1-10.

1.8.3.3.2 Conditions. No external band-pass filter is used in this test.

1.8.3.3.3 Procedure.

1.8.3.3.3.1 Perform the initial adjustment of bias and record level as described in subparagraph 1.8.2.4

1.8.3.3.3.2 With the signal source set to produce standard record level at the record level set frequency, observe the actual input level (V_1). This voltage shall be considered the 0-dB input reference.

1.8.3.3.3.3 Record and reproduce a tape and observe the reproduce output level (V_2).

1.8.3.3.3.4 Record and reproduce a tape, varying the input frequency over the specified frequency band while maintaining input (V_1) at the reference level. (See Record and Reproduce Parameters, Table 6-1, Chapter 6 of IRIG Standard 106.)

1.8.3.3.4 Data Reduction. Observe and log (in dB) the maximum and minimum excursions of the reproduce output level (V_2) with respect to the reading obtained in subparagraph 1.8.3.3.3.3.

1.8.4 Signal-to-Noise Ratio Tests. Passbands obtained in test 1.8.3 and this test may not be identical and should not be directly compared. Filter characteristics should be known or verified before running the SNR test.

1.8.4.1 Purpose. This test determines the ratio of standard record level rms signal plus noise output voltage to the zero modulation rms noise and spurious signal output voltage (the noise arising when reproducing a tape recorded with no signal into the record head, but with bias energized). Measurements shall be conducted while simultaneously recording and reproducing with bias.

1.8.4.2 Test Equipment. Refer to Figure 1-10.

1.8.4.3 Test Method.

1.8.4.3.1 Wide Band SNR (1) and (2).

1.8.4.3.1.1 Setup. Connect the test equipment, instruments, and loads as shown in Figure 1-10 using a band-pass filter like that listed in subparagraph 1.8.2.2.

1.8.4.3.1.2 Conditions. None.

1.8.4.3.1.3 Procedure.

1.8.4.3.1.3.1 Perform the initial adjustment of the bias and record level as described in subparagraph 1.8.2.4 and in the manufacturer's instructions.

1.8.4.3.1.3.2 With the signal source set to produce standard record level at the record level set frequency, observe, and log the output level (V_2).

1.8.4.3.1.3.3 Remove the input signal and substitute a short circuit.

1.8.4.3.1.3.4 Observe and log the output level (V_2). Use a true rms voltmeter.

1.8.4.3.1.4 Data Reduction. Determine the difference in dB between the reading obtained in subparagraph 1.8.4.4.2 and the reading obtained in subparagraph 1.8.4.3.1.3.3 and 1.8.4.3.1.3.4.

1.8.4.4 Slot (1).

1.8.4.4.1 Record and reproduce at the highest available recorder speed a one-tenth UBE sine-wave signal on track 1 at standard record level.

1.8.4.4.2 Set output to 0 dBm and monitor on spectrum analyzer. The spectrum analyzer should have a 1 kHz slot bandwidth and the sweep set from 5 kHz to UBE of the selected speed.

1.8.4.4.3 Remove the signal and simultaneously record and reproduce a section of noise on the tape.

1.8.4.4.4 Measure and log the highest noise level.

1.8.4.4.5 Repeat for other tracks.

1.8.4.4.6 Repeat at next lower speed.

1.8.4.5 Data Reduction. Not applicable.

1.8.5 Intermodulation Distortion Test (1). Also refer to the, Noise Power Ratio (NPR) test in volume IV and the Intermodulation Distortion (IMD) tests in volume II of this series.

1.8.5.1 Purpose. This test measures IMD components to give an indication of channel linearity.

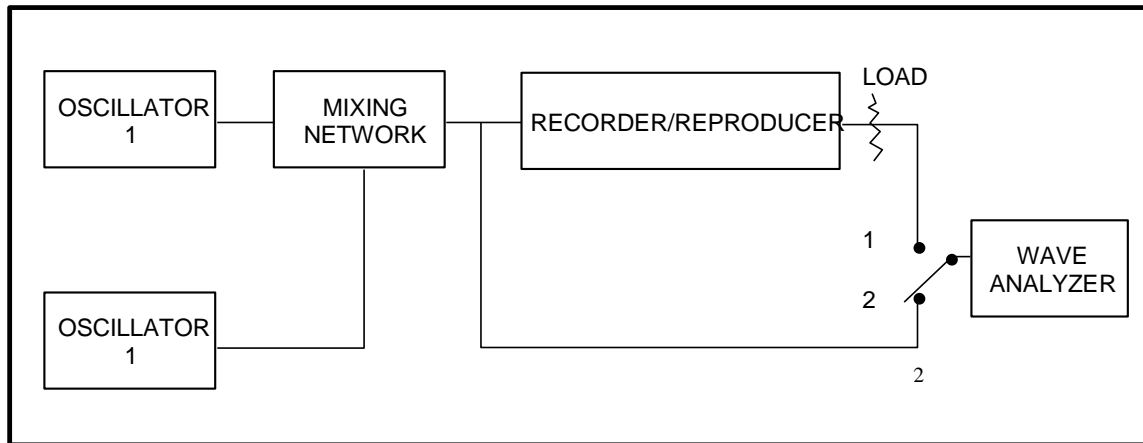

Figure 1-11. Intermodulation distortion test (see tests 4.4, 4.5, 4.6, 4.7, and 4.8).

1.8.5.2 Test Equipment. See Figure 1-11 for configuration.

1.8.5.3 Procedure.

1.8.5.3.1 Determine the input voltage required to give the standard record level with the wave or spectrum analyzer. Disconnect second oscillator and replace with equivalent generator impedance.

1.8.5.3.2 Set oscillators 1 and 2 to give the input voltages for f_1 and f_2 equal to one-half the voltage determined in subparagraph 1.8.5.3. Test frequencies recommended for general purpose testing are $f_1 = 0.45$ and $f_2 = 0.55$ of the UBE frequency. Other frequencies may be substituted as necessary. Components outside the passband may be logged, if required.

1.8.5.3.3 Check the harmonic and IMD component frequency input voltages with the wave analyzer (switch position 1 in Figure 1-11) and determine that all the components listed in Table 1-2 are at least 10 dB lower than the equipment performance specification.

1.8.5.4 Data Reduction. Record and reproduce a tape. Observe and log (in dB) the IMD component frequency output voltages (switch position in Figure 1-11) as listed in Table 1-2 relative to the standard record level output. Additional component frequencies may be present in the passband if other frequencies are used for f_1 and f_2 .

TABLE 1-2. IMD TEST FREQUENCIES

<u>Component</u>	<u>Frequency*</u>
f_1	0.45
f_2	0.55
f_2-f_1	0.10
$2f_1-f_2$	0.35
$2f_2-f_1$	0.65
$2f_1$	0.90
f_1+f_2	1.00

*The second column gives test frequencies for general use as a fraction of the UBE ($f=1.0$).

1.8.6 Crosstalk Test (1).

1.8.6.1 Purpose. This test measures the cross-talk signal level from one channel to all other channels.

1.8.6.2 Test Equipment. Refer to Figure 1-11; however, delete oscillator 2, the mixing network and the bypass signal line to the wave analyzer.

1.8.6.3 Test Method.

1.8.6.3.1 Setup. Connect the test equipment as indicated in Figure 1-11 and subparagraph 1.8.6.2.

1.8.6.3.2 Conditions. None.

1.8.6.3.3 Procedure.

1.8.6.3.3.1 Record at the standard record level and reproduce at the highest available tape speed on a 5 kHz sine wave on each track. Set the output of each track to 0 dB.

1.8.6.3.3.2 Record a 5 kHz sine wave at standard record level on track 1 with the inputs to all other tracks shorted.

1.8.6.3.3.3 Rewind and reproduce a signal on track 1 while logging output of other tracks as measured on the wave or spectrum analyzer.

1.8.6.3.3.4 Repeat using other tracks as references.

1.8.6.3.3.5 Repeat using UBE record frequency at the highest available tape speed.

1.8.6.3.3.6 Change to the next lowest tape speed and sine-wave frequency to 2 kHz. Repeat subparagraphs 1.8.6.4.1 through 1.8.6.4.5.

1.8.6.3.4 Data Reduction. Not applicable.

1.8.7 Bias Leakage Test (1).

1.8.7.1 Purpose. This test determines the level of bias leakage during the record mode.

1.8.7.2 Test Equipment. Refer to Figure 1-11; however, delete oscillator 2, the mixing network and the bypass signal line to the wave analyzer.

1.8.7.3 Test Method.

1.8.7.3.1 Setup. Connect the test equipment as shown in Figure 1-11 with the modifications detailed in subparagraph 1.8.7.2.

1.8.7.3.2 Conditions. None.

1.8.7.3.3 Procedure.

1.8.7.3.3.1 Load a bulk-erased tape of the appropriate type into the recorder.

1.8.7.3.3.2 At the highest available tape speed, record and reproduce the record level set frequency on at least one odd-numbered and one even-numbered tape track. Terminate both input and output in rated impedances and adjust input and output levels to 1 V rms.

1.8.7.3.3.3 Reduce the input level to zero while continuing to record only the bias signal. With a wave analyzer, measure the bias leakage voltage at the following circuit points:

- Odd track output signal line, high side to low side.
- Even track output signal line, high side to low side.
- Odd track output signal line, high side to a convenient front panel chassis ground.

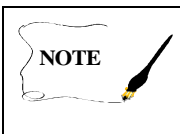
	Chassis ground must be properly connected to the local instrumentation ground during the test.
---	---

- Even track output signal line, high side to a convenient front panel chassis ground.
- Odd track output signal line, low side to chassis ground.
- Even track output signal line, low side to chassis ground.

1.8.7.3.4 Data Reduction. Not applicable.

1.8.8 Multispeed Record Level Test (1).

1.8.8.1 Purpose. This test determines the change in the standard record level setting (third harmonic distortion level) as a function of tape speed.

1.8.8.2 Test Equipment. Signal oscillator and wave analyzer.

1.8.8.3 Test Method.

1.8.8.3.1 Setup. Connect the test equipment as shown in Figure 1-11; however, delete oscillator 2, the mixing network and bypass signal line. Connect the reproduced signal to the wave analyzer as shown.

1.8.8.3.2 Conditions. None.

1.8.8.3.3 Procedure.

1.8.8.3.3.1 Load a bulk-erased tape of the type recommended onto the recorder.

1.8.8.3.3.2 At the highest recorder speed, record a one-tenth UBE 1 V rms signal at a standard record level (1 percent third harmonic distortion). Adjust the reproduce level for 1 V rms.

1.8.8.3.3.3 Reduce speed one setting.

1.8.8.3.3.4 Record a one-tenth UBE 1 V rms signal. Do not adjust the record level. Be sure that the reproduced output is 1 V rms and adjust if necessary.

1.8.8.3.3.5 Measure the record level. The third harmonic distortion must be within the range specified by the user (0.7 to 1.3 percent is suggested).

1.8.8.3.3.6 Repeat subparagraphs 1.8.8.3.3.3 through 1.8.8.3.3.5 until the lowest required speed has been tested.

1.8.8.3.4 Data Reduction. Not applicable.

1.8.9 Record Transfer Characteristic Test (1).

1.8.9.1 Purpose. This test determines that record head losses at high frequencies are compensated by the record amplifier. Low frequency signals are recorded and reproduced at one-eighth the highest tape speed on the machine. High frequency signals are then recorded at the highest tape speed on the machine and reproduced at the lower tape speed. Frequencies recorded in the two tests are chosen to be at the same wave length on the tape. The intent of the procedure is to eliminate the variation in response of the tape, the frequency losses in the reproduce system, and azimuth misalignments (see Table 6-1, IRIG Standard 106).

1.8.9.2 Test Equipment. Signal oscillator and voltmeter.

1.8.9.3 Test Method.

1.8.9.3.1 Setup. Connect the test equipment as shown in Figure 1-11; however, delete band-pass filter bypass, band-pass filter, load 2, and wave or spectrum analyzer. Connect the reproduced output to the voltmeter.

1.8.9.3.2 Conditions. None.

1.8.9.3.3 Procedure.

1.8.9.3.3.1 Load a bulk-erased tape of the appropriate type onto the recorder.

1.8.9.3.3.2 Record and reproduce at one-eighth the highest tape speed of the machine frequencies of 0.02, 0.1, 0.5, 0.8, and 1.0 times the maximum specified bandwidth for that speed. The input is set to the standard record level. On recorder/reproducers with azimuth adjustable reproduce heads, adjust the azimuth for the maximum output of the UBE frequency. Note the absolute output level of all the frequencies.

1.8.9.3.3.3 Rewind and erase the tape. Frequencies eight times as high as those used in subparagraph 1.8.9.3.3.2 should be recorded at the highest speed of the machine. Take reasonable care to record the same wavelength signals at the same place and in the same direction on the tape as in subparagraph 1.8.9.3.3.2. Each frequency should be recorded approximately one-eighth as long as in subparagraph 1.8.9.3.3.2.

1.8.9.3.3.4 Reproduce the tape recorded in subparagraph 1.8.9.3.3.3 at one-eighth the highest tape speed of the machine. On machines with azimuth adjustable reproduce heads, adjust azimuth for maximum UBE. Note the absolute output level of all frequencies.

1.8.9.3.4 Data Reduction. The deviation from ideal recording is defined as the difference between the response curves obtained in subparagraphs 1.8.9.3.3.2 and 1.8.9.3.3.4 when the curves are mathematically adjusted to have the 0.02 frequency point in common.

1.8.10 Eye Pattern (1).

1.8.10.1 Purpose. The eye pattern test is useful for determining the distortion of a pulse code modulation (PCM) signal. The distortion can result in jitter in the time crossings and reduction in the signal amplitude. The distortion is typically caused by a combination of non-constant group delay and filtering.

1.8.10.2 Test Equipment. Pseudo-noise (PN) generator, oscilloscope, bit synchronizer, plotter, or oscilloscope camera (optional).

1.8.10.3 Test Method.

1.8.10.3.1 Setup. Connect test equipment as shown in Figure 1-12.

1.8.10.3.2 Conditions. This test may be performed during the record tape pass or during a separate tape pass. All cables must be terminated in the proper impedance.

1.8.10.3.3 Procedure. Set the bit rate and code of the PN generator and bit synchronizer to the desired values. With wideband recording, the maximum recommended packing densities are 25 kb/in for RNRZ-L and 15 kb/in for Bi-Phase-L. The maximum recommended packing densities for double density recording are 50 kb/in for RNRZ-L and 30 kb/in for Bi-Phase-L. Set the oscilloscope to trigger on the clock signal from the bit synchronizer. Start the recorder and adjust the oscilloscope amplitude and time base controls to produce a display similar to those in Figures 1-13, 1-14, 1-15, and 1-16. The signals shown in Figures 1-13 and 1-14 had bit error rates of essentially zero. The signals shown in Figures 1-15 and 1-16 had approximately 1 error per 100,000 bits.

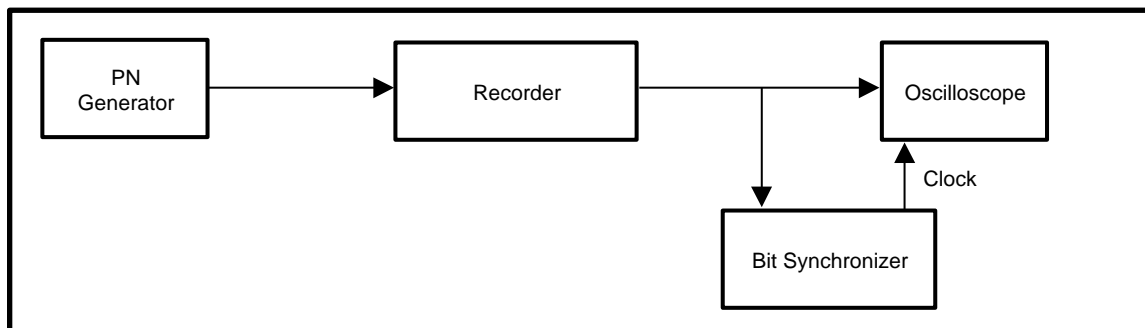

Figure 1-12. Eye pattern test setup.

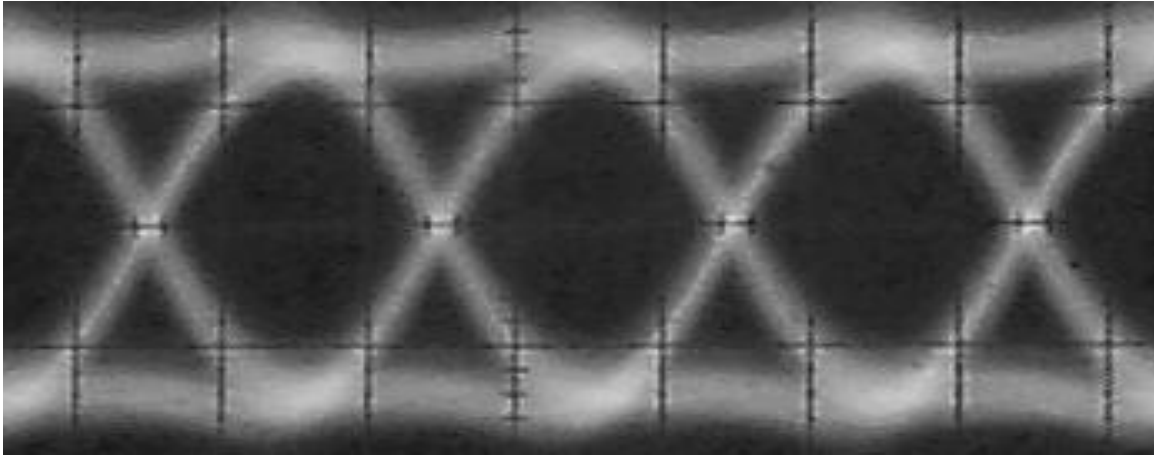

Figure 1-13. Good NRZ eye pattern

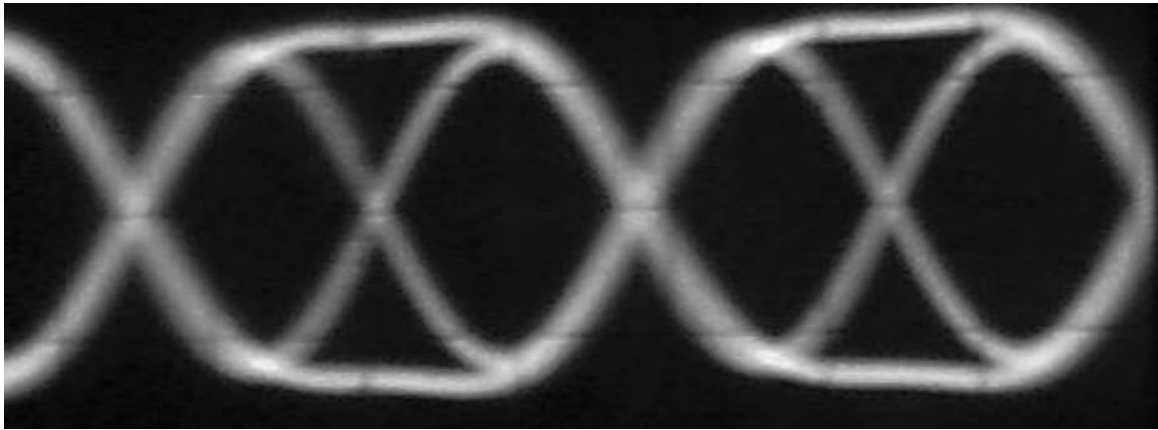

Figure 1-14. Good bi-phase eye pattern.

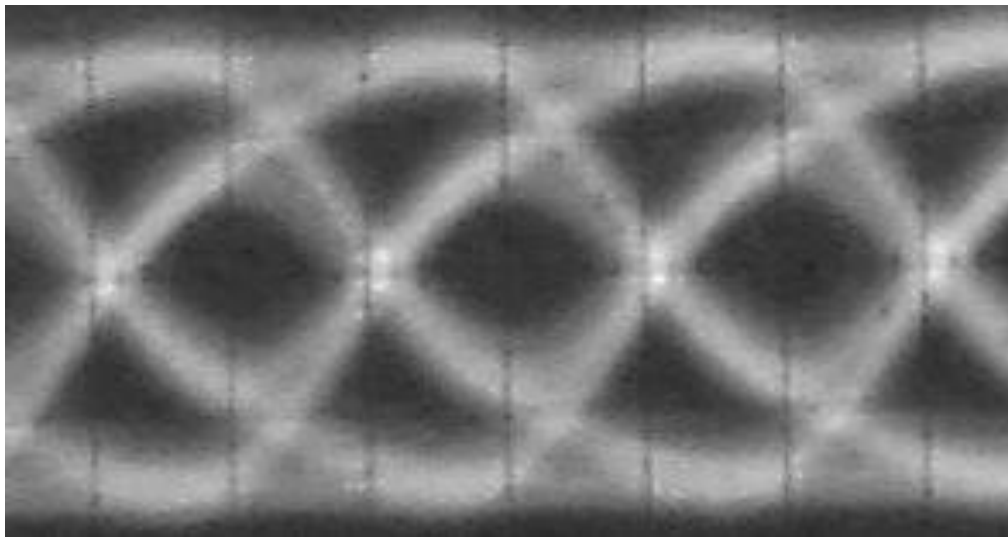

Figure 1-15. Poor NRZ eye pattern.

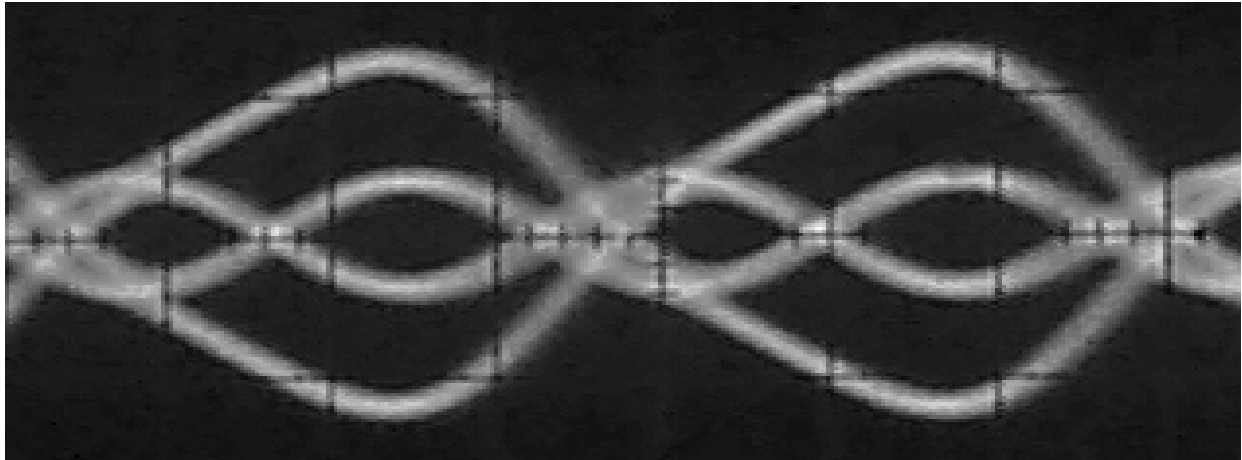

Figure 1-16. Poor bi-phase eye pattern.

Measure the peak-to-peak time jitter, nominal peak-to-peak amplitude, and peak-to-peak amplitude at the center of the eye opening. Record these values on a Data Sheet 1-8. If the appropriate equipment is available, plot or photograph the oscilloscope display and attach to the Data Sheet.

1.8.10.3.4 Data Reduction. Multiply the time jitter by the bit rate and multiply this result by 100 to get the peak-to-peak jitter as a percentage of the bit period. Divide the minimum eye opening by the nominal eye opening and multiply by 100 to get the percentage eye opening. For example, in Figure 1-14 the peak-to-peak jitter is approximately 12 percent of a bit period and the eye is approximately 80 percent open. The corresponding values for Figure 1-16 are 26 percent and 17 percent, respectively.

DATA SHEET 1-1 DIRECT RECORD SYSTEM TESTS

Test: 1.8.10 Eye Pattern

Manufacturer _____ Model _____ Serial No.

Test Personnel _____ Date

Tape speed: _____ inches per second

Recording code: _____

Bit Rate: _____ Megabits per second

Zero crossing time jitter: _____ microseconds (peak-to-peak)

Time jitter x bit rate x 100: _____ %

Nominal amplitude: _____ volts (peak-to-peak)

Minimum eye opening: _____ volts (peak-to-peak)

100 x minimum/nominal: _____ %

(Attach photograph or plot if available)

1.9 FM System Tests

1.9.1 General. All FM systems tests except drift and dc linearity are run through the tape. Allow the equipment to warm up for the specified length of time. In the absence of a warm-up specification, the warm-up time is in accordance with the manufacturer's recommendation. All percentages are referred to full positive to negative deviation as 100 percent. This procedure is intended to test those systems listed in Dimensions - Recorded Tape Format, 14 Tracks In-Line on 25.4 mm (lin.) Widetape, Table 6-4, Chapter 6 of IRIG Standard 106. The FM tests in this chapter include deviation, center frequency, and polarity; frequency response; SNR; distortion; spurious components; dc linearity; dc drift at center frequency; multispeed reproduce transfer levels; and group delay variation and transient response.

1.9.2 Deviation, Center Frequency And Polarity Tests (1) and (2).

1.9.2.1 Purpose. These tests ensure that the center frequency is correctly set, that a maximum input signal level produces full deviation in carrier frequency, and that a corresponding output voltage (of known polarity) is present at the output of the reproduce amplifiers.

1.9.2.2 Test Equipment. Frequency counter, signal source (dc), volt-meter (dc), and oscilloscope.

1.9.2.3 Test Method.

1.9.2.3.1 Setup. Connect the test equipment as shown in Figure 1-17.

1.9.2.3.2 Conditions. None.

1.9.2.3.3 Procedure. Check the center frequency by shorting the input of the amplifier and monitoring the carrier frequency with an electronic counter. Adjust the center frequency to conform within 1.0 percent of the values specified in Table 6-8, FM Record Parameters, Chapter 6, IRIG Standard 106. The deviation and polarity shall be checked as follows:

1.9.2.3.3.1 Apply the maximum positive dc input signal level and verify a full positive deviation in carrier frequency and a corresponding positive output voltage from the reproduce amplifiers.

1.9.2.3.3.2 Apply the negative peak dc input signal and verify a full negative deviation in carrier frequency and a corresponding negative output voltage from the reproduce amplifier.

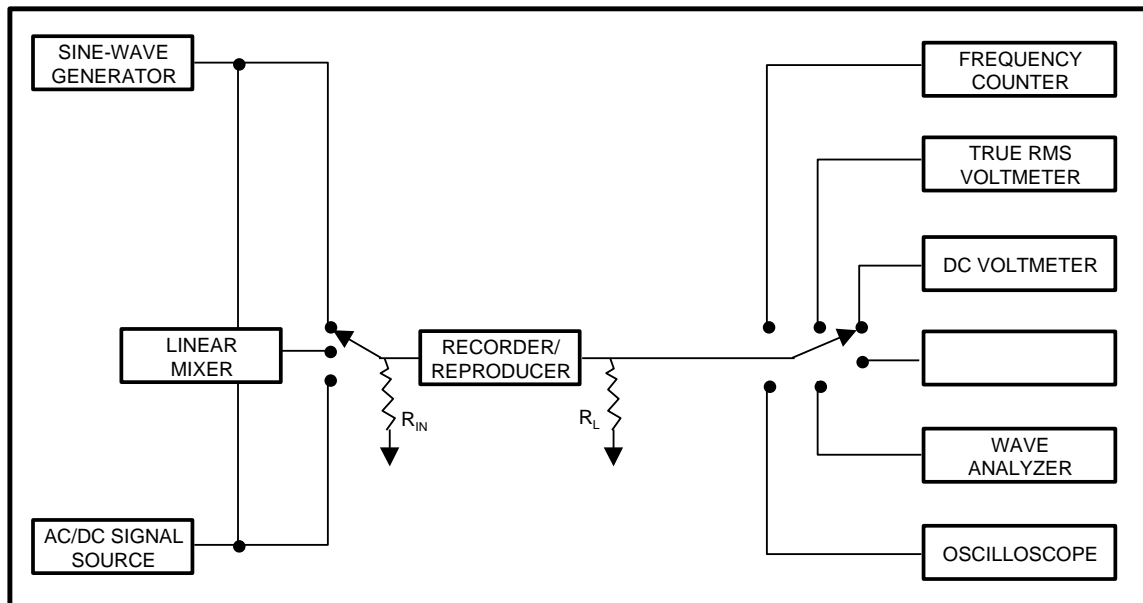



Figure 1-17. FM system test equipment setup (see tests 1.7.2, 1.9.3, 1.9.4, 1.9.5, 1.9.6, 1.9.7, and 1.9.8).

NOTE  **Diagram includes equipment required for all FM tests (except group delay variation and transient response tests). Refer to test equipment section of specific test for required equipment.**

1.9.2.3.4 Data Reduction. Not applicable.

1.9.3 Frequency Response Test (1) and (2).

1.9.3.1 Purpose. This test ensures that the frequency response of a channel is correct.

1.9.3.2 Test Equipment. Sine-wave generator, frequency counter, true rms voltmeter, and oscilloscope.

1.9.3.3 Test Method.

1.9.3.3.1 Setup. Connect the test equipment as shown in Figure 1-17.

1.9.3.3.2 Conditions. None.

1.9.3.3.3 Procedure.

1.9.3.3.3.1 Using a 0.1 sine wave reference frequency signal as specified in Table 6-8, Chapter 6 of IRIG Standard 106, measure frequency response by maintaining the input sine-wave signal at a constant amplitude (100 percent carrier modulation level at the reference frequency).

1.9.3.3.3.2 Monitor the reproduce output signal amplitude at various frequencies in the passband specified in Table 6-8 Chapter 6 of IRIG Standard 106 including the maximum modulation frequency.

1.9.3.3.4 Data Reduction. Observe the maximum and minimum excursions of the reproduced output level and log in dB. See appendix III-A, paragraph 1.10.

1.9.4 Signal-To-Noise Ratio Test (1) and (2).

1.9.4.1 Purpose. This test determines the SNR at the reproducer output.

1.9.4.2 Test Equipment. True rms voltmeter, sine-wave generator, frequency counter, and oscilloscope.

1.9.4.3 Test Method.

1.9.4.3.1 Setup. Connect the test equipment as shown in Figure 5-1.

1.9.4.3.2 Conditions. No external filter will be used in the measurements. The true rms voltmeter employed must be down no more than 3 dB at 10 Hz.

1.9.4.3.3 Procedure. Measure SNR by recording a 0.1 UBE sine-wave signal at a sufficient level to provide full deviation. The input to the amplifier is then shorted and the carrier recorded on the tape. The SNR measurements may be made simultaneously in the record/reproduce mode of operation. The SNR is defined as the ratio of the reproduced output signals measured under the above conditions with a true rms voltmeter.

1.9.4.3.4 Data Reduction. Not applicable.

1.9.5 Distortion Test (1) and (2).

1.9.5.1 Purpose. This test measures the harmonic distortion content and the intermodulation distortion components at the reproducer output.

1.9.5.2 Test Equipment. Wave analyzer, sine-wave generator, true rms voltmeter, frequency counter, and linear mixer.

1.9.5.3 Test Method.

1.9.5.3.1 Setup. Connect the test equipment as shown in Figure 1-17.

1.9.5.3.2 Conditions. None.

1.9.5.3.3 Procedure.

1.9.5.3.3.1 Single Component Distortion.

1.9.5.3.3.1.1 Record a 0.1 UBE sine wave signal at full deviation.

1.9.5.3.3.1.2 Measure the output of the FM reproduce amplifier with a spectrum analyzer or a wave analyzer. Measure second, third, and root-sum-square total level of harmonic distortion components.

1.9.5.3.3.2 Intermodulation Distortion.

1.9.5.3.3.2.1 Record two mixed signals, each at a level sufficient to provide one-half full deviation of the carrier.

1.9.5.3.3.2.2 Monitor the reproduced output with a spectrum analyzer or a wave analyzer and measure the IMD components of $(f_2 \pm f_1)$, $(2f_1 - f_2)$ and $(2f_2 - f_1)$ as a percent of the full deviation rms output voltage. Test frequencies are 45 and 55 percent of the maximum modulation frequency specified in Table 6-8, Chapter 6 of IRIG Standard 106.

1.9.5.3.4 Data Reduction. Not applicable.

1.9.6 Spurious Component Test (1).

1.9.6.1 Purpose. This test measures the spurious components at the reproducer output.

1.9.6.2 Test Equipment. Wave analyzer, sine-wave generator, true rms voltmeter, and frequency counter.

1.9.6.3 Test Method.

1.9.6.3.1 Setup. Connect the test equipment as shown in Figure 1-17.

1.9.6.3.2 Conditions. None.

1.9.6.3.3 Procedure.

1.9.6.3.3.1 Measure spurious components by recording the maximum modulation frequency specified in Table 6-8, Chapter 6 of IRIG Standard 106, at a level that provides full deviation.

1.9.6.3.3.2 Monitor the reproduced output with a wave analyzer.

1.9.6.3.3.3 Record the value of the largest spurious component.

1.9.6.3.4 Data Reduction. Not applicable.

1.9.7 Linearity Tests (dc) (1).

1.9.7.1 Purpose. These tests measure the linearity of FM record and reproduce amplifiers.

1.9.7.2 Test Equipment. Signal source (dc), frequency counter, and voltmeter (dc).

1.9.7.3 Test Method.

1.9.7.3.1 Setup. Connect the test equipment as shown in Figure 1-17.

1.9.7.3.2 Conditions. None.

1.9.7.3.3 Procedure. In the following measurements, frequency is used as the independent variable, while input voltage for record amplifiers and output voltage for reproduce amplifiers are the measured dependent variables. The following terms are defined as:

- f_o - Channel center frequency
- f_u - Upper band edge frequency (full positive deviation)
- f_l - Lower band edge frequency (full negative deviation)
- f_x - Frequency at fraction X of full deviation
- v_o - Voltage input or output at center
- v_u - Voltage input or output at upper level
- v_L - Voltage input or output at lower level
- v_x - Voltage measured at f_x
- x - Fraction of full channel deviation
- (voltage or frequency) $-1 \leq x \leq 1$
- e - Nonlinearity (linearity error)
- Y - Percent nonlinearity

 <p>NOTE</p>	<p>Voltages should be measured to an accuracy of 0.01 percent. Frequencies should be measured to at least 0.05 percent resolution.</p>
--	--

1.9.7.3.3.1 FM Record Amplifier Linearity.

1.9.7.3.3.1.1 Set up the amplifier per manufacturer's instructions to give output frequency f_o at selected input voltage v_o (usually 0 volts) and output frequency f_L at the selected dc input voltage v_L .

1.9.7.3.3.1.2 At as many points throughout the range of input voltage as are required, adjust input voltage to produce output frequency

$$f_x = f_o + x(f_o - f_L).$$

Measure and log input voltage.

1.9.7.3.3.1.3 Calculate error

$$e_x = v_{in} - (v_o - xv_L).$$

Record e_x .

$$Y = (e_{max}/(v_u - v_L))x 100\%.$$

1.9.7.3.3.1.4 FM Reproduce Amplifier Linearity.

1.9.7.3.3.1.5 Set up reproduce amplifier per manufacturer's instructions to give output v_o (usually 0 volts) at input frequency f_o and selected output voltage v_L at input frequency f_L .

1.9.7.3.3.1.6 At as many points throughout the range of frequencies from f_L , to f_u as are required, input frequency

$$f_x = f_o + x (f_o - f_L).$$

Measure and log output voltages. Calculate

$$e_x = v_{out} - (v_o - xv_L).$$

Record e_x .

$$Y = (e_{max}/v_u - v_L) x 100\%$$

1.9.7.3.4 Data Reduction. Plot e_x versus x for record or reproduce amplifier data or both. Points on these curves will be inside a parallelogram bounded by $x = \pm 1$ and a height equal to the peak-to-peak error. Several different types of output versus input and e versus x curves are plotted in Figure 1-18 to illustrate how the error computations and limits are applied.

1.9.8 Drift (dc) at Center Frequency Test (1).

- 1.9.8.1 Purpose. This test measures center frequency drift.
- 1.9.8.2 Test Equipment. Frequency counter and voltmeter (dc).
- 1.9.8.3 Test Method.
- 1.9.8.3.1 Setup. Connect the test equipment as shown in Figure 1-17.
- 1.9.8.3.2 Conditions. None.
- 1.9.8.3.3 Procedure.
- 1.9.8.3.3.1 Record Amplifier Center Frequency Drift (for systems without reproduce capability).
- 1.9.8.3.3.1.1 Short the input to the record amplifier.
- 1.9.8.3.3.1.2 Monitor the output frequency versus other specified parameters such as time, temperature, and line voltage.
- 1.9.8.3.3.2 System Zero Drift (including procedure for measuring record amplifier zero drift).
- 1.9.8.3.3.2.1 Proceed as in subparagraph 1.10.3.3.1.
- 1.9.8.3.3.2.2 Monitor the dc output voltage change versus other parameters as specified such as time, temperature, and line voltage. Include all changes in the frequency band dc to 0.5 Hz.
- 1.9.8.3.3.2.3 Interpret an x percent peak-to-peak specification as $\pm \frac{X}{2}$ percent.
- 1.9.8.3.4 Data Reduction. Not applicable.
- 1.9.9 Multispeed Reproduce Transfer Levels Test (1).
- 1.9.9.1 Purpose. This test measures output amplitude variations as a function of reproducer tape speed.
- 1.9.9.2 Test Equipment. Source (dc), voltmeters (dc), sine-wave oscillator, and true rms voltmeter.
- 1.9.9.3 Test Method.

1.9.9.3.1 Setup. Connect the test equipment as, shown in Figure 1-18.

1.9.9.3.2 Conditions. None.

1.9.9.3.3 Procedure.

1.9.9.3.3.1 Measure multispeed reproduce transfer levels, by recording the highest carrier frequency for which the system is equipped as specified in the Table 6-8, Chapter 6 of IRIG Standard 106, at a level sufficient to provide full deviation of the carrier at the highest tape speed of the system.

1.9.9.3.3.2 Rewind and reproduce the tape at each tape speed of the system specified for FM operation and record the output voltage monitored in each case.

1.9.9.3.4 Data Reduction. Express the output amplitude variation as a percent of the full deviation output voltage.

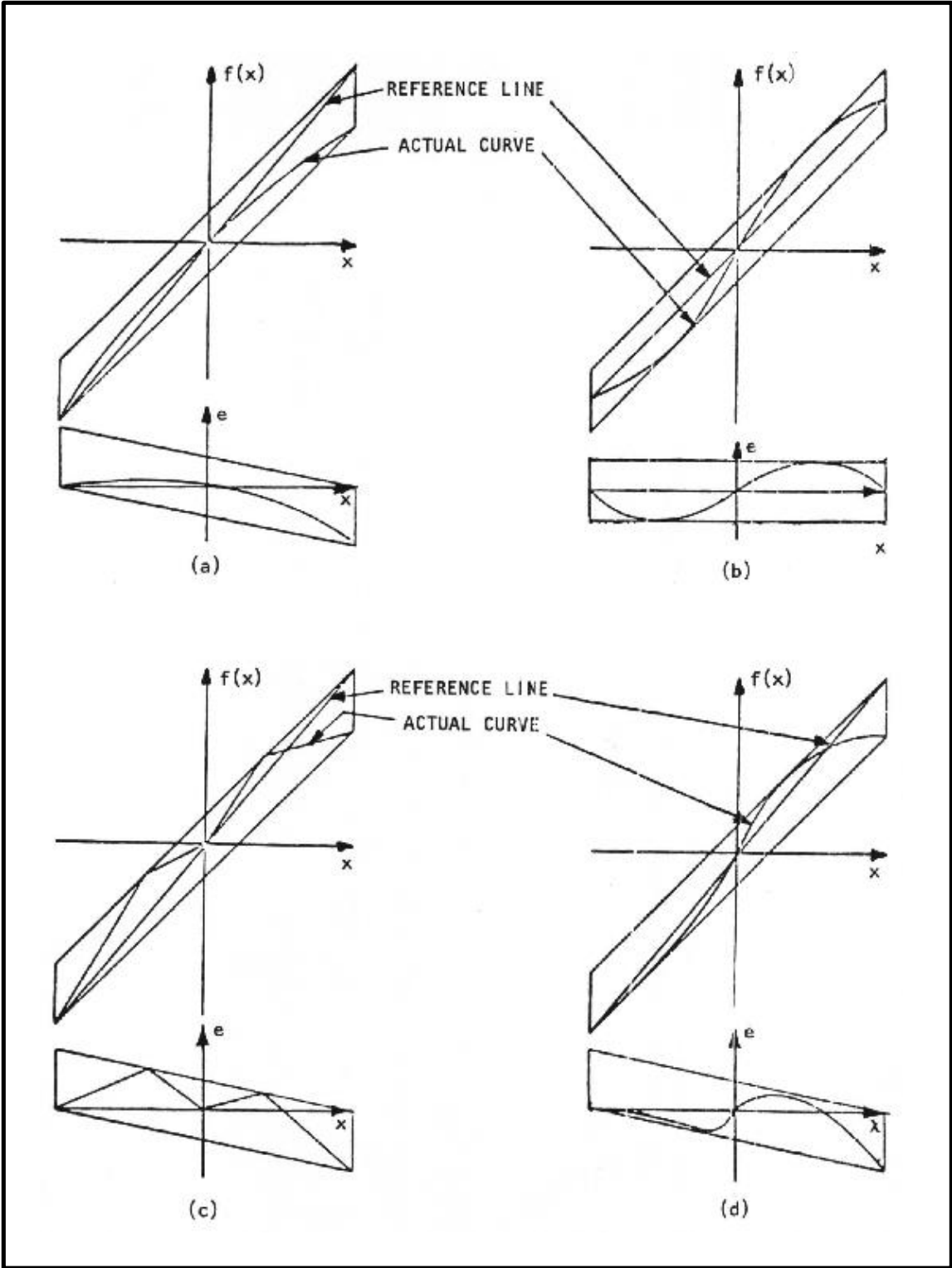

Figure 1-18. Linearity (dc) curves (see tests 1.9.7 and 1.9.9).

CHAPTER 2

SERIAL HIGH DENSITY DIGITAL RECORDING TESTS

2.1 General

This chapter defines a series of test procedures used to characterize the performance of serial high density digital recording (HDDR) systems. The procedures include tests to determine basic HDDR system performance, speed ratio, signal-to-noise ratio (SNR) margin, and bit synchronizer performance. These tests are based on the serial HDDR standards contained in Chapter 6 of IRIG 106. These standards contain the bi-phase-level (Bi ϕ -L) and randomized non-return-to-zero-level (RNRZ-L) codes for serial HDDR. Tests in paragraphs 2.2, 2.3, 2.4, and 2.5 include an analog tape recorder/reproducer in the test setup. Before these tests are performed, the analog tape recorder/reproducer should be checked and necessary actions taken to verify that

- a. the head polarities are correct;
- b. the reproduce head gaps are aligned in azimuth with the record head gaps;
- c. the bias and record levels are correct and the frequency and phase equalizers are properly adjusted;
- d. the record and reproduce heads are clean and degaussed, and the tape path is clean; and
- e. the magnetic tape is not excessively dirty. Shuttling a new reel of tape across the heads two or three times will remove much of the debris from the tape and will reduce the number of temporary dropouts. The heads and tape path should be cleaned after this procedure is completed.

2.2 Basic Serial HDDR Test (1) and (2)

Bit synchronizer testing is described in detail in volume IV of this series. In addition, see volume IV for a discussion on bit-error rate (BER) and clock-slip rate (CSR) also known as bit-slip rate.

2.2.1 Purpose. This test determines the BER and CSR of an HDDR system (including magnetic tape) at the maximum recommended IRIG bit packing density (refer to Chapter 6 of IRIG Standard 106) using a 2047-bit pseudo-random sequence.

2.2.2 Test Equipment. PCM bit synchronizer, analog tape recorder/reproducer, and pulse code modulation (PCM) test set with BER, CSR, and 2047-bit pseudo-random sequence capability.

2.2.3 Test Method.

2.2.3.1 Setup. Connect the test equipment as shown in figure 2-1.

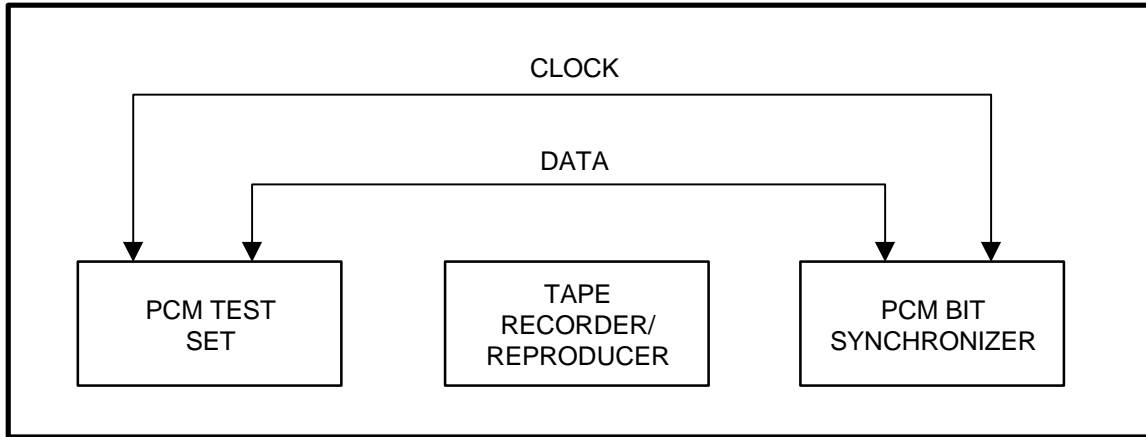



Figure 2-1. Test setup for basic serial HDDR test (see tests 2.2 and 2.3).

NOTE  **The RNRZ-L randomizer may be part of the PCM test set, tape recorder, or a separate device between the PCM test set and tape recorder. The RNRZ-L derandomizer may be part of the PCM bit synchronizer or a separate device after the PCM bit synchronizer.**

2.2.3.2 Conditions. The bit packing densities contained in this procedure are based on the assumption that the tape recorder/reproducer being tested has a nominal bandwidth of 1.0 MHz at a tape speed of 60 ips. If the tape recorder/reproducer bandwidth is different than this, the bit packing densities should be adjusted accordingly. (See Chapter 6 of IRIG Standard 106.)

Test Equipment Settings

PCM Test Set

Output code: Bi \emptyset -L
 Output pattern: 2047-bit pseudo-random sequence
 Bit rate: Set to give 15 kb/in, for example, 900 kb/s for a tape speed of 1524 mm/s (60 ips).

PCM Bit Synchronizer

Input code: Bi \emptyset -L
 Bit rate: Same as PCM Test Set

Analog Tape Recorder/Reproducer

Mode: Direct recording
 Tape speed: As desired

Input level : Adjusted to standard record level (see Chapter 6 of IRIG Standard 106).

Tracks: As desired

2.2.3.3 Procedure.

2.2.3.3.1 Record the pseudo-random Bi ϕ -L bit stream on all tracks to be tested. Rewind the tape and reproduce the Bi ϕ -L data at the same speed as the data were recorded. Measure the BER and CSR in 10 separate intervals of 10^7 bits for each track. Record the data on Data Sheet 2-1.

2.2.3.3.2 Repeat subparagraph 2.2.3.3.1 using randomized NRZ-L (RNRZ-L) at a bit packing density of 25 kb/in. Record the data on Data Sheet 2-1.

2.2.3.4 Data Reduction. The BER should be less than 10^{-6} and the CSR should be 0 in at least 9 of the 10 intervals tested for each track. If not, the alignment of the recorder/reproducer and the cleanliness of the tape, tape path, and heads should be checked. If any problems are discovered, they should be corrected and the test repeated. If the results are still unsatisfactory, the PCM bit synchronizer should be tested (see paragraph 2.6). If the PCM bit synchronizer fails the test in paragraph 2.6, replace it with a PCM bit synchronizer that had passed the test in paragraph 2.6 and repeat the test.

2.3 Speed Ratio Test (1)

2.3.1 Purpose. This test determines the effects of recording at one tape speed and reproducing at a different tape speed.

2.3.2 Test Equipment. See subparagraph 2.2.2.

2.3.3 Test Method.

2.3.3.1 Setup. Connect the test equipment as shown in Figure 2-1

2.3.3.2 Conditions. Same as subparagraph 2.2.3.2 except record speed is 3048 mm/s (120 ips), (6096 mm/s (240 ips) optional) and reproduce speed is Bi ϕ -L 95.2 mm/s (3-3/4 ips), (47.6 mm/s (1-7/8 ips) optional) RNRZ-L 381 mm/s (15 ips). Other tape speeds may be used if they provide a better representation of actual operational conditions.

Data Sheet 2-1 Serial High Density Digital Recording

Test 2.2: Basic Serial HDDR

Code _____ Bit Packing Density _____ kb/in

Recorder/Reproducer Manufacturer _____ Model _____

Serial No. _____ Record Speed _____ $\frac{\text{mm/s}}{(\text{ips})}$ Reproduce Speed _____ $\frac{\text{mm/s}}{(\text{ips})}$

Tape Width _____ Total No. of Tracks _____ Track Tested _____

Magnetic Tape Manufacturer _____ Type _____ Lot _____

PCM Test Set Manufacturer _____

Model _____ Serial No. _____

PCM Bit Synchronizer Manufacturer _____

Model _____ Serial No. _____

Test Personnel _____ Date _____

Test Location _____

<u>Interval</u>	<u>BER (x 10⁻⁷)</u>	<u>CSR (x 10⁻⁷)</u>
-----------------	--------------------------------	--------------------------------

1

2

3

4

5

6

7

8

9

10

2.3.3.3 Procedure.

2.3.3.3.1 Record the PCM bit stream on all tracks to be tested at a tape speed of 3048 mm/s (120 ips), (6096 mm/s (240 ips) optional), and bit packing densities of 15 kb/in for BiØ-L and 13.3 and 25 kb/in for RNRZ-L.

2.3.3.3.2 Rewind the tape and reproduce the data at a tape speed of 95.5 mm/s (3-3/4 ips) (47.6 mm/s (1-7/8 ips) optional, 381 mm/s (15 ips) for RNRZ-L). A bit packing density of 13.3 kb/in results in a reproduce bit rate of 200 kb/s at a tape speed of 381 mm/s (15 ips).

2.3.3.3.3 Measure the BER and CSR in 10 separate intervals of 10^7 bits for each track and record the data on Data Sheet 2-2.

2.3.3.4 Data Reduction. The BER should be less than 10^{-6} and the CSR should be 0 in at least 9 of the 10 intervals tested for each track. If not, the alignment of the recorder/reproducer and the cleanliness of the tape, tape path, and heads should be checked. If the PCM bit synchronizer fails the test in paragraph 2.6, replace it with a PCM bit synchronizer that had passed the test in paragraph 2.6 and repeat the test. If no problems are discovered with the tape, recorder/reproducer, or PCM bit synchronizer, repeat the speed ratio test with a minimum tape speed of twice the previous minimum tape speed. Increase the minimum tape speed by multiples of two until satisfactory results are obtained.

2.4 Signal-to-Noise Ratio Margin Test (Using Input Attenuator) (1)

2.4.1 Purpose. This test determines the SNR margin in the HDDR system. The SNR margin is defined as the attenuation of the input signal that increases the BER to 10^{-5} . See paragraph 2.5 for an alternate method for measuring SNR margin.

2.4.2 Test Equipment. PCM test set, step attenuator (1-dB steps), amplifier (variable gain), tape recorder/reproducer, and PCM bit synchronizer.

2.4.3 Test Method.

2.4.3.1 Setup. Connect the test equipment as shown in Figure 2-2.

Data Sheet 2-2 Serial High Density Digital Recording

Test 2.3: Speed Ratio

Code _____ Bit Packing Density _____ kb/in

Recorder/Reproducer Manufacturer _____ Model _____

Serial No. _____ Record Speed _____ $\frac{\text{mm}}{\text{s}}$ (ips) Reproduce Speed _____ $\frac{\text{mm}}{\text{s}}$ (ips)

Tape Width _____ Total No. of Tracks _____ Track Tested _____

Magnetic Tape Manufacturer _____ Type _____ Lot _____

PCM Test Set Manufacturer _____

Model _____ Serial No. _____

PCM Bit Synchronizer Manufacturer _____

Model _____ Serial No. _____

Test Personnel _____ Date _____

Test Location _____

<u>Interval</u>	<u>BER (x 10⁻⁷)</u>	<u>CSR (x 10⁻⁷)</u>
-----------------	--------------------------------	--------------------------------

1

2

3

4

5

6

7

8

9

10

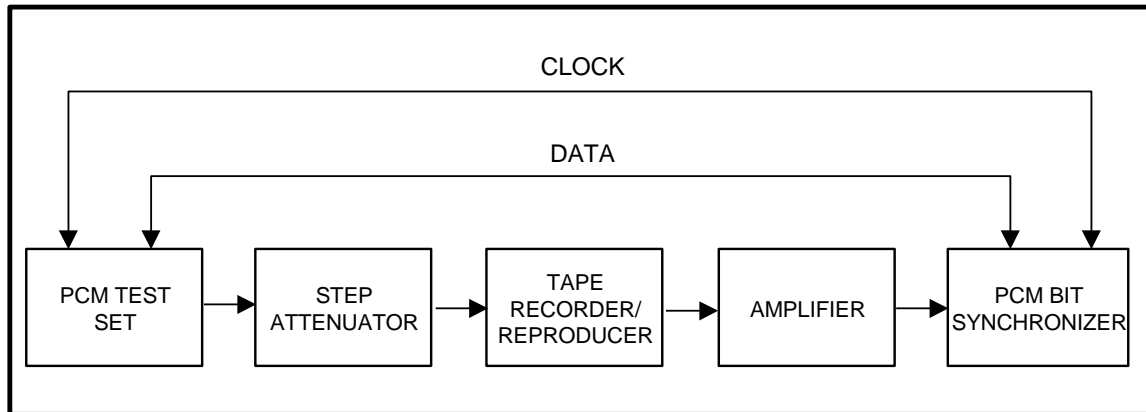



Figure 2-2. Test setup for SNR margin test (Attenuation Method) see test 2.3).

NOTE  The RNRZ-L randomizer may be part of the PCM test set, tape recorder, or a separate device between the PCM test set and tape recorder. The RNRZ-L derandomizer may be part of the PCM bit synchronizer or a separate device after the PCM bit synchronizer.

2.4.3.2 Conditions. See subparagraph 2.2.3.2 for test equipment settings.

2.4.3.3 Procedure.

2.4.3.3.1 Record the pseudo random Bi0-L bit stream on the track to be tested with the attenuator set at 0 dB. The signal level should be the same as the standard record level for serial HDDR.

2.4.3.3.2 Increase the attenuation, but keep the signal input within its operating range in the PCM bit synchronizer.

2.4.3.3.3 Monitor the bit errors per 10^5 bits at each attenuator setting. When the BER is approximately 10^{-5} , stop changing the attenuation.

2.4.3.3.4 Change the BER measurement interval to 10^6 bits. Most of the intervals should contain between 5 to 20 bit errors. If more than 20 errors are usually observed, decrease the attenuation until the number of errors per measurement interval is between 5 and 20. If less than 5 errors are usually observed, increase the attenuation until the number of errors per measurement interval is between 5 and 20. The attenuation (in dB) which produces a BER of approximately 10^{-5} is defined as the SNR margin. A different BER can be used if desired (such as 10^{-6}).

2.4.3.3.5 Record the SNR margin on Data Sheet 2-3.

Data Sheet 2-3 Serial High Density Digital Recording

Test 2.4: Signal-to-Noise Ratio Margin (with attenuation)

Recorder/Reproducer Manufacturer _____ Model _____

Serial No. _____

Tape Width _____ Total No. of Tracks _____ Track Tested _____

Magnetic Tape Manufacturer _____ Type _____ Lot _____

PCM Test Set Manufacturer _____

Model _____ Serial No. _____

PCM Bit Synchronizer Manufacturer _____

Model _____ Serial No. _____

Test Personnel _____ Date _____

Test Location _____

Code	<u>BiØ-L</u>	Tape Speed	_____	mm/s (ips)	Density	<u>15</u>	kb/in	SNR Margin	<u>db</u>
Code	<u>RNRZ-L</u>	Tape Speed	_____	mm/s (ips)	Density	<u>25</u>	kb/in	SNR Margin	<u>db</u>
Code	<u>RNRZ-L</u>	Tape Speed	<u>381</u> <u>15</u>	mm/s (ips)	Density	<u>13.3</u>	kb/in	SNR Margin	<u>db</u>
Code	_____	Tape Speed	_____	mm/s (ips)	Density	_____	kb/in	SNR Margin	<u>db</u>
Code	_____	Tape Speed	_____	mm/s (ips)	Density	_____	kb/in	SNR Margin	<u>db</u>
Code	_____	Tape Speed	_____	mm/s (ips)	Density	_____	kb/in	SNR Margin	<u>db</u>
Code	_____	Tape Speed	_____	mm/s (ips)	Density	_____	kb/in	SNR Margin	<u>db</u>
Code	_____	Tape Speed	_____	mm/s (ips)	Density	_____	kb/in	SNR Margin	<u>db</u>
Code	_____	Tape Speed	_____	mm/s (ips)	Density	_____	kb/in	SNR Margin	<u>db</u>
Code	_____	Tape Speed	_____	mm/s (ips)	Density	_____	kb/in	SNR Margin	<u>db</u>
Code	_____	Tape Speed	_____	mm/s (ips)	Density	_____	kb/in	SNR Margin	<u>db</u>
Code	_____	Tape Speed	_____	mm/s (ips)	Density	_____	kb/in	SNR Margin	<u>db</u>
Code	_____	Tape Speed	_____	mm/s (ips)	Density	_____	kb/in	SNR Margin	<u>db</u>
Code	_____	Tape Speed	_____	mm/s (ips)	Density	_____	kb/in	SNR Margin	<u>db</u>

2.4.3.3.6 Repeat subparagraphs 2.4.3.3.1 through 2.4.3.3.5 using RNRZ-L at a bit packing density of 25 kb/in. Record the SNR margin on Data Sheet 2-3.

2.4.3.3.7 Repeat subparagraphs 2.4.3.3.1 through 2.4.3.3.5 using RNRZ-L at a bit rate of 200 kb/s and a tape speed of 381 mm/s (15 ips). Record the SNR margin on Data Sheet 2-3.

2.4.3.3.8 Repeat subparagraphs 2.4.3.3.1 through 2.4.3.3.5 using Bi ϕ -L or RNRZ-L at other bit packing densities of interest (if desired). Record the SNR margin on Data Sheet 2-3.

2.4.3.4 Data Reduction. The SNR margins should be 10 dB or greater. If the margins are less than 10 dB, the HDDR system may be overly susceptible to tape dropouts and may require a reduction in the maximum bit packing density.

2.5 Signal-to-Noise Ratio Margin Test (Using Additive Noise) (1)

2.5.1 Purpose. This test determines the SNR margin in the HDDR system. The SNR margin is defined as the increase in noise at the reproduce output which increases the BER to 10^{-5} . See paragraph 2.4 for an alternate method for measuring SNR margin.

2.5.2 Test Equipment. PCM test set, amplifier (variable gain), summing amplifier, tape recorder/reproducer, PCM bit synchronizer, and true rms voltmeter (100 Hz to 5 MHz minimum bandwidth).

2.5.3 Test Method.

2.5.3.1 Setup. Connect the test equipment as shown in Figure 2-3. This test may be difficult to perform if the PCM bit synchronizer is an integral part of the reproduce amplifier card.

2.5.3.2 Conditions. See subparagraph 2.2.3.2 for test equipment settings.

2.5.3.3 Procedure.

Record the pseudo L bit stream on the track to be tested.

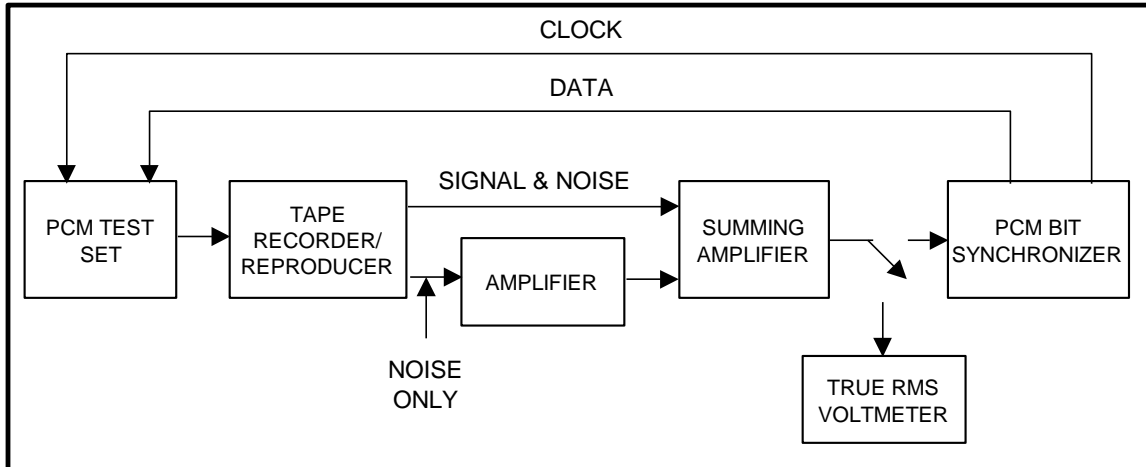

Figure 2-3. Test setup for SNR margin test (using additive noise) (see test 2.5).



The RNRZ-L randomizer may be part of the PCM test set, tape recorder, or a separate device between the PCM test set and tape recorder. The RNRZ-L derandomizer may be part of the PCM bit synchronizer or a separate device after the PCM bit synchronizer.

2.5.3.3.1 Connect the output of a second track to the amplifier. Both tracks must be properly equalized; that is, the frequency response must conform to that stipulated in Chapter 6, IRIG Standard 106, to provide the proper noise spectrum. The input to the second track should be loaded with its characteristic impedance (no input signal). While recording and reproducing the Biø-L bit stream, increase the level of the noise out of the second track until the BER is approximately 10^{-5} . The output amplifier of the recorder/reproducer can be used to provide at least part of the additional gain.

2.5.3.3.2 Measure the rms value of the output noise of the track under test (record and reproduce with no input signal) and the rms value of the output noise of the second track. The noise should be measured at the input to the PCM bit synchronizer. This measurement can be done by disconnecting the track which is not being measured from the summing amplifier.

2.5.3.3.3 Record the rms values on Data Sheet 2-4. Also, measure and record the rms value of the PCM bit stream plus noise of the output of the track being tested. In addition, this measurement should be made at the input to the PCM bit synchronizer.

2.5.3.3.4 Repeat subparagraphs 2.5.3.3.1 through 2.5.3.3.4 using RNRZ-L at a bit packing density of 9.84 kb/cm (25 kb/in). Record the results on Data Sheet 2-4.

2.5.3.3.5 Repeat subparagraphs 2.5.3.3.1 through 2.5.3.3.4 using RNRZ-L at a bit rate of 200 kb/s and a tape speed of 381 mm/s (15 ips). Record the results on Data Sheet 2-4.

Data Sheet 2-4 Serial High Density Digital Recording

Test 2.5: Signal-to-Noise Ratio Margin (with additive noise)

Recorder/Reproducer Manufacturer _____ Model _____

Serial No. _____

Tape Width _____ Total No. of Tracks _____ Track Tested _____

Magnetic Tape Manufacturer _____ Type _____ Lot _____

PCM Test Set Manufacturer _____

Model _____ Serial No. _____

PCM Bit Synchronizer Manufacturer _____

Model _____ Serial No. _____

Test Personnel _____ Date _____

Test Location _____

Code _____ Tape Speed _____ (ips) ^{mm/s} Bit Packing Density _____ kb/in
Signal + Noise ___ V rms Noise ___ V rms Noise (added) ___ V rms SNR Margin ___ db

Code _____ Tape Speed _____ (ips) ^{mm/s} Bit Packing Density _____ kb/in
Signal + Noise ___ V rms Noise ___ V rms Noise (added) ___ V rms SNR Margin ___ db

Code _____ Tape Speed _____ (ips) ^{mm/s} Bit Packing Density _____ kb/in
Signal + Noise ___ V rms Noise ___ V rms Noise (added) ___ V rms SNR Margin ___ db

Code _____ Tape Speed _____ (ips) ^{mm/s} Bit Packing Density _____ kb/in
Signal + Noise ___ V rms Noise ___ V rms Noise (added) ___ V rms SNR Margin ___ db

Code _____ Tape Speed _____ (ips) ^{mm/s} Bit Packing Density _____ kb/in
Signal + Noise ___ V rms Noise ___ V rms Noise (added) ___ V rms SNR Margin ___ db

Code _____ Tape Speed _____ (ips) ^{mm/s} Bit Packing Density _____ kb/in
Signal + Noise ___ V rms Noise ___ V rms Noise (added) ___ V rms SNR Margin ___ db

2.5.3.3.6 Repeat subparagraphs 2.5.3.3.1 through 2.5.3.3.4 using Bi ϕ -L at other bit packing densities of interest (if desired). Record the results on Data Sheet 2-4.

2.5.3.4 Data Reduction. The SNR margin is calculated from

$$\text{SNR Margin (dB)} = 20 \log_{10} \frac{\text{Noise (added) V rms} + 1}{\text{Noise V rms}}$$

where

Noise = Noise from track being tested

Noise (added) = Noise from second track

The SNR margin should be 10 dB or greater. If the margin is less than 10 dB, the HDDR system may be overly susceptible to tape dropouts and may require a reduction in the maximum bit packing density.

2.6 Serial HDDR PCM Bit Synchronizer Test (1)

2.6.1 Purpose. This test measures the performance of the PCM bit synchronizer under simulated HDDR conditions as well as the effects at low-pass and high-pass filtering and non-white noise.

2.6.2 Test Equipment. PCM test set, linear phase bandpass filter (4-pole), summing amplifier, low-pass filter (4-pole), PCM bit synchronizer, true rms voltmeter, noise source, and tape recorder/reproducer output or white noise plus spectral conditioning to simulate recorder/reproducer output (see Figure 2-4).

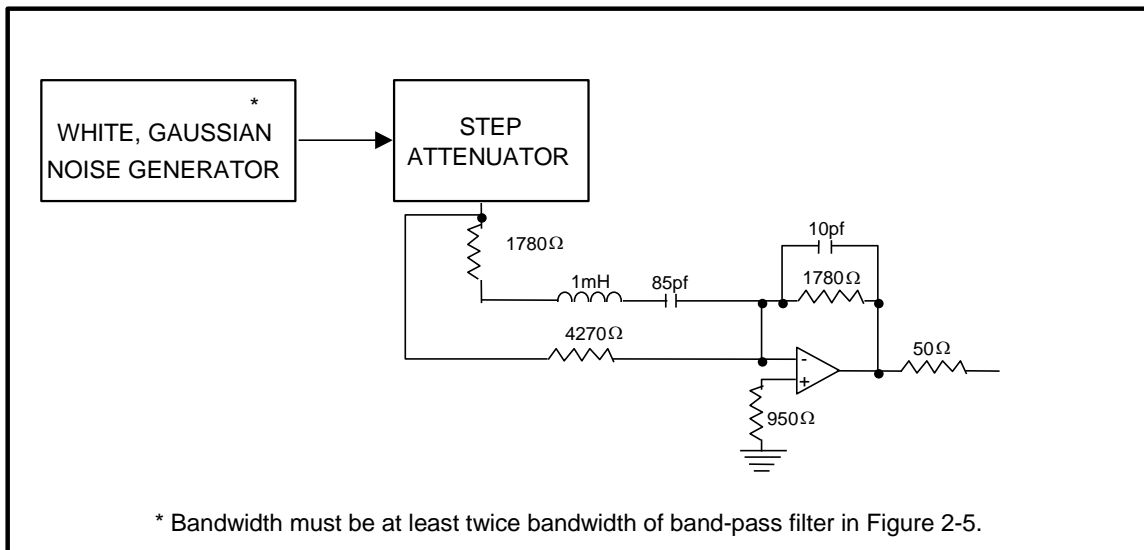

Figure 2-4. Circuit for specially conditioning white noise. (Component values are for 762 mm/s (30ips)). (see test 2.6).

2.6.3 Test Method.

2.6.3.1 Setup. Connect the test equipment as shown in Figure 2-5.

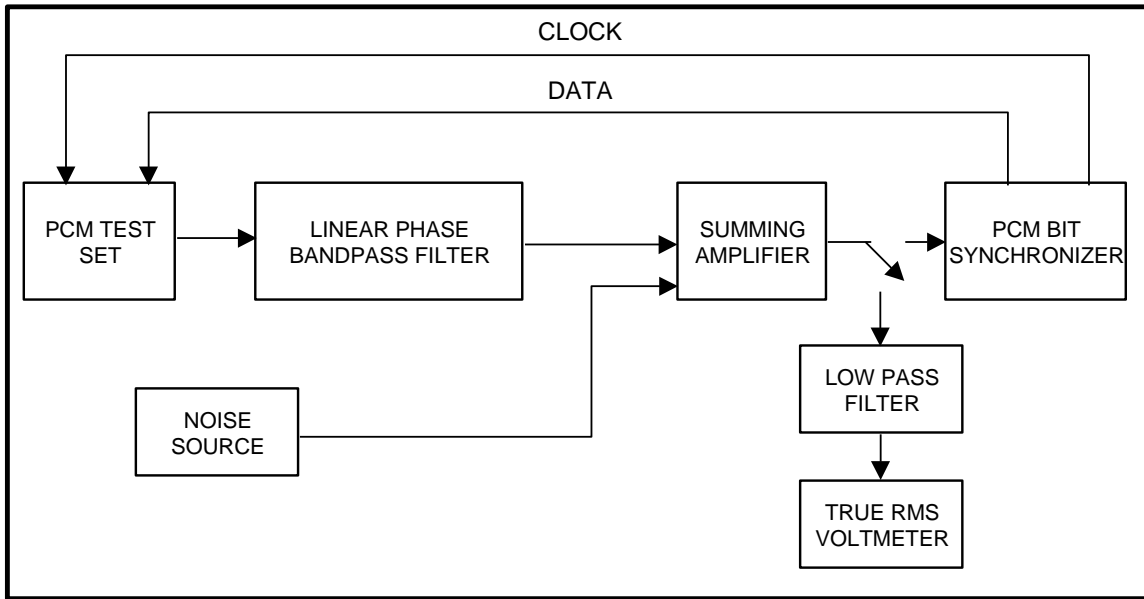



Figure 2-5. Test setup for serial HDDR PCM bit synchronizer test (see test 2.6).

NOTE  **The RNRZ-L randomizer may be part of the PCM test set, tape recorder, or a separate device between the PCM test set and tape recorder. The RNRZ-L derandomizer may be part of the PCM bit synchronizer or a separate device after the PCM bit synchronizer.**

2.6.3.2 Conditions.

Test Equipment Settings

PCM Test Set

Output Code: Bi ϕ -L or RNRZ-L

Output pattern: 2047-bit pseudo-random sequence

Bit rate: 0.9 times band-pass filter high frequency for Bi ϕ -L, 1.5 times band-pass filter high frequency for RNRZ-L.

PCM Bit Synchronizer

Input code: Bi ϕ -L or RNRZ--L

Bit rate: Same as PCM Test Set

Band-Pass Filter

Type: Bessel or RC

High-Pass: 400 or 800 Hz (6096 mm/s (240 ips))

Low-Pass: 500 kHz, 1 MHz, 2 MHz, or 4 MHz

Low-Pass Filter

Same cutoff frequency as low-pass section of band-pass filter.

Recorder/Reproducer (if used)

Stopped with appropriate tape speed selected

2.6.3.3 Procedure.

2.6.3.3.1 The Bi ϕ -L signal amplitude at the input to the bit synchronizer should be approximately 1 V rms when the PCM bit rate is equal to one-fifth of the high frequency cutoff of the band-pass filter (noise disconnected from summing amplifier).

2.6.3.3.2 Measure the rms value of the PCM signal at this bit rate and record on Data Sheet 2-5. Increase the noise level until the BER is approximately 10^{-6} .

2.6.3.3.3 Measure the rms value of the noise at the input to the PCM bit synchronizer (PCM signal disconnected from summing amplifier).

2.6.3.3.4 Record the measured values on Data Sheet 2-5.

2.6.3.3.5 Repeat subparagraphs 2.6.3.3.1 through 2.6.3.3.4 using an RNRZ-L bit stream. Record the measured values on Data Sheet 2-5.

2.6.3.3.6 Repeat subparagraphs 2.6.3.3.1 through 2.6.3.3.4 using a 200 kb/s RNRZ-L bit stream (400 Hz high-pass filter) only. Record the measured values on Data Sheet 2-5.

2.6.3.4 Data Reduction. Not applicable.

Data Sheet 2-5 Serial High Density Digital Recording

Test 2.6: PCM Bit Synchronizer

Bit Synchronizer Manufacturer _____ Model _____ Serial No. _____

Band-Pass Filter Model _____

Noise Source: Recorder/Reproducer / / Spectrally Conditioned White Noise / /

PCM Code _____ Bit Rate _____ kb/s Loop BW _____ High-Pass Frequency _____ Hz
Low-Pass Frequency _____ kHz PCM Signal _____ V rms Noise _____ V rms
SNR for 10^{-6} BER _____ dB

PCM Code _____ Bit Rate _____ kb/s Loop BW _____ High-Pass Frequency _____ Hz
Low-Pass Frequency _____ kHz PCM Signal _____ V rms Noise _____ V rms
SNR for 10^{-6} BER _____ dB

PCM Code _____ Bit Rate _____ kb/s Loop BW _____ High-Pass Frequency _____ Hz
Low-Pass Frequency _____ kHz PCM Signal _____ V rms Noise _____ V rms
SNR for 10^{-6} BER _____ dB

PCM Code _____ Bit Rate _____ kb/s Loop BW _____ High-Pass Frequency _____ Hz
Low-Pass Frequency _____ kHz PCM Signal _____ V rms Noise _____ V rms
SNR for 10^{-6} BER _____ dB

PCM Code _____ Bit Rate _____ kb/s Loop BW _____ High-Pass Frequency _____ Hz
Low-Pass Frequency _____ kHz PCM Signal _____ V rms Noise _____ V rms
SNR for 10^{-6} BER _____ dB

PCM Code _____ Bit Rate _____ kb/s Loop BW _____ High-Pass Frequency _____ Hz
Low-Pass Frequency _____ kHz PCM Signal _____ V rms Noise _____ V rms
SNR for 10^{-6} BER _____ dB

PCM Code _____ Bit Rate _____ kb/s Loop BW _____ High-Pass Frequency _____ Hz
Low-Pass Frequency _____ kHz PCM Signal _____ V rms Noise _____ V rms
SNR for 10^{-6} BER _____ dB

CHAPTER 3

DIGITAL CASSETTE HELICAL SCAN RECORDING TESTS

3.1 General

This chapter defines the test procedures for 19-mm (0.75-inch) ID-1 and 12.65-mm (0.5-inch) S-VHS digital cassette helical scan recording systems. The procedures include the use of a calibration tape to verify the proper format and performance, bit error rate tests to verify system operation, time scaled playback test to verify playback at lower data rates, polarity test to verify input and output polarity, eye pattern test for determining distortion, and verification of the longitudinal tracks.

3.2 Calibration Tape (1)

Calibration tapes are used to ensure interchange of recorded tapes among recorders/reproducers from the same and different manufacturers.

3.2.1 19-mm ID-1 Systems. The ANSI X3.175-1990⁴ standard defines the footprint requirements for interchanging recorded tapes from 19-mm ID-1 systems. Interchange success can only be assured if allowable tolerances of format parameters and recorded data characteristics for both the recorder and the playback machines are compatible as a system. The ANSI B5 ITG 96-34⁵, Crossplay Calibration Recommendations for ID-1, is a recommended practice appendix to ANSI X3.175-1990 for the purpose of establishing the use of a crossplay calibration tape and reference tapes for record/ reproduce system adjustment to ensure high performance fraternal and non-fraternal crossplay of ID-1 tapes.

It is recommended that a standard calibration tape representing the optimized flux pattern on tape, conforming to the ANSI standard, be used to assure uniform condition for interchange. The Crossplay Calibration Tape (CCT) will provide for optimizing the playback equalization parameters of each machine for successful interchange and operational compliance to the intent of the standard. The record characteristics shall be matched to those of the CCT; this will allow optimal data retrieval through the previously calibrated playback channel for any record channel which was calibrated to the CCT.

3.2.2 One-half Inch S-VHS Systems. It is recommended that calibration tapes be used for the 32 Mbps standard density⁶ and 64 Mbps high density⁷ VLDS formats. These tapes must be created on a specific master deck which is maintained and used only for this purpose. All parameters of the tape transport must be measured and verified to conform to the tape format specifications as shown in Figure 6-12 of IRIG Standard 106. Tape transport parameters are

⁴ Available from American National Standards Institute, 1430 Broadway, New York, NY 10018.

⁵ Available from American National Standards Institute; 1430 Broadway, New York, NY 10018.

⁶ Metrum 32 Mbps, part number 16828700-007 or equivalent. Available from Metrum, Inc., 4800 Dry Creek Road, Littleton, CO 80122.

⁷ Metrum 64 Mbps, part number 16828700-008 or equivalent. Available from Metrum, Inc., 4800 Dry Creek Road, Littleton, CO 80122.

measured by recording, then developing the tape, and optically measuring the magnetic signature on tape using a precision optical measurement system.

Calibration tapes are created using a pseudo random data generator as the data source for the data portion of the helical tracks of the recording. The number of principal block numbers (PBN) or data blocks must be tightly controlled as it is used to determine the absolute X value (X value is the distance between the beginning of the first helical swipe in a principal block and the location of the corresponding control track pulse). In addition, a 1-KHz tone should be recorded on the longitudinal direct channel track for use in mechanical alignment of the control track/filemark head stack. Pulses should also be recorded on the file mark track synchronous with the control track pulses for use in adjusting the azimuth of the control track/filemark head stack.

3.3 Bit Error Rate (BER) Test (1) and (2)

This test determines the corrected BER (CBER) of a helical scan recording system (including magnetic tape) at the maximum recommended packing density of the system. This test is performed with the Error Detection and Correction (EDAC) enabled.

3.3.1 Test Equipment. Bit Error Rate Test Set – a test set that generates pseudo-random bit sequences at bit rates up to the maximum bit rate of the system under test and measures the resulting bit error rate. The output of the test set shall be 8-bit parallel, byte serial format with a clock signal at the required byte rate for the 19-mm systems and 8- or 16-bit parallel or bit serial for the one-half inch systems. Bit error rates (BERs) shall be displayed as the arithmetic average and peak values.

3.3.2 Procedure.

3.3.2.1 Connect the test set generator output to the input of the tape recorder system under test and the tape recorder output to the test set receiver section.

3.3.2.2 Set the test set to pseudo-random bit sequence PRN-23 ($2^{23} - 1$ length) at a bit rate that results in the maximum packing density of the recorder under test and record the signal for a minimum of 10 minutes.

3.3.2.3 Rewind the tape and measure the bit error rate as the tape is being reproduced.

3.3.3 Data Reduction. Record the highest and lowest bit error rate readings and verify that the system meets specifications. Tape induced burst errors should be excluded. When tape induced burst errors are suspected, the tape should be replayed to determine the location of the errors. If the error location remains the same, the tape should be degaussed, re-recorded, and re-tested. If the error location is retained, that error will be considered a permanent tape error for the purposes of the BER calculation.

3.4 Time Scaled Playback Test (1) and (2)

This test verifies the capability to playback recorded data at lower rates such as one-half, one-fourth, and one-eighth of original rate.

3.4.1 Test Equipment. Bit Error Rate Test Set.

3.4.2 Procedure.

3.4.2.1 Playback tape recorder in paragraph 3.3 at one-half rate and note bit error rate.

3.4.2.2 Repeat at playback rates of one-fourth and one-eighth rates and note the bit error rate.

3.4.3 Data Reduction. Compare bit error rates with the bit error rate achieved when played back at the original speed.

3.5 Polarity Test (1)

This test ensures the polarity of the digital signal at the output of the reproduce electronics is the same as the polarity of the signal at the input to the record electronics.

3.5.1 Test Equipment. Bit Error Rate Test Set, calibration tape (see paragraph 3.1).

3.5.2 Procedure.

3.5.2.1 Reproduce a PCM test signal of known polarity from the calibration tape and note the polarity at the output of the reproduce electronics using a polarity sensitive bit error rate test set.

3.5.2.2 Set the bit error rate test set at the same bit rate and polarity as noted above. Record the signal.

3.5.3 Data Reduction. Verify the bit error rate test set locks up. If the test set does not lock up, invert the polarity of the test set receive section and verify lock. The test fails if the test set does not lock up without inverting the polarity.

3.6 Eye Pattern (1)

The eye pattern test is useful for determining the distortion of a pulse code modulation (PCM) signal. The distortion can result in jitter in the time crossings and reduction in the signal amplitude. The distortion is typically caused by a combination of non-constant group delay and filtering.

3.6.1 Test Equipment. Pseudo-noise (PN) generator, oscilloscope, bit synchronizer, plotter, or oscilloscope camera (optional).

3.6.2 Procedure.

3.6.2.1 Connect test equipment as shown in Figure 1-12.

3.6.2.2 Set the bit rate and code of the PN generator and bit synchronizer to the desired values. Set the oscilloscope to trigger on the clock signal from the bit synchronizer. Start the recorder and adjust the oscilloscope amplitude and time base controls to produce a display similar to those in Figures 1-13, 1-14, 1-15, and 1-16. The signals shown in Figures 1-13 and 1-14 had bit error rates of essentially zero. The signals shown in Figures 1-15 and 1-16 had approximately 1 error per 100,000 bits.

3.6.2.3 Measure the peak-to-peak time jitter, nominal peak-to-peak amplitude, and peak-to-peak amplitude at the center of the eye opening. Record these values on Data Sheet 1-1. If the appropriate equipment is available, plot or photograph the oscilloscope display and attach to the data sheet.

3.6.3 Data Reduction. Multiply the time jitter by the bit rate and multiply this result by 100 to get the peak-to-peak jitter as a percentage of the bit period. Divide the minimum eye opening by the nominal eye opening and multiply by 100 to get the percentage eye opening. For example, in Figure 1-14 the peak-to-peak jitter is approximately 12 percent of a bit period and the eye is approximately 80 percent open. The corresponding values for Figure 1-16 are 26 percent and 17 percent, respectively.

3.7 Longitudinal Track Tests (1) and (2)

These tests determine the bias, record levels, frequency response, and wideband signal-to-noise ratios of the longitudinal tracks of the digital cassette helical scan recorders.

3.7.1 Test Equipment. Signal generator, spectrum analyzer, and RMS voltmeter.

3.7.2 Procedure.

3.7.2.1 Connect the test equipment as shown in Figure 3-1. With the signal generator set to the upper bandedge of the longitudinal track and input level set 5 to 6 dB below standard record level, record and simultaneously reproduce a tape, and adjust the bias to 2 dB overbias per manufacturer's instructions.

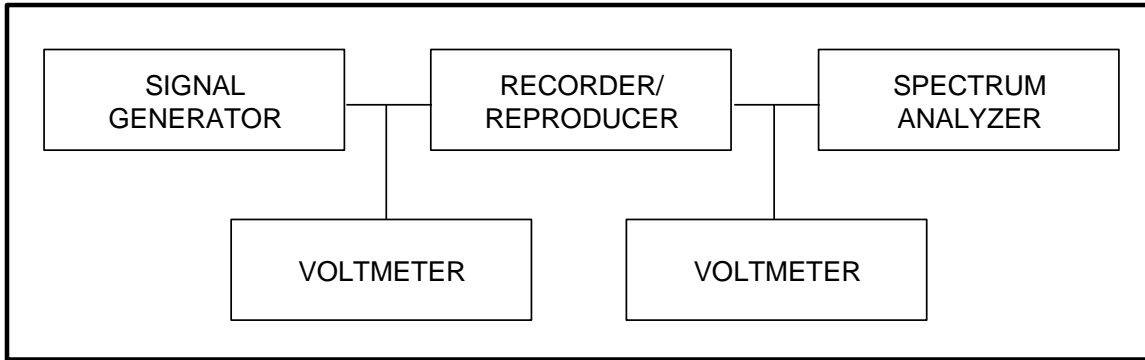

Figure 3-1. Digital recorder longitudinal track tests.

3.7.2.2 With the signal generator set to 1/10 upper bandedge (reference level) and input set to the standard record level (1 V rms), record and simultaneously reproduce a tape, and adjust the record amplifier until 1 percent (-40 dB) third harmonic distortion level is indicated by the spectrum analyzer. Measure and note the second harmonic distortion level as read on the spectrum analyzer.

3.7.2.3 With the input level of the signal generator maintained at the reference level, vary the input frequency over the frequency band of the longitudinal track and note that the maximum and minimum readings at the output of the reproduce electronics do not exceed ± 3 dB.

3.7.2.4 With the input level of the signal generator maintained at the reference level, note the output level.

3.7.2.5 While still in the simultaneous record/reproducer mode, remove the input signal and note the output level.

3.7.3 Data Reduction. The signal to noise ratio is the dB difference between the two readings.

CHAPTER 4

RECORDER MULTIPLEXER/DEMULTIPLEXER SYSTEM TESTS

4.1 General

This chapter defines the test procedures for the multiplexer/demultiplexers used as input and output to the helical scan recording systems. The procedures include bit error rate tests, measurements of delays through the system, and verification of the proper format.

4.2 Bit Error Rate Test (1) and (2)

4.2.1 General. This test determines the BER of a multiplexer/demultiplexer system at selected bit rates. This test may be run with or without the associated recorder in the loop. When the recorder is in the loop, the error correction electronics should be activated.

4.2.2 Test Equipment. Bit Error Rate Test Set - a test set that generates pseudo-random bit sequences at bit rates up to the maximum capability of the system under test and measures the resulting bit error rate. The output of the test set shall be bit serial. Bit error rates shall be displayed as the arithmetic average.

4.2.3 Procedure.

4.2.3.1 Connect the test set generator output to the input of the multiplexer system under test and the demultiplexer output to the test set receiver section.

4.2.3.2 Set the test set to pseudo-random bit sequence PRN-23 ($2^{23} - 1$ length) at selected bit rates within the capability of the system. If a tape recorder is in the test loop, record the signal for a minimum of 10 minutes.

4.2.3.3 If a tape recorder is in the test loop, rewind the tape and measure the bit error rate as the tape is being reproduced. If only the multiplexer/demultiplexer is being tested, measure the bit error rate at the output of the demultiplexer.

4.2.4 Data Reduction. Record the highest and lowest bit error rate readings and verify that the system meets specifications.

4.3 Delay Measurements (1)

4.3.1 Purpose. This test determines the time delays from the input to the multiplexer to the output of the demultiplexer. This test can be performed with the recorder bypassed (E-E mode) or with the recorder running. The absolute values of time delay are not important for this application but the differences in delay between different signals are important for time aligning data from different sources.

4.3.2 Test Equipment. PCM signal sources (NRZ data and 0 degree clock), PCM signal detectors, and counters. The PCM signal sources can be either PCM format simulators with embedded time or pseudo-noise (PN) generators with a pulse output when a unique synchronization pattern is detected (this pulse is used to start the time interval measurement). The PCM signal detectors (format simulator) detect the frame synchronization pattern, latch time, and subtract the embedded time from the current time; or (PN generator) detect a unique synchronization pattern and output a pulse to stop the time interval measurement. The resolution of the embedded time or the counters determines the time resolution of this technique. The embedded time can be either absolute time (for example GPS time) or relative time. If relative time is used the signal source and signal detector must be synchronized to each other. The number of sets of equipment is determined by the number of channels that must be tested simultaneously.

4.3.3 Test Method.

4.3.3.1 Setup. Connect test equipment as shown in Figure 4-1.

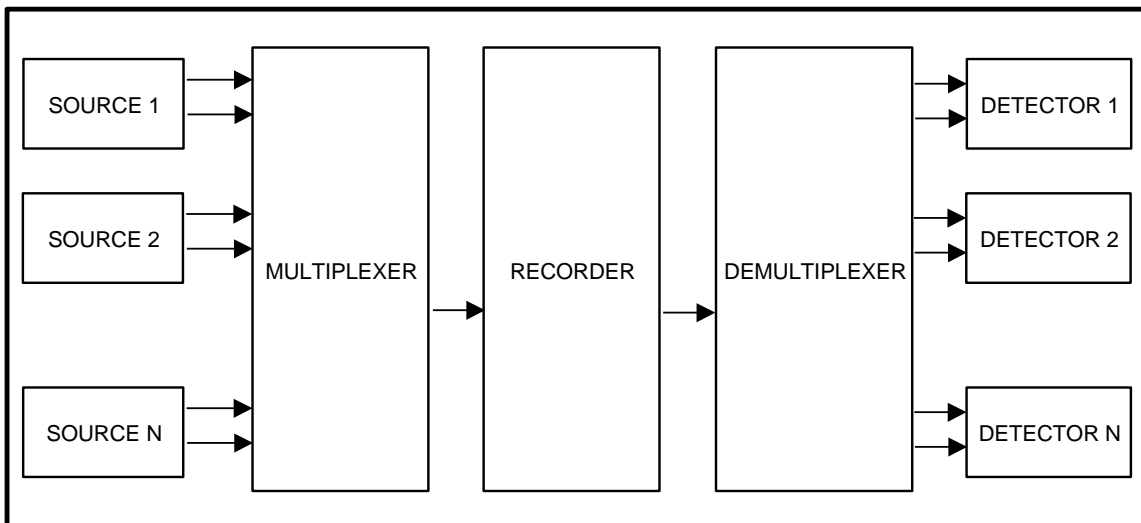

Figure 4-1. Multiplexer/demultiplexer delay measurement.

4.3.3.2 Conditions. This test can be performed with the recorder bypassed (E-E mode) or with the recorder running.

4.3.3.3 Procedure.

4.3.3.3.1 Select the bit rates to be tested and record them on Data Sheet 4.1. These bit rates should represent a cross section of the actual rates that the equipment will be used with. Bit rates near the low and high end of the equipment specifications should be applied simultaneously. Set the multiplexer for the bit rates to be tested. Verify that the aggregate bit rate does not exceed the capability of the recorder or multiplexer/demultiplexer under test.

4.3.3.3.2 Apply data and clock signals to the multiplexer input and connect the demultiplexer outputs (data and clock) to the appropriate detectors. A low bit rate signal can also be applied to the analog input if an analog input is available.

4.3.3.3.3 Measure and record on Data Sheet 4-1 the time delays with the recorder bypassed.

4.3.3.3.4 (Optional) This test can only be performed if the unambiguous time measurement interval is significantly larger than the total time required to record and reproduce the signal. For example, a 32-bit time word with 1 microsecond resolution will repeat every 4294 seconds, while a maximal length PN sequence with register length of 20 will repeat every 100 milliseconds at a bit rate of 10 Mbps. Start the recorder and record the signals for an appropriate time interval. If read after write capability exists on the recorder under test, measure and record on Data Sheet 4-1 the time delays with the recorder. For systems without read after write capability, rewind the tape and reproduce the data. Measure and record on Data Sheet 4.1 the time delays with the recorder and tape in the signal path. The delays will include the time spent recording the data and rewinding the tape.

4.3.3.4 Data Reduction. Subtract the delay in the first channel from the delays in the other channels and record as relative delay on Data Sheet 4-1.

DATA SHEET 4-1 RECORDER MULTIPLEXER/DEMULTIPLEXER SYSTEM TESTS

Test: 4.3 Delay Measurements

MUX/DEMUX Manufacturer _____ Model _____ Serial No. _____

Recorder Manufacturer _____ Model _____ Serial No. _____

Test Personnel _____ Date _____

MULTIPLEXER/DEMULTIPLEXER ONLY (RECORDER BYPASSED)

	Ch 1	Ch 2	Ch 3	Ch 4
Bit rate (Mbps)				
Delay (μ s)				
Relative delay (μ s)				

RECORDER and MULTIPLEXER/DEMULTIPLEXER

	Ch 1	Ch 2	Ch 3	Ch 4
Bit rate (Mbps)				
Delay (μ s)				
Relative delay (μ s)				

4.4 Format Verification Test (1)

4.4.1 General. This test verifies that the multiplexer/demultiplexer format, Analog to DigitalAdaptable Recorder Input/Output (ADARIO), is correct as recorded on tape. This test uses a PC based automated approach. If a tape is available that has been recorded in a known ADARIO format, an alternate method is to use the tape to verify the demultiplexer format and then use the demultiplexer to verify the multiplexer format. However, the following software method has the advantage of being able to identify the degree of format compatibility and those areas that are not compatible.

4.4.2 Test Equipment. Verification Signal Generator (VSG) - At a minimum, a fixed function, non-programmable signal generator that provides for several discrete simultaneous analog and digital outputs. The VSG produces an analog output (15 Hz to 1 MHz) sawtooth waveforms, serial digital with clock (1 Mbps and 64 Kbps), parallel digital with clock (1 Msps 16 bit word and 3.9 Ksps 8 bit word). The VSG outputs are generated from a single set of counters driven from a common crystal oscillator. This approach allows the VSG to produce time correlated signal outputs with recognizable data content features. The analog output is a series of sawtooth ramps of various amplitudes and duration derived from the counter outputs and associated digital to analog converter. Serial outputs are serialized counter outputs. Parallel outputs are derived from the counter outputs at the several clock rates (1 MHz or 3.9 MHz).

Personal Computer (PC) - an IBM compatible 486 or higher type PC with at least 8 MB memory, DOS 3.0 or higher, and a report printer. The processing rate of the PC is not a critical issue.

4.4.3 Procedure.

4.4.3.1 Connect the VSG to the multiplexer under test and select any combination of signals for recording.

4.4.3.2 Record the output of the multiplexer on the associated tape recorder.

4.4.3.3 Transfer the results of this recording to a computer compatible media for analysis.

4.4.4 Data Reduction.

4.4.4.1 Commercially available verification software⁸ will test the storage media against all the annotated fields within the ADARIO format. Within the ADARIO block this includes session static and dynamic fields, channel static and dynamic fields and fill. The ADARIO block format and its associate fields are given in IRIG Standard 106, Appendix G.

⁸ Alliant Techsystems ADARIO Format Verification Software or equivalent. Available from Alliant Techsystems, 401 Defense Highway, Annapolis, MD 21401.

4.4.4.2 The analysis process provided by the verification software is as follows:

- Correlate the blocking structure of the data using the ADARIO Word or Fill to determine beginning of data blocks.
- Analyze the content of each data field using known VSG channel data content.
- Analyze the signal data content using known VSG signal data content.
- Report on compliance or lack of compliance to ADARIO format on a per field basis.
- Report statistically on full data sample compliance to the ADARIO format.

4.4.4.3 The software reads a buffer of data approximately 60 K bytes (10 ADARIO formatted blocks) from the storage media. The software then partitions the buffer into blocks of 2048*3 bytes (ADARIO block size) and then scans these blocks for equal value bytes using a variable buffer offset from the beginning of buffer 0 to 2048*3 bytes. The software then records the number of matches per offset. The highest number of matches is the most probable ADARIO block boundary and will start at the end of the “FF” Hex fill bytes (if any are occurring). This method of correlation provides a means for locating the block boundary without dependence on data content.

4.4.4.4 The block start location will have data content that verifies the block length and provides for the location of the highest priority channel header. Block header verification is based on the IRIG Standard 106 ADARIO standard and the use of the VSG data content for format and timing verification. It is recommended that all static annotation fields be tested before conducting any dynamic testing. If any test fails, the operator will be alerted and, after testing is complete, a comprehensive test report will be generated. The software elements are as follows:

- Storage Media Data Input Control - controls flow of data to be analyzed.
- Block Correlation - locates block boundary.
- Block Header Verification - verifies session static and dynamic fields, determines master clock rate, block rate and time code, and number of active channels.
- Channel Header Locator - locates channel headers based upon the number of active channels and channel word count.
- Channel Header Verification - verifies static and dynamic fields.
- Channel Data Type Verification - verifies header versus data based upon recorded parameters.
- Data Feature Extractor/Correlator - verifies multi-channel data time correlation.
- Report Generator - provides the size of test data, number of fields that passed and failed, and the percentage of overall compatibility and adherence to ADARIO format.

CHAPTER 5

MAGNETIC TAPE TESTS

5.1 General

This chapter describes the detailed test procedures to be used in measuring the magnetic tape performance requirements outlined in Magnetic Tape Standards, Chapter 7 of IRIG Standard 106. Magnetic tape terms and definitions are also given in Chapter 7. Magnetic Media Laboratory⁹ (MML) Documents 350 Oe and 750 Oe describe additional tests and test procedures being used for qualification and acceptance tests of wideband and high energy instrumentation magnetic tape, respectively. For physical specifications and tests of 19 mm (0.75 inch) and 12.65 mm (0.5 inch) digital cassette helical scan recording tape, refer to the manufacturer's specifications as they relate to the application for which the tape will be used.

When measurement techniques are not specified, it is assumed that commonly accepted measurement methods for mechanical and electrical characteristics will be employed. Not all the test procedures described in this chapter are required for any one evaluation and tests other than those indicated may be required for a given evaluation. The quantity of tapes to be evaluated at one time will depend on the final application of the tape. For new tape, it is recommended that a statistical sampling plan be employed to specify both the quantity of tapes to be tested and the appropriate acceptance or rejection criteria. For used tape, it is recommended that all tapes be tested and that a tape be rejected if a single test fails.

To the greatest extent possible, the environmental conditions of the test area should duplicate the environmental conditions normally encountered in the operational area in which the tape is to be used. The test area should be kept as dust free as possible and the environment should be maintained at 70 degrees F \pm 5 (294.3 K \pm 2.8) and 50 percent \pm 5 relative humidity.

5.2 Manufacturer's Centerline Tape (MCT) and Manufacturer's Secondary Centerline Tape (MSCT)

As referred to in this document, a MCT is an unrecorded magnetic tape maintained by the manufacturer. A MSCT is an unrecorded magnetic tape provided by the manufacturer to the user. It shall be traceable to the appropriate MCT. Since the MSCT is used solely for the electrical performance characteristics, it does not necessarily have to represent the manufacturer's centerline performance values for physical characteristics.

During the calibration of the MSCT, a calibration factor equal to the amount of departure from the MCT is established and provided by the manufacture with the MSCT. When using the MSCT, the calibration factor will be used to obtain the end results in comparing the tape under test to the MCT.

⁹ MML Documents are available from the Naval Air Weapon Center Aircraft Division, Patuxent River, MD 20670.

Before starting the performance tests, properly align and adjust the test recorder/reproducer in accordance with the IRIG standards and manufacturer's instruction manual. After the alignment is complete, a qualitative test should be conducted to ensure the system will transport tape properly.

5.3 Longitudinally-Oriented Oxide Instrumentation Magnetic Tape

This section describes the test procedures to be used in measuring the instrumentation magnetic tape performance requirements.

5.3.1 Standard Record Conditions.

5.3.1.1 High Energy Tape. Standard record conditions for high energy (HE) tape consist of a 2.0 MHz ± 2 percent sinusoidal test signal recorded at 3048-mm/s (120-ips) tape speed or 1.525-micrometer (0.06-mil) wavelength using the specified bias and record levels.

	High resolution tape and the associated standard record conditions are recommended for HDDR requirements as specified in IRIG Standard 106. The tape and the standard record conditions for nonstandard serial and parallel HDDR should be based on the specific requirements.
---	---

5.3.1.2 High Resolution Tape. Standard record conditions for high resolution (HR) tape consist of a 1.0 MHz ± 2 percent sinusoidal test signal recorded at 3048-mm/s (120-ips) tape speed or 3.05-micrometer (0.12-mil) wavelength using the specified bias and record levels.

5.3.2 Working Tape Length. The test procedures described here are conducted over the working tape length, which is defined as the designated length of the tape under test excluding the first and last 30.48 m (100 ft).

5.3.3 Test Equipment-Level Detector and Recorder. The direct-write recorder and level-detector system described next are recommended for use in detecting and recording the magnitude and duration of the output signal level changes required in several test procedures.

5.3.4 Level Detector. The level detector is a full-wave peak ac detector whose dc output represents the amplitude of the ac signal envelope. The level detector has characteristics equal to the following minimum specifications:

- Bandpass of detected frequency: 400 kHz -to 1.0 Mz ± 1 dB or 400 kHz to 2.0 MHz ± 1 dB
- Output ripple: less than 1 percent over rated band pass
- Response of detected output: dc to 200 Hz ± 1 dB
- Output level: Sufficient to drive direct-write recorder

5.3.5 Direct-Write Recorder. The direct-write recorder used consists of a minimum of seven channels of recording capability with sufficient linearity, frequency response, and stability to

accurately record the ac detector output. The recommended chart speed to be used during the tests is approximately 1.02 mm/s (0.04 ips) and the direct-write recorder sensitivity should be approximately 2 V for full-scale deflection.

5.3.6 Durability Test Analysis Consists of

- examining the direct-write recording of the working tape length for signal losses (changes in signal level), as described in subparagraph 7.6.7, Durability, Chapter 7 of IRIG Standard 106 (see Figure 5-1, this volume). The amount of the signal loss in dB is calculated using the following equation:

$$\text{Signal Loss dB} = 20 \log_{10} \frac{\text{peak value before loss}}{\text{peak value during loss}} \quad (5-1)$$

- taking both values at the peak trace level and referencing them to the 0 V baseline of the direct-write recording. The duration of the signal loss is determined by reading directly from the longitudinal calibration marks on the direct-write recording.

5.3.7 Output Uniformity Test Analysis Consists of

- examining the direct-write recording of the working tape length on a per-track basis to determine the peak value of the highest amplitude signal recovered and the peak value of the lowest amplitude signal recovered.

- taking both values at the peak trace level and referencing them to the 0 V baseline of the direct-write recording. The change in output level is converted into dB by using the following equation:

$$\text{Uniformity(dB)} = 20 \log \frac{\text{peak deflection, high signal}}{\text{peak deflection, log signal}} \quad (5-2)$$

5.3.8 Test Procedures, Magnetic/Electrical Characteristics.

5.3.8.1 Bias Level. While using the MSCT, and referring to its associated calibration factor, adjust the test recorder/reproducer on one or more center tape tracks for the appropriate MCT bias level. After adjustment completion, set the bias level monitor meter to a convenient reference level such as 0 db on each test track. Remove the MSCT from the test recorder/reproducer and replace it with the sample tape under test. Readjust the test recorder on the same tape tracks for the appropriate bias level as specified above. The bias level requirement of the sample tape will be obtained from the bias level monitor meter and compared with the previously established MCT reference. Express the difference in levels, if any, as determined on the bias level monitor meter with a plus polarity sign if the sample tape's bias level requirement exceeds the MCT and a negative sign if the MCT exceeds the tape sample under test.

5.3.8.2 Record Level.

5.3.8.2.1 While using the MSCT and referring to its associated calibration factor, adjust the test recorder/reproducer on one or more center tape tracks for the appropriate MCT bias and record levels and optimize the reproduce equalization on all test tracks. After adjustment completion, adjust the record level monitor meter to a convenient reference level such as 0 dB on each test track.

5.3.8.2.2 Remove the MSCT from the test recorder/reproducer and replace it with the sample tape under test. Repeating all procedures previously discussed, except the record level monitor meter adjustment, determine the record level required by the manufacturer's sample tape. The difference in levels, if any, as determined on the record level monitor meter, is expressed with a plus polarity sign if the sample tape's record level requirement exceeds the MCT and a negative sign if the MCT exceeds the tape sample under test.

5.3.8.2.3 The tape has failed the test if the record level required by the tape exceeds the tolerances specified by the procuring agency.¹⁰

5.3.9 Wavelength Response and Output at 0.1 Upper Band Edge Wavelengths.



The tests in this section have been combined because the test procedures are similar to those described in previous sections.

While using the MSCT and referring to its associated calibration factor, adjust the test recorder on one or more center tape tracks for the appropriate MCT bias level. Adjust the record level for 3 to 6 db below that which would be obtained at the MCT standard record level and optimize the reproduce equalization on all test tracks. Obtain the output amplitude values at the applicable wavelengths specified in Table 5-1 in the center one-third section of the reel using the same measurement wavelengths as the MSCT. On completion of the test, the following four response curves are co-plotted with the wavelength as the abscissa using the data obtained from the previously described test:

- the absolute output readings of the MSCT corrected by the appropriate calibration factor so as to represent the MCT output in dB;
 - the uncorrected, absolute output reading of the manufacturer's sample tape in dB;
 - the output readings of the manufacturer's sample tape, after correcting the sample tape readings by the constant dB value required to overlay curves A and B at the 0.1 UBE; and
 - the difference in output between curves C and A with A used as the reference.
- The measured tape characteristics are then defined as:
- a. The output at 0.1 UBE wavelength of the sample tape is the dB difference between curves A and B at the 254-micrometer (10 mil) wavelength.

¹⁰ MML Documents are available from the Naval Air Weapon Center Aircraft Division, Patuxent River, MD 20670.

b. The wavelength response of the sample tape is curve D.

c. For both definitions, a plus sign will indicate that the sample tape's output exceeded the output of the MCT and a negative sign will indicate that the MCT output exceeded that of the sample tape.

TABLE 5-1					
WAVELENGTHS FOR WAVELENGTH RESPONSE TESTS					
Standard-Resolution Tape		High-Resolution and HDD Tape		High-Energy Tape	
<u>um</u>	<u>(mils)</u>	<u>um</u>	<u>(mils)</u>	<u>um</u>	<u>(mils)</u>
7620.00	(300.000)	3810.00	(150.000)	254.00	(10.000)
1524.00	(60.000)	254.00	(10.000)	25.40	(1.000)
254.00	(10.000)	25.40	(1.000)	12.70	(0.500)
25.40	(1.000)	6.35	(0.250)	6.35	(0.250)
12.70	(0.500)	3.18	(0.125)	3.18	(0.125)
6.35	(0.250)	2.54	(0.100)	2.54	(0.100)
3.18	(0.125)	2.03	(0.080)	1.52	(0.060)
		1.52	(0.060)	1.02	(0.040)
				0.76	(0.030)

5.3.10 Short Wavelength Output Uniformity.

5.3.10.1 While using the MSCT and referring to its associated calibration factor, adjust the test recorder/reproducer on all tape tracks for the appropriate MCT bias and record, and optimize the reproduce equalization. Remove the MSCT from the test recorder/reproducer and replace it with the sample tape under test. Using the applicable record conditions specified in subparagraph 5.3.1, Standard Record Conditions, simultaneously record and reproduce seven tracks over the working length of the tape. Individually analyze the seven output signals for long term output amplitude variations which occur along the working length of the tape, by using a suitable means of detecting and recording the output amplitude as described in subparagraph 5.3.3, Level Detector and Recorder. When using this method, the change in output amplitude uniformity of the tape under test is converted into units of dB as outlined in subparagraph 5.3.4, Output Uniformity Test Analysis (see Figure 5-1).

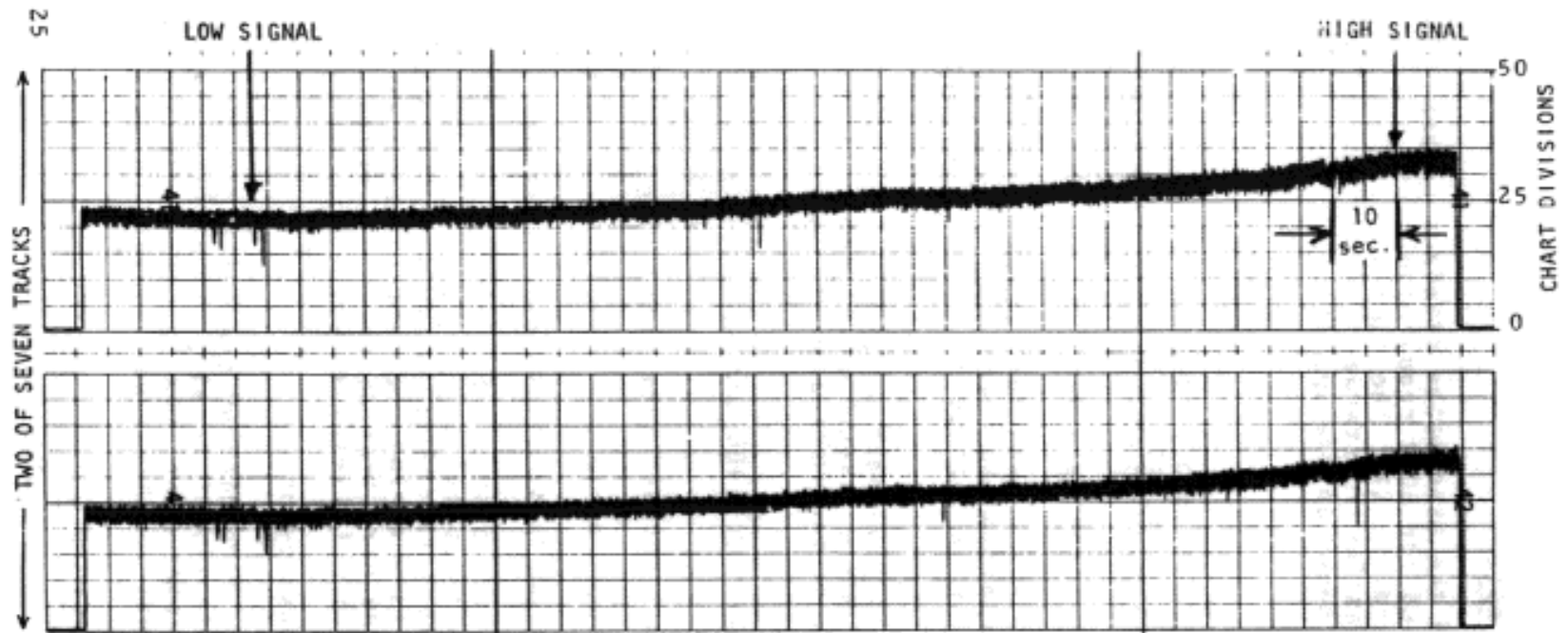

$$\text{UNIFORMITY}_{(\text{dB})} = 20 \log_{10} \frac{\text{Peak Deflection, High Signal}}{\text{Peak Deflection, Low Signal}}$$

$$\begin{aligned} \text{UNIFORMITY} &= 20 \log_{10} \frac{(34,0 \text{ div.})}{(23,0 \text{ div.})} \\ (\text{Top Trace}) & \\ &= 3,4 \text{ dB} \end{aligned}$$

Figure 5-1. Output uniformity test analysis (see tests 5.3.3 and 5.3.8).

5.3.10.2 The tape has failed the test, when the long term output uniformity of the peak level of the signal trace on any track exceeds those limits specified by the procuring agency for Short Wavelength Output Uniformity.

5.3.10.2.1 In the event that a tape fails an output uniformity test, and tension variation of the test recorder/reproducer is suspected, retest the failed tape in the reverse direction to separate the tape non-uniformity from the effects of tension variations.

5.3.11 Short Wavelength Instantaneous Non-Uniformity (Dropout).

5.3.11.1 While using the MSCT and referring to its associated calibration factor, adjust all tape tracks for the appropriate MCT bias and record level as outlined and optimize the reproduce equalization. Remove the MSCT from the test recorder/reproducer and replace it with the sample tape under test. Using the applicable record conditions specified in subparagraph 5.3.1, Standard Record Conditions, simultaneously record and reproduce the required tracks over the working length of the tape.

5.3.11.2 Check the reproduce output signals for all decreases in level that equal or exceed 6 dB for a period of 5 microseconds for high energy and high resolution tape or 10 microseconds for standard resolution tape. When the dropout time period exceeds the specified time, register a dropout count for each sequential time period occurring in the given dropout. The dropout detector electronics determines the 6 dB threshold by means equivalent to a full-wave peak detector circuit.

5.3.11.3 The tape has failed the test when the number of dropout time periods per track per 30.48 m (100 ft) exceeds the limits specified by the procuring agency.

5.3.12 Durability.

5.3.12.1 While using the MSCT and referring to its associated calibration factor, adjust the test recorder/reproducer on all tape tracks for the appropriate MCT bias and record level and optimize the reproduce equalization. Remove the MSCT from the test recorder/reproducer and replace it with the sample tape under test.

5.3.12.2 Using the applicable record conditions specified in subparagraph 5.3.1, Standard Record Conditions, record and reproduce seven tracks simultaneously over the working length of the tape under test. The first 10 test passes are simultaneous record/reproduce passes with tape path cleaning performed at the beginning of each pass. Individually analyze the seven output

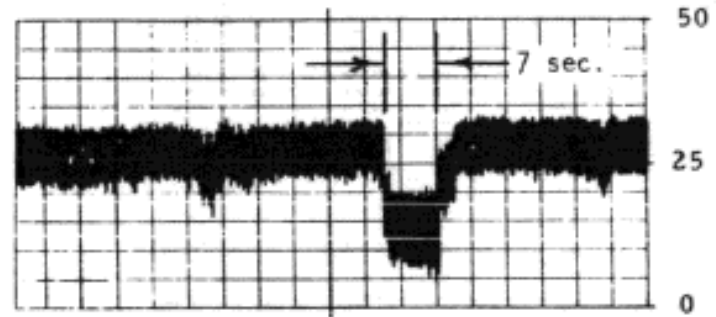
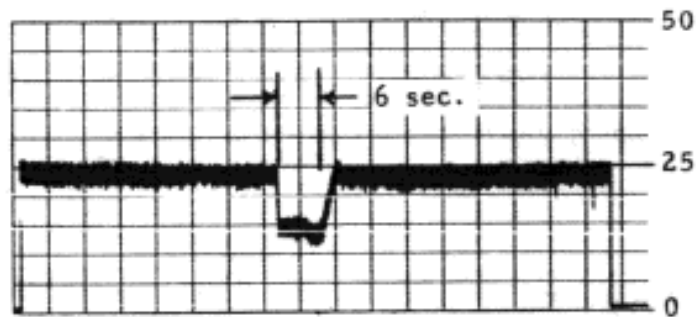

$$\text{Signal Loss}_{\text{dB}} = 20 \log_{10} \frac{\text{Peak Value Before Loss}}{\text{Peak Value During Loss}}$$

$$\begin{aligned} \text{Signal Loss} &= 20 \log_{10} \frac{(25 \text{ div.})}{(16 \text{ div.})} \\ &= 3,9 \text{ dB for 6 sec.} \end{aligned}$$

$$\begin{aligned} \text{Signal Loss} &= 20 \log_{10} \frac{(32,5 \text{ div.})}{(20,0 \text{ div.})} \\ &= 4,2 \text{ dB for 7 sec.} \end{aligned}$$

Figure 5-2. Durability test analysis (see tests 5.3.1.1).

signals for signal loss as defined in subparagraph 7.6.7, Durability, Chapter 7, IRIG Standard 106, using a suitable means of detecting and recording the magnitude and length of the signal losses as described in subparagraph 5.3.3, Level Detector and Recorder, this volume (see Figure 5-2). The tape has failed the test if signal losses in excess of those limits specified by the procuring agency occur per tape pass.

5.3.12.3 At the successful completion of the 10th record/reproduce pass, the remainder of the durability test is accomplished by selecting a 152.4-m (500-ft) section with no previously recorded signal losses from the above tested tape. This tape is cycled for an additional 25 reproduce-only passes. Cleaning the tape path during this portion of the test is not allowed. The tape has failed the accelerated portion of the durability test if 5 or more signal losses, as defined in subparagraph 7.6.7, Durability, Chapter 7, IRIG Standard 106, occur during the 25 passes.

5.3.12.4 In the event that a tape test indicated failure of the durability requirement, immediately stop the recorder, clean the tape path, and continue the test momentarily to demonstrate that signal loss was not due to changes in electronics or head windings.

5.3.13 Modulation Noise. While using the MSCT and referring to its associated calibration factor, adjust the test recorder/reproducer on one or more center tape tracks for the appropriate MCT bias and record level and optimize the reproduce equalization on all test tracks. Remove the MCST from the test recorder/reproducer and replace it with the sample tape under test. Record and reproduce a 400-kHz signal at 3048-mm/s (120-ips) tape speed (7.62 m (0.3-mil) wavelength) throughout the working tape length. Pass the output of the test track through an electronic band-pass filter adjusted for 5 and 500 kHz limits and connect it to the vertical input of an oscilloscope fitted with a suitable camera to record the CRT display. While using an oscilloscope vertical gain of approximately 0.5 v/cm, adjust the reproduced output signal to a level that provides the maximum oscilloscope display. The vertical gain of the oscilloscope is then changed to a sensitivity of 10 times the previous setting, and the vertical center control is adjusted to display the positive peaks of the 400-kHz signal. The sweep of the oscilloscope is changed to "Single Sweep," and the camera lens is opened and single sweep pictures are randomly taken throughout the working tape length. The modulation noise envelope superimposed on the peaks of the 400-kHz signal, excluding large negative excursions caused by dropouts, can be measured directly from the calibrated oscilloscope pictures. The tape has failed the test if the modulation noise envelope, present at any point in the working tape length exceeds the modulation noise limits specified by the procuring agency.

5.3.14 Layer-to-Layer Signal Transfer.

5.3.14.1 Externally erase the sample tape to be tested and place it on the test recorder/reproducer. Using the appropriate bias level, but no input signal, record 10 layers of tape and wind on a 114.3-mm (4-1/2-inch) diameter reel hub at 381-mm/s (15-ips) tape speed. Increase the record level to the maximum level obtainable with the test recorder/reproducer and record a 1.0-kHz signal on one additional layer of tape that is wound on the reel hub. Wind 10

additional layers of tape recorded with bias only over the recorded portion of the tape to maintain intimate contact between the layers under test. Condition the reel of tape at a temperature of 324.9 K (125¹ F) dry heat for a period of four hours. After a stabilization period of four hours at room temperature, play the tape back with the output of the reproduce amplifier connected to the input of a 1 kHz filter with a maximum band pass of 50 Hz. Measure and record the level of the recorded signal and the level of the signal resulting from layer-to-layer signal transfer using equipment with sufficient dynamic range to measure the expected change in signal level. For ease of measuring and analyzing results, a recording wave analyzer is suggested.

5.3.14.2 The tape has failed the test if the difference in signal levels is less than the limits specified by the procuring agency for layer-to-layer signal transfer.¹¹

5.3.15 Ease of Erasure.

5.3.15.1 Externally erase the sample tape to be tested and place it on the test recorder/reproducer. Using the appropriate bias, record a 60-kHz signal at 1524-mm/s (60-ips) tape speed using the maximum record level obtainable with the test recorder/reproducer. Reproduce the tape at a convenient reproduce level with the output connected to a 60-kHz filter having a maximum passband of 1 kHz. Measure the voltage across an appropriate termination at the output of the filter. Pass the sample tape through a 60 Hz ac field of 79.58 kA/M (1000 oersteds) peak value for SR, HR, and HDD tape of 159.16 kA/m (2000 oersteds) peak value for HE tape. Reproduce the tape using the identical test setup and the same reproduce output level setting as described earlier. The voltage measured at the output of the filter is the residual signal. The difference between the recorded signal level and the residual signal level, expressed in dBs, is the effective reduction in signal or erasure.

5.3.15.2 The tape has failed the test if the difference in signal levels is less than the limits specified by the procuring agency for ease of erasure.

5.3.16 Physical Characteristics.

5.3.16.1 Physical characteristics for a new tape should be in accordance with MML 350 Oe and 750 Oe.

5.3.16.2 The tape shall be supplied wound on reels and hubs in accordance with Federal Specification W-R-175, Reels and Hubs for Magnetic Tape, General Specification for and applicable detailed specifications for the application.

5.4 Digital Cassette Tape

This section describes the test procedures to be used in measuring the digital cassette tape performance requirements.

¹¹ A table of suggested tape requirement limits appears in Chapter 7 of IRIG Standard 106.

5.4.1 Standard Record/Reproduce Conditions. Standard record signal is a sinusoidal signal with an amplitude of 700 mV peak-to-peak for 19-mm systems and a sinusoidal signal with an amplitude of 172.5 mV peak-to-peak for 12.65-mm systems.

Standard output level is the average of the peak detected reproduced signal level of a standard record signal recorded the length of the MCT.

Average output signal level is defined as the average (over 1 second) of the peak detected reproduced signal level of a previously recorded standard record signal. The output of the reproduce head shall be peak detected and sampled at a rate of 1 every 200 *usec* for 19-mm systems and 833 *usec* for 12.65-mm systems.

5.4.2 Bit Error Rate Test.

5.4.2.1 General. This test determines the BER performance of the digital cassette tape. The test is conducted at the maximum recommended packing density of the system with the Error Detection and Correction (EDAC) disabled.

5.4.2.2 Test Equipment. Bit Error Rate Test Set - A test set that generates pseudo-random bit sequences at bit rates up to the maximum bit rate of the system under test and measures the resulting bit error rate. The output of the test set shall be 8-bit parallel, byte serial format with a clock signal at the required byte rate for the 19-mm systems and 8- or 16-bit parallel or bit serial for the ½-inch systems. Bit errors shall be displayed as the cumulative bit total. A bit error rate test set with the capability to identify the location of the error bursts is desirable for some applications.

5.4.2.3 Procedure.

5.4.2.3.1 Connect the test set generator output to the input of the tape recorder system under test and the tape recorder output to the test set receiver section.

5.4.2.3.2 Set the test set to pseudo-random bit sequence PRN-23 ($2^{23} - 1$ length) at a bit rate that results in the maximum packing density of the recorder under test. Check the recorder with the tape out of the loop (E to E mode) to verify proper operation of the electronics. Record the signal for the entire length of the tape.

5.4.2.3.3 Rewind the tape and measure the bit error rate as the tape is being reproduced.

5.4.2.4 Data Reduction. Record the cumulative total bit error rate readings and verify that the tape meets specifications. Record the location of error bursts if applicable.

5.4.3 Sensitivity.

5.4.3.1 Purpose. Verify the average output level at any point along the length of the tape does not vary from the standard output level of the MCT by more than the specified value.

5.4.3.2 Procedure. Record a 1/10 upper bandedge standard record signal for a minimum of 15 seconds sequentially on the tape under test and the MSCT.

5.4.3.3 Data Reduction. The sensitivity of the tape shall be established by comparing the average output level of the tape under test with the standard output level of the MCT.

5.4.4 Signal-to-Noise Ratio (SNR).

5.4.4.1 Purpose. Verify that the SNR at any point along the length of the tape is not less than the value when using the MCT. The SNR is defined as the ratio of the composite output signal level of the standard record signal measured from all heads to the composite output level without any signal input.

5.4.4.2 Procedure. Record a 1/10 upper bandedge standard record signal for a minimum of 30 seconds. Remove the input and substitute a short circuit. Record for 30 seconds with no input. Reproduce the tape and note the composite output level in the recorded section of the tape. Continue reproducing the tape and note the composite output level in the section of tape with no input signal present. Repeat at other arbitrary locations over the entire length of the tape. Repeat this procedure using the MCT.

5.4.4.3 Data Reduction. Calculate the SNRs of the tape under test and the MCT. The SNR of the tape under test shall be no lower than the minimum SNR of the MCT.

INDEX OF TESTS

<u>Test</u>	<u>Page</u>
Basic Serial HDDR Test (1) and (2).....	2-39
Bias Leakage Test (1).	1-23
Bias, Record Level and Second Harmonic Distortion Tests (1) and (2).	1-17
Bit Error Rate (BER) Test (1) and (2)	3-2
Bit Error Rate Test (1) and (2).....	4-1
Bit Error Rate Test.....	5-17
Calibration Tape (1).....	3-1
Crosstalk Test (1).....	1-22
Delay Measurements (1).....	4-1
Deviation, Center Frequency And Polarity Tests (1) and (2).....	1-30
Direct Record System Tests.....	1-17
Distortion Test (1) and (2).	1-32
Drift (dc) at Center Frequency Test (1).	1-35
Eye Pattern (1)	3-3
Eye Pattern (1).	1-26
Flutter Measurement Test (1) and (2).	1-7
FM System Tests.....	1-30
Format Verification Test (1).....	4-5
Frequency Response (Direct Recording) Test (1) and (2).....	1-18
Frequency Response Test (1) and (2).	1-31
Head Electrical Polarity and Mechanical Alignment Tests	1-1
Head Polarity Tests (1)	1-1
Interchannel Time Displacement Error Test (1) and (2).....	1-14
Intermodulation Distortion Test (1).....	1-20
Linearity Tests (Dc) (1).	1-34
Longitudinal Track Tests (1) and (2).....	3-4
Longitudinally-Oriented Oxide Instrumentation Magnetic Tape	5-8
Multispeed Record Level Test (1).	1-24
Multispeed Reproduce Transfer Levels Test (1).	1-36
Polarity Test (1)	3-3
Record Head-Stack Azimuth Alignment (1).....	1-2
Record Transfer Characteristic Test (1).....	1-25
Reproduce Head-Stack Azimuth Allignment (1) and (2)	1-4
Sensitivity	5-17
Serial HDDR PCM Bit Synchronizer Test (1).....	2-52
Short Wavelength Instantaneous Non-Uniformity (Dropout).	5-13
Short Wavelength Output Uniformity	5-11
Signal-to-Noise Ratio (SNR).	5-18
Signal-to-Noise Ratio Margin Test (Using Additive Noise) (1).....	2-46
Signal-to-Noise Ratio Margin Test (Using Input Attenuator) (1)	2-43
Signal-To-Noise Ratio Test (1) and (2).	1-32
Signal-to-Noise Ratio Tests	1-19

Speed Ratio Test (1).....	2-41
Speed Variation and Timing Error Tests	1-7
Spurious Component Test (1).....	1-33
Tape Speed Tests	1-5
Time Base Error Test (1) and (2).....	1-11
Time Scaled Playback Test (1) and (2).....	3-3
Wavelength Response and Output at 0.1 Upper Band Edge Wavelengths.....	5-10