



**TEST METHODS FOR TELEMETRY SYSTEMS AND SUBSYSTEMS  
VOLUME II  
TEST METHODS FOR TELEMETRY RADIO FREQUENCY (RF)  
SUBSYSTEMS**

**ABERDEEN TEST CENTER  
DUGWAY PROVING GROUND  
ELECTRONIC PROVING GROUND  
REAGAN TEST SITE  
REDSTONE TEST CENTER  
WHITE SANDS TEST CENTER  
YUMA PROVING GROUND**

**NAVAL AIR WARFARE CENTER AIRCRAFT DIVISION PATUXENT RIVER  
NAVAL AIR WARFARE CENTER WEAPONS DIVISION CHINA LAKE  
NAVAL AIR WARFARE CENTER WEAPONS DIVISION POINT MUGU  
NAVAL SURFACE WARFARE CENTER DAHLGREN DIVISION  
NAVAL UNDERSEA WARFARE CENTER DIVISION KEYPORT  
NAVAL UNDERSEA WARFARE CENTER DIVISION NEWPORT  
PACIFIC MISSILE RANGE FACILITY**

**96TH TEST WING  
412TH TEST WING  
ARNOLD ENGINEERING DEVELOPMENT COMPLEX**

**SPACE LAUNCH DELTA 30  
SPACE LAUNCH DELTA 45**

**NATIONAL AERONAUTICS AND SPACE ADMINISTRATION**

**DISTRIBUTION A: APPROVED FOR PUBLIC RELEASE  
DISTRIBUTION IS UNLIMITED**

This page intentionally left blank.

**DOCUMENT 118-22**

**TEST METHODS FOR TELEMETRY  
SYSTEMS AND SUBSYSTEMS**

**VOLUME 2 Release 2**

**TEST METHODS FOR TELEMETRY  
RADIO FREQUENCY (RF) SUBSYSTEMS**

**October 2022**

**Prepared by**

**TELEMETRY GROUP  
RANGE COMMANDERS COUNCIL**

**Published by**

**Secretariat  
Range Commanders Council  
U.S. Army White Sands Missile Range  
New Mexico 88002**

This page intentionally left blank.

## Table of Contents

<b>Preface</b> .....	<b>xv</b>
<b>Acronyms and Initialisms</b> .....	<b>xvii</b>
<b>Introduction</b> .....	<b>xix</b>
<b>Chapter 1. Test Procedures for Telemetry Antenna Systems</b> .....	<b>1-1</b>
<b>1. General</b> .....	<b>1-1</b>
1.1. TEST: Rate Loop .....	1-2
1.2. TEST: Position Loop Calibration .....	1-5
1.3. TEST: Position Loop .....	1-8
1.4. TEST: Velocity and Acceleration Measurement: Strip Chart Recorder.....	1-11
1.5. TEST: Tracking Error Voltage Gradient .....	1-15
1.6. TEST: Dynamic Tracking Accuracy .....	1-19
1.7. TEST: Antenna Bore sight.....	1-22
1.8. TEST: Antenna Gain.....	1-24
1.9. TEST: Antenna Pattern Test.....	1-29
1.10. TEST: Feed Assembly Unit.....	1-30
1.11. TEST: Solar Calibration using Linear Receiver Method.....	1-33
1.12. TEST: Solar Calibration using Attenuator Method .....	1-38
1.13. TEST: Pedestal Motion Testing.....	1-41
<b>Chapter 2. Test Procedures for Telemetry RF Preamplifiers</b> .....	<b>2-1</b>
<b>2. General</b> .....	<b>2-1</b>
2.1. TEST: Amplifier Gain Compression .....	2-1
2.2. TEST: Bandwidth and Small-signal Power Gain .....	2-5
2.3. TEST: Amplifier IM Products and Intercept Point.....	2-8
2.4. TEST: Amplifier VSWR by Return Loss Method.....	2-14
2.5. TEST: Noise Figure using Automatic Noise Figure Meter .....	2-17
2.6. TEST: Impedance Mismatch .....	2-20
<b>Chapter 3. Test Procedures for Telemetry Multicouplers</b> .....	<b>3-1</b>
<b>3. General</b> .....	<b>3-1</b>
3.1. TEST: Multicoupler Gain Compression .....	3-1
3.2. TEST: Bandwidth and Small-signal Power Gain .....	3-4
3.3. TEST: Multicoupler IM Products and Intercept Point.....	3-7
3.4. TEST: Multicoupler VSWR by Return Loss Method.....	3-14
3.5. TEST: Noise Figure .....	3-18
3.6. TEST: Output Isolation.....	3-22
<b>Chapter 4. Test Procedures for Telemetry Receivers</b> .....	<b>4-1</b>
<b>4. General</b> .....	<b>4-1</b>
4.1. TEST: Spurious Signal Response .....	4-2
4.2. TEST: Noise Figure .....	4-6
4.3. TEST: IF SNR Linearity Test.....	4-8

4.4.	TEST: AGC Static .....	4-10
4.5.	TEST: AGC Dynamic Test - Response to Square Wave.....	4-13
4.6.	TEST: AGC Dynamic Test - Response to Sine Wave.....	4-18
4.7.	TEST: FM Capture Ratio.....	4-21
4.8.	TEST: NPR.....	4-24
4.9.	TEST: Local Oscillator Radiation at RF Input .....	4-30
4.10.	TEST: Local Oscillator Stability .....	4-32
4.11.	TEST: Pulse Code Modulation Bit Error Rate .....	4-36
4.12.	TEST: Frequency Modulation Step Response.....	4-39
4.13.	TEST: Receiver Band Pass Frequency Response using Unmodulated Signal .....	4-41
4.14.	TEST: Receiver Band Pass Frequency Response using Phase-Modulated Signal .....	4-45
4.15.	TEST: Receiver Band Pass Frequency Response using White-noise Input .....	4-49
4.16.	TEST: Data Frequency Response .....	4-51
4.17.	TEST: Automatic Gain Control Stability .....	4-54
4.18.	TEST: Receiver Video Spurious Outputs .....	4-56
4.19.	TEST: Pre-detection Carrier Output .....	4-59
4.20.	TEST: FM Receiver DC Linearity and Deviation Sensitivity .....	4-61
4.21.	TEST: Receiver Phase Noise .....	4-65
4.22.	TEST: Receiver Adjacent Channel Interference.....	4-68
<b>Chapter 5. Test Procedures for Diversity Combiners .....</b>		<b>5-1</b>
<b>5.</b>	<b>General.....</b>	<b>5-1</b>
5.1.	TEST: Diversity Combiner Static Evaluation with Equal RF Signal Strengths .....	5-2
5.2.	TEST: Diversity Combiner Static Evaluation with Unequal RF Signal Strengths .....	5-7
5.3.	TEST: Diversity Combiner Dynamic Evaluation with In-Phase Fading and Equal RF Signal Strengths .....	5-10
5.4.	TEST: Diversity Combiner Dynamic Evaluation with Periodic In-Phase Fading and Unequal RF Signal Strengths.....	5-15
5.5.	TEST: Diversity Combiner Dynamic Evaluation with Periodic Out-of-phase Fading and Equal RF Signal Strengths .....	5-18
5.6.	TEST: Diversity Combiner Dynamic Evaluation with Periodic Out-of-Phase Fading and Unequal RF Signal Strengths.....	5-20
5.7.	TEST: Diversity Combiner Break Frequency.....	5-23
5.8.	TEST: Diversity Combiner Evaluation with Random Fading.....	5-25
5.9.	TEST: Pre-detection Combiner Band Pass Frequency Response using Phase- Modulated Signal.....	5-27
5.10.	TEST: Pre-detection Combiner Band Pass Frequency Response using Unmodulated Signal.....	5-30
5.11.	TEST: Combiner Data Frequency Response .....	5-33
5.12.	TEST: Combiner Pre-detection Carrier Output .....	5-36
<b>Chapter 6. Test Procedures for Telemetry Downconverters .....</b>		<b>6-1</b>
<b>6.</b>	<b>General.....</b>	<b>6-1</b>
6.1.	TEST: Gain Compression and Saturation Level.....	6-1

6.2.	TEST: Bandwidth and Passband Gain Characteristics .....	6-4
6.3.	TEST: Downconverter IM Products and Intercept Point.....	6-7
6.4.	TEST: VSWR .....	6-11
6.5.	TEST: Noise Figure .....	6-14
6.6.	TEST: Channel Isolation.....	6-16
6.7.	TEST: Spurious Signal .....	6-19
6.8.	TEST: Image Rejection.....	6-21
6.9.	TEST: Local Oscillator Frequency Accuracy and Stability .....	6-24
6.10.	TEST: Local Oscillator Radiation at Downconverter Input .....	6-27
<b>Chapter 7. Test Procedures for Telemetry Demodulators .....</b>		<b>7-1</b>
<b>7.</b>	<b>General.....</b>	<b>7-1</b>
7.1.	TEST: Demodulator Bit Error Probability versus $E_b/N_0$ .....	7-1
7.2.	TEST: Reacquisition and Synchronization Loss Thresholds.....	7-5
7.3.	TEST: Bit Rate and Input Frequency Tracking .....	7-7
7.4.	TEST: Demodulator Acquisition Time and Flat Fade Recovery Time. ....	7-9
7.5.	TEST: Demodulator Adjacent Channel Interference Test.....	7-12
7.6.	TEST: PCM/FM Demodulator Modulation Index Sensitivity Test.....	7-15
<b>Chapter 8. Test Procedures for Hardware Implementing Low-Density Parity- Check Codes .....</b>		<b>8-1</b>
<b>8.</b>	<b>General.....</b>	<b>8-1</b>
8.1.	TEST: Receiver/Decoder BEP versus $E_b/N_0$ .....	8-1
8.2.	TEST: Receiver/Decoder Threshold.....	8-7
8.3.	TEST: Receiver/Decoder Initial Acquisition Time and Flat Fade Recovery Time .....	8-10
8.4.	TEST: Receiver/Decoder Latency Time.....	8-14
8.5.	TEST: Receiver/Decoder Adjacent Channel Interference Test .....	8-17
8.6.	TEST: Transmitter/Encoder 99% Occupied Bandwidth and $-25$ -dBm Bandwidth.....	8-20
8.7.	TEST: Transmitter/Encoder Spectral Mask Compliance .....	8-24
8.8.	TEST: LDPC-Enabled Transmitter/Encoder to Receiver/Decoder Interoperability.....	8-27
<b>Chapter 9. Test Procedures for Space-Time Coding Capable Hardware .....</b>		<b>9-1</b>
<b>9.</b>	<b>General.....</b>	<b>9-1</b>
9.1.	TEST: Receiver/Decoder Bit Error Probability Versus $E_b/N_0$ .....	9-1
9.2.	TEST: Receiver/Decoder Reacquisition and Synchronization Loss Thresholds .....	9-10
9.3.	TEST: Receiver/Decoder Acquisition and Flat Fade Recovery Times.....	9-12
9.4.	TEST: Transmitter/Encoder and Receiver/Decoder Data Latency.....	9-16
9.5.	TEST: Demodulator Adjacent Channel Interference Test .....	9-20
9.6.	TEST: Transmitter 99% Occupied Bandwidth and $-25$ dBm bandwidth .....	9-23
9.7.	TEST: Transmitter Spectral Mask Compliance .....	9-27
9.8.	TEST: STC-Enabled Transmitter/Encoder to Receiver/Decoder Interoperability.....	9-30
9.9.	TEST: STC Signals with RF Combining.....	9-32

<b>Chapter 10. Test Procedures for Implementing Multipath Channel Conditions .....</b>	<b>10-1</b>
<b>10. General.....</b>	<b>10-1</b>
10.1. TEST: System Bit Error Rate for Static 3-ray Channels .....	10-5
10.2. TEST: System Bit Error Rate for Static 2-ray Channels .....	10-9
10.3. TEST: Receiver/Equalizer Link Availability for Dynamic Channel 1 .....	10-13
10.4. TEST: System Link Availability for Dynamic Channel 2.....	10-18
<b>Chapter 11. Test Procedures for Assessing Telemetry Receiver Data Quality</b>	
<b>Metrics .....</b>	<b>11-1</b>
<b>11. General.....</b>	<b>11-1</b>
11.1. TEST: BER versus Estimated BEP (DQM) with Additive Noise .....	11-3
11.2. TEST: Estimated BEP (DQM) Step and Dwell Response.....	11-9
11.3. TEST: BER versus Estimated BEP (DQM) with Adjacent Channel Interference .....	11-14
11.4. TEST: BER vs BEP for Static 3-Ray Multipath Channel Conditions .....	11-21
11.5. TEST: BER vs BEP for Static 2-Ray Multipath Channel Conditions .....	11-26
11.6. TEST: DQM (BEP) Resynchronization Response .....	11-31
<b>Appendix A. Intermodulation (IM) Products and Intercept Point.....</b>	<b>A-1</b>
A.1 General .....	A-1
A.2 Intermodulation Products .....	A-1
A.3 Intercept Point.....	A-3
<b>Appendix B. Noise Figure Measurements.....</b>	<b>B-1</b>
B.1 General .....	B-1
B.2 Noise Power .....	B-1
B.3 System Consideration .....	B-1
B.4 Noise Figure Equation .....	B-1
B.5 Noise Figure Measurements .....	B-4
B.6 Measurement Setup.....	B-6
B.7 Measurement Procedure.....	B-7
B.8 Summary .....	B-8
<b>Appendix C. Solar Calibration.....</b>	<b>C-1</b>
C.1 General .....	C-1
C.2 Solar Calibration Technique .....	C-1
C.3 Test for Receiving System Linearity .....	C-4
<b>Appendix D. Citations.....</b>	<b>D-1</b>
<b>Appendix E. References.....</b>	<b>E-1</b>
<b>Appendix F. Index of Tests.....</b>	<b>F-1</b>

### List of Figures

Figure 1. RF/System Measurements and Data Flow Diagram.....	xx
Figure 1-1. Rate Loop Servo Test Block Diagram .....	1-2



Figure 1-2.	Position Loop Calibration Test Setup .....	1-5
Figure 1-3.	Position Loop Servo Test Block Diagram .....	1-8
Figure 1-4.	Strip Chart Recorder Velocity Servo Test Block Diagram.....	1-11
Figure 1-5.	Velocity and Acceleration.....	1-12
Figure 1-6.	Tracking Error Gradient Test Block Diagram .....	1-15
Figure 1-7.	Tracking Error Gradient Linearity Slope for 1 Vdc/Degree .....	1-16
Figure 1-8.	Antenna Gain Measurement Using XY Plotter .....	1-25
Figure 1-9.	Antenna Gain Measurement using a Strip Chart Recorder.....	1-26
Figure 1-10.	Antenna Pattern Measurement Setup.....	1-29
Figure 1-11.	SCM Error Pulses Indicating Minimum Error.....	1-31
Figure 1-12.	SCM Error Signals Indicating Azimuth and Elevation Errors for One Type of SCM Feed .....	1-31
Figure 1-13.	Conical Scan Technique Error and Reference Signals Alignment .....	1-32
Figure 1-14.	Antenna Solar Calibration Using Linear Receiver .....	1-34
Figure 1-15.	Antenna Solar Calibration using Attenuator.....	1-38
Figure 1-16.	Hardware in the Loop Configuration .....	1-41
Figure 1-17.	Antenna Pattern.....	1-42
Figure 1-18.	Detailed System Donfiguration.....	1-44
Figure 1-19.	Converting AM to TDC Reference.....	1-45
Figure 1-20.	Example MIV Position Error .....	1-47
Figure 1-21.	Example MIV Antenna Angular Rates .....	1-47
Figure 1-22.	Example Maximum MIV Antenna Acceleration.....	1-48
Figure 2-1.	Test Setup for Measurement of Amplifier Gain Compression .....	2-2
Figure 2-2.	Amplifier Gain Compression.....	2-3
Figure 2-3.	Test Setup for Measurement of Bandwidth and Small-signal Power Gain .....	2-5
Figure 2-4.	Plot of Power Gain and Bandwidth versus Frequency .....	2-8
Figure 2-5.	Test Setup for Determination of Intercept Point.....	2-8
Figure 2-6.	Typical Display of Fundamental and Third-Order IM Products .....	2-10
Figure 2-7.	Graphical Illustration of Intercept Point .....	2-11
Figure 2-8.	Spurious Response Nomograph.....	2-13
Figure 2-9.	Test Setup for Measurement of Return Loss (VSWR) .....	2-14
Figure 2-10.	Noise Figure using Automatic Noise Figure Meter.....	2-18
Figure 2-11.	Impedance Mismatch Test Setup .....	2-20
Figure 3-1.	Test Setup for Measurement of Multicoupler Gain Compression Level .....	3-1
Figure 3-2.	Multicoupler Gain Compression.....	3-2
Figure 3-3.	Test Setup for Measurement of Bandwidth and Small-signal Power Gain .....	3-4
Figure 3-4.	Plot of Power Gain and Bandwidth versus Frequency .....	3-7
Figure 3-5.	Test Setup for Determination of Intercept Point.....	3-8
Figure 3-6.	Typical Display of Fundamental and Third-Order IM Products .....	3-9
Figure 3-7.	Graphical Illustration of Intercept Point .....	3-10
Figure 3-8.	Spurious Response Nomograph.....	3-11
Figure 3-9.	Test Setup for Measurement of Return Loss (VSWR) .....	3-14
Figure 3-10.	Alternate Test Setup for Measurement of Return Loss (VSWR) .....	3-15
Figure 3-11.	Test Setup for Measurement of Noise Figure .....	3-19
Figure 3-12.	Alternate Test Setup for Measurement of Noise Figure .....	3-19
Figure 3-13.	Output Isolation .....	3-22

Figure 4-1.	Receiver Spurious Signal Response Test.....	4-3
Figure 4-2.	Noise Figure Plot .....	4-6
Figure 4-3.	AGC Static Test .....	4-10
Figure 4-4.	AGC Characteristics and IF Level Control.....	4-11
Figure 4-5.	AGC Response to Square Wave AM.....	4-13
Figure 4-6.	AGC Response to Sine Wave AM.....	4-18
Figure 4-7.	Capture Ratio Test .....	4-21
Figure 4-8.	NPR Standard Test Setup.....	4-25
Figure 4-9.	Curve for Converting NPR and NPRF Data to NPRI.....	4-27
Figure 4-10.	Noise Power Ratio .....	4-28
Figure 4-11.	Local Oscillator Radiation Test .....	4-30
Figure 4-12.	Local Oscillator Stability Test .....	4-32
Figure 4-13.	Receiver PCM Bit Error Rate .....	4-36
Figure 4-14.	Receiver Frequency Modulation Step Response .....	4-39
Figure 4-15.	Receiver Band Pass Response using Unmodulated Signal.....	4-41
Figure 4-16.	Receiver Band Pass Response using Phase-Modulated Signal.....	4-45
Figure 4-17.	Receiver Band Pass Response using White Noise.....	4-49
Figure 4-18.	Receiver Data Frequency Response.....	4-51
Figure 4-19.	Receiver AGC Stability .....	4-54
Figure 4-20.	Receiver Video Spurious Outputs.....	4-56
Figure 4-21.	Receiver Pre-detection Carrier Output.....	4-59
Figure 4-22.	FM Receiver dc Linearity and Deviation Sensitivity .....	4-61
Figure 4-23.	Test Setup for Receiver Phase Noise Test .....	4-65
Figure 4-24.	Test Setup for Adjacent Channel Interference Test.....	4-68
Figure 5-1.	Static Evaluation Test Setup for Diversity Signal Combiner .....	5-2
Figure 5-2.	Dynamic Evaluation Test Setup for Diversity Signal Combiner.....	5-10
Figure 5-3.	Diversity Signal Simulator.....	5-11
Figure 5-4.	Phase-Shifter Modulation and Receiver-AGC Voltage.....	5-12
Figure 5-5.	Combiner Band Pass Response using Phase-Modulated Signal.....	5-27
Figure 5-6.	Combiner Band Pass Response using Unmodulated Signal .....	5-30
Figure 5-7.	Combiner Data Frequency Response.....	5-33
Figure 5-8.	Combiner Pre-detection Carrier Output.....	5-36
Figure 6-1.	Downconverter Gain Compression and Saturation Level Test Setup .....	6-2
Figure 6-2.	Downconverter Bandwidth and Passband Gain Characteristics.....	6-4
Figure 6-3.	Intermodulation Products and Intercept Point Test Setup .....	6-7
Figure 6-4.	Downconverter Intermodulation Products.....	6-8
Figure 6-5.	Downconverter VSWR Test Setup.....	6-11
Figure 6-6.	Downconverter Noise Figure Test Setup.....	6-14
Figure 6-7.	Downconverter Channel Isolation Test Setup .....	6-16
Figure 6-8.	Downconverter Spurious Signal Generation .....	6-19
Figure 6-9.	Image Rejection Test Setup .....	6-21
Figure 6-10.	Local Oscillator Frequency Accuracy and Stability .....	6-24
Figure 6-11.	Local Oscillator Radiation Test .....	6-27
Figure 7-1.	Test Setup for Demodulator BEP Tests .....	7-2
Figure 7-2.	Alternate Setup for Demodulator BEP Test.....	7-2

Figure 7-3.	Test Setup for Demodulator Acquisition Time and Flat Fade Recovery Tests .....	7-9
Figure 7-4.	Test Setup for Adjacent Channel Interference Test .....	7-12
Figure 7-5.	Test Setup for Modulation Index Sensitivity Test .....	7-15
Figure 8-1.	Setup for Step Attenuator/Power Meter BEP Test .....	8-2
Figure 8-2.	Setup for Noise Test Set BEP Test .....	8-3
Figure 8-3.	Setup for Receiver Analyzer BEP Test.....	8-4
Figure 8-4.	Test Setup for Receiver/Decoder Acquisition Time and Flat Fade Recovery Tests.....	8-10
Figure 8-5.	Test Setup for Receiver/Decoder Latency Time Test.....	8-14
Figure 8-6.	Receiver/Decoder Latency Tests .....	8-15
Figure 8-7.	Test Setup for Adjacent Channel Interference Test.....	8-17
Figure 8-8.	OBW Example 5 Mbps SOQPSK-LDPC (4096_4/5) .....	8-20
Figure 8-9.	Test Setup for 99% Occupied Bandwidth and -25-dBm Bandwidth Test .....	8-20
Figure 8-10.	Over-the-Air Test Setup for 99% Occupied Bandwidth and -25-dBm Bandwidth .....	8-21
Figure 8-11.	Spectrum Example for 0-dBc Determination .....	8-22
Figure 8-12.	Test Setup for Spectral Mask Compliance.....	8-24
Figure 8-13.	Test Setup for Interoperability .....	8-27
Figure 9-1.	Setup for Step Attenuator/Power Meter Bit Error Probability Test.....	9-2
Figure 9-2.	Setup for Noise Test Set Bit Error Probability Test .....	9-2
Figure 9-3.	Setup for Receiver Analyzer/VSG Bit Error Probability Test.....	9-3
Figure 9-4.	Test Setup for Receiver/Decoder Acquisition and Flat Fade Recovery .....	9-12
Figure 9-5.	STC Frame .....	9-16
Figure 9-6.	Measuring STC Latency .....	9-16
Figure 9-7.	Mixed Domain Oscilloscope RF Latency (Transmitter) Measurement.....	9-17
Figure 9-8.	Data Latency .....	9-18
Figure 9-9.	Setup for Adjacent Channel Interference Test.....	9-20
Figure 9-10.	OBW Example 5Mbps SOQPSK-STC .....	9-23
Figure 9-11.	Setup for Bandwidth Measurement Test.....	9-24
Figure 9-12.	Modulated, Unmodulated, and Total Power Estimate Waveforms .....	9-25
Figure 9-13.	Spectral Mask Compliance Setup .....	9-27
Figure 9-14.	Transmitter/Encoder to Receiver/Decoder Interoperability Test Setup.....	9-30
Figure 9-15.	Combiner Test Configuration .....	9-32
Figure 10-1.	Setup using Channel Emulator for 3-Ray Static Multipath Test .....	10-5
Figure 10-2.	Setup using Receiver Analyzer for 3-Ray Static Multipath Test.....	10-6
Figure 10-3.	Setup using Discrete RF Components for 3-Ray Static Multipath Test .....	10-6
Figure 10-4.	Setup using Channel Emulator for 2-ray Static Multipath Test.....	10-9
Figure 10-5.	Setup using Receiver Analyzer for 2-ray Static Multipath Test.....	10-10
Figure 10-6.	Setup using Channel Emulator for Dynamic Channel Multipath Test .....	10-13
Figure 10-7.	Setup using Receiver Analyzer for Dynamic Channel Multipath Test.....	10-14
Figure 11-1.	Setup for Step Attenuator/Power Meter for BER versus BEP Test.....	11-4
Figure 11-2.	Setup using Noise Test Set for BER versus BEP Test.....	11-5
Figure 11-3.	Setup using Receiver Analyzer for BER versus BEP Test.....	11-6
Figure 11-4.	Setup for Step and Dwell Testing using Step Attenuator/Power Meter .....	11-9
Figure 11-5.	Setup for Step and Dwell Test using Noise Test Set .....	11-10

Figure 11-6.	Setup for Step and Dwell Test using Receiver Analyzer.....	11-10
Figure 11-7.	Setup for ACI Test using Discrete Components.....	11-15
Figure 11-8.	Setup for ACI Test using Noise and Interference Test Set.....	11-16
Figure 11-9.	Setup for ACI Test using Receiver Analyzer .....	11-16
Figure 11-10.	Setup for Static 3-ray Multipath Channel Conditions using Discrete Components .....	11-22
Figure 11-11.	Setup for Static 3-ray Multipath Channel Conditions using Channel Emulator.....	11-22
Figure 11-12.	Setup for Static 3-ray Multipath Channel Conditions using Receiver Analyzer.....	11-23
Figure 11-13.	Setup for Static 2-ray Multipath Channel Conditions using Channel Emulator.....	11-26
Figure 11-14.	Setup for Static 2-ray Multipath Channel Conditions using Channel Emulator.....	11-27
Figure 11-15.	Setup for Resynchronization Response using Noise Test Set .....	11-32
Figure 11-16.	Setup for Resynchronization Response using Receiver Analyzer.....	11-33
Figure A-1.	Illustration of Spectrum for Two Fundamental Frequencies, F1 and F2, with Second- and Third-Order Response.....	A-3
Figure A-2.	Graphical Representation of Intercept Point.....	A-4
Figure B-1.	Receiving System with Filter before the Preamplifier.....	B-2
Figure B-2.	Receiving System with Filter after Preamplifier .....	B-3
Figure B-3.	Noise Figure Measurement using TM Receiver .....	B-6
Figure B-4.	Noise Figure using Filter, Mixer, and Oscillator .....	B-6
Figure C-1.	Block Diagram for System Linearity Test .....	C-4
Figure C-2.	IF SNR versus Attenuation .....	C-5

### List of Tables

Table 1-1.	Test Matrix for Telemetry Antenna Systems.....	1-1
Table 1-2.	Calibration Test Points.....	1-46
Table 2-1.	Test Matrix for TM RF Preamplifiers.....	2-1
Table 2-2.	Return Loss to Equivalent VSWR .....	2-17
Table 3-1.	Test Matrix for TM Multicouplers.....	3-1
Table 3-2.	Return Loss to Equivalent VSWR .....	3-18
Table 4-1.	Standard Test Conditions.....	4-1
Table 4-2.	Test Matrix for TM Receivers .....	4-1
Table 4-3.	Exceptions to Standard Test Conditions.....	4-25
Table 4-4.	PCM Peak Deviation for Various PCM Codes and Demodulator Types .....	4-36
Table 5-1.	Test Matrix for Diversity Combiners.....	5-1
Table 6-1.	Test Matrix For TM Downconverters.....	6-1
Table 7-1.	Test Matrix for TM Demodulators .....	7-1
Table 8-1.	Test Matrix for LDPC-Enabled TM Hardware.....	8-1
Table 9-1.	Test Matrix for STC-Capable Telemetry Hardware .....	9-1
Table 10-1.	Doppler Frequency Factor .....	10-3
Table 10-2.	Doppler Spread ( $B_{rms}$ ) .....	10-3
Table 10-3.	Test Matrix for System Testing .....	10-4
Table 11-1.	BEP Versus DQM.....	11-1

Table 11-2. Test Matrix for Data Quality Metric Testing ..... 11-2

### List of Data Sheets

<u>DATA SHEET NO.</u>	<u>Page</u>
<b>Chapter 1. Test Procedures for Telemetry Antenna Systems.....</b>	<b>1-1</b>
1-1. Pedestal drive system characteristics: Rate loop test.....	1-4
1-2. Position loop calibration: position loop test servo bandwidth amplifiers.....	1-7
1-3. Pedestal drive system characteristics: position loop test .....	1-10
1-4. Velocity and acceleration measurement: strip chart recorder.....	1-14
1-5. Tracking error voltage gradient .....	1-18
1-6. Dynamic tracking accuracy.....	1-21
1-7. Antenna bore sight test.....	1-23
1-8. Antenna gain test.....	1-28
1-9. Solar calibration using linear receiver method .....	1-37
1-10. Solar calibration using attenuator method .....	1-40
<b>Chapter 2. Test Procedures for Telemetry RF Preamplifiers.....</b>	<b>2-1</b>
2-1. Amplifier gain compression method: power meter measurement .....	2-4
2-2. Bandwidth and small-signal power gain including temperature and supply voltage variations .....	2-7
2-3. Intermodulation products and intercept point .....	2-12
2-4. VSWR by return to loss method including temperature variations .....	2-16
2-5. Noise figure using automatic noise figure meter .....	2-19
2-6. Impedance mismatch .....	2-21
<b>Chapter 3. Test Procedures for Telemetry Multicouplers .....</b>	<b>3-1</b>
3-1. Multicoupler gain compression.....	3-3
3-2. Bandwidth and small-signal power gain including temperature and supply voltage variations .....	3-6
3-3. Intermodulation products and intercept point .....	3-13
3-4. VSWR by return loss method including temperature variations .....	3-17
3-5. Noise figure.....	3-21
3-6. Output isolation.....	3-23
<b>Chapter 4. Test Procedures for Telemetry Receivers.....</b>	<b>4-1</b>
4-1. Spurious signal response.....	4-5
4-2. Noise figure.....	4-7
4-3. IF SNR .....	4-9
4-4. AGC static.....	4-12
4-5. AGC dynamic test - response to square wave .....	4-16
4-6. AGC dynamic test - response to sine wave .....	4-20
4-7. FM capture ratio.....	4-23
4-8. Noise power ratio.....	4-29
4-9. Local oscillator radiation .....	4-31
4-10(1). Local oscillator stability (crystal mode) .....	4-34
4-10(2). Local oscillator stability (VFO mode) .....	4-35

4-11.	Pulse code modulation bit error rate .....	4-38
4-12.	Frequency modulation step response .....	4-40
4-13.	Receiver band pass frequency response using unmodulated signal.....	4-44
4-14.	Receiver band pass frequency response using a phase-modulated signal .....	4-47
4-15.	Receiver band pass frequency response using white-noise input .....	4-50
4-16.	Data frequency response .....	4-53
4-17.	Automatic gain control stability.....	4-55
4-18.	Receiver video spurious outputs .....	4-58
4-19.	Pre-detection carrier output.....	4-60
4-20.	FM receiver dc linearity and deviation sensitivity.....	4-64
4-21.	Receiver phase noise test .....	4-67
4-22.	Adjacent channel interference.....	4-70
<b>Chapter 5.</b>	<b>Test Procedures for Diversity Combiners .....</b>	<b>5-1</b>
5-1.	Static, equal RF signal strength .....	5-6
5-2(1).	Static, unequal RF signal strength .....	5-8
5-2(2).	Static, unequal RF signal strength .....	5-9
5-3.	Dynamic, equal RF signal strength (in-phase fading) .....	5-14
5-4(1).	Dynamic, unequal RF signal strength (in-phase fading) .....	5-16
5-4(2).	Dynamic, unequal RF signal strength (in-phase fading) .....	5-17
5-5.	Dynamic, equal RF signal strength (out-of-phase fading).....	5-19
5-6(1).	Dynamic, unequal RF signal strength (out-of-phase fading).....	5-21
5-6(2).	Dynamic, unequal RF signal strength (out-of-phase fading).....	5-22
5-7.	Dynamic, break frequency .....	5-24
5-8.	Diversity combiner evaluation with random fading .....	5-26
5-9.	Pre-detection combiner band pass frequency response using phase- modulated signal .....	5-29
5-10.	Pre-detection combiner band pass frequency response using unmodulated signal .....	5-32
5-11.	Combiner data frequency response .....	5-35
5-12.	Combiner pre-detection carrier output.....	5-37
<b>Chapter 6.</b>	<b>Test Procedures for Telemetry Downconverters .....</b>	<b>6-1</b>
6-1.	Gain compression and saturation level .....	6-3
6-2.	Bandwidth and passband gain characteristic .....	6-6
6-3.	Intermodulation products and intercept point .....	6-10
6-4.	VSWR.....	6-13
6-5.	Noise figure.....	6-15
6-6.	Channel isolation .....	6-18
6-7.	Spurious signal generation.....	6-20
6-8.	Image rejection.....	6-23
6-9.	Local oscillator frequency accuracy and stability.....	6-26
6-10.	Local oscillator radiation test.....	6-29
<b>Chapter 7.</b>	<b>Test Procedures for Telemetry Demodulators .....</b>	<b>7-1</b>
7-1.	Bit error probability versus $E_b/N_0$ .....	7-4
7-2.	Acquisition and synchronization loss thresholds versus $E_b/N_0$ .....	7-6

7-3.	Bit rate and input frequency tracking.....	7-8
7-4.	Demodulator acquisition time and flat fade recovery time.....	7-11
7-5.	Adjacent channel interference.....	7-14
7-6.	PCM/FM demodulator modulation index sensitivity test.....	7-17
<b>Chapter 8.</b>	<b>Test Procedures for Hardware Implementing Low-Density Parity- Check Codes .....</b>	<b>8-1</b>
8-1.	Bit error probability versus $E_b/N_0$ .....	8-6
8-2.	Threshold $E_b/N_0$ .....	8-9
8-3.	Acquisition time and flat fade recovery time.....	8-13
8-4.	Receiver/decoder latency time .....	8-16
8-5.	Adjacent channel interference.....	8-19
8-6.	99% occupied bandwidth and $-25$ -dBm bandwidth.....	8-23
8-7.	Transmitter spectral mask compliance.....	8-26
8-8.	Transmitter to receiver interoperability .....	8-28
<b>Chapter 9.</b>	<b>Test Procedures for Space-Time Coding Capable Hardware .....</b>	<b>9-1</b>
9-1(A).	Bit error probability versus $E_b/N_0$ with equal S0/S1 signal levels.....	9-6
9-1(B).	Bit error probability versus $E_b/N_0$ with S0 or S1 only .....	9-7
9-1(C).	Bit error probability versus $E_b/N_0$ STC unequal amplitude .....	9-8
9-1(D).	Bit error probability versus $E_b/N_0$ STC unequal delay .....	9-9
9-2.	Receiver/decoder acquisition and synchronization loss thresholds versus $E_b/N_0$ .....	9-11
9-3.	Receiver/decoder acquisition and flat fade recovery times .....	9-15
9-4.	Transmitter/encoder/receiver/decoder data latency .....	9-19
9-5.	Receiver/decoder adjacent channel interference.....	9-22
9-6.	Transmitter 99% occupied bandwidth and $-25$ dBm bandwidth .....	9-26
9-7.	Transmitter/encoder spectral mask compliance.....	9-29
9-8.	Transmitter/encoder to receiver/decoder interoperability.....	9-31
9-9.	STC signals with RF combining.....	9-33
	<b>Test Procedures for Implementing Multipath Channel Conditions .....</b>	<b>10-1</b>
10.1.	Receiver/Equalizer BER for Static 3-ray Channels.....	10-8
10.2.	System Bit Error Rate for Static 2-ray Channels .....	10-12
10.3.	System Link Availability for Dynamic Channel 1 .....	10-17
10.4.	System Link Availability for Dynamic Channel 2 .....	10-19
	<b>Test Procedures for Assessing Telemetry Receiver Data Quality Metrics .....</b>	<b>11-1</b>
11-1.	BER versus BEP with Additive Noise.....	11-8
11-2.	Estimated BEP (DQM) Step and Dwell Response .....	11-13
11.3	BER vs BEP with Adjacent Channel Interference.....	11-19
11.4.	BER vs BEP for Static 3-Ray Multipath Channel Conditions.....	11-25
11-5.	BER vs BEP for Static 2-Ray Multipath Channel Conditions.....	11-30
11-6.	DQM (BEP) Resynchronization Response.....	11-36

This page intentionally left blank.



## Preface

The intent of this document is to provide commonality for testing methodology of all DoD and National Aeronautics and Space Administration facilities. Compliance with the test requirements in this document will eliminate confusion of testing requirements among the national test ranges and facilities.

This release of the Range Commanders Council (RCC) Document 118 Volume 2 reflects the efforts undertaken by the RCC Telemetry Group Radio Frequency Systems Committee for completion of Task TG-181.

The new Chapter 11 provides test methods that assess how accurately a telemetry receiver estimates the signal quality, in terms of bit error probably, under several transmission channel conditions.

Please address any questions to:

Secretariat, Range Commanders Council  
ATTN: TEWS-RCC  
1510 Headquarters Avenue  
White Sands Missile Range, New Mexico 88002-5110  
Phone: (575) 678-1107      DSN 258-1107  
Fax: (575) 678-9517      DSN 258-9517  
E-mail: [usarmy.wsmr.attec.list.rcc@mail.mil](mailto:usarmy.wsmr.attec.list.rcc@mail.mil)

This page intentionally left blank.

## Acronyms and Initialisms

ac	alternating current
ACI	adjacent channel interference
ACU	antenna control unit
AGC	automatic gain control
AM	amplitude modulation
ARTM CPM	Advanced Range Telemetry Continuous Phase Modulation
ASM	attached synchronization marker
AWGN	additive white Gaussian noise
Az/EI	azimuth and elevation
BEP	bit error probability
BER	bit error rate
BERT	bit error rate test
†BW	bandwidth
dB	decibel
dBc	decibels relative to the carrier
dB <sub>i</sub>	decibels referenced to isotropic radiator
dB <sub>m</sub>	decibels referenced to one milliwatt
dBV	decibels relative to one volt
dc	direct current
deg	degree
DQE	data quality encapsulation
DQM	data quality metric
ENR	excess noise ratio
FAU	feed assembly unit
FQPSK-JR	Feher-patented Quadrature Phase Shift Keying Jefferis-Rich
<i>G</i>	gain
GHz	gigahertz
<i>G/T</i>	gain/temperature
HWIL	hardware in the loop
Hz	hertz
IF	intermediate frequency
IM	intermodulation
IMU	inertial measurement unit
IP	intercept point
I/Q	in-phase and quadrature
IRIG	Inter-range Instrumentation Group
K	Kelvin
kHz	kilohertz
LDPC	low-density parity-check
†LO	local oscillator
LOS	line of sight
†LT	lost time
m	meter
MATV	maximum azimuth tracking velocity

Mbps	megabits per second
MCM	mid-course maneuver
MDO	mixed-domain oscilloscope
MGC	manual gain control
MHz	megahertz
MIL-STD	Military Standard
mm	millimeter
MRTFB	Major Range and Test Facility Base
ms	millisecond
MSF	maximum instantaneous velocity
†NF	noise figure
NPR	noise power ratio
NPRF	noise power ratio floor
NPRI	noise power ratio intermodulation
ns	nanosecond
OBW	occupied bandwidth
OTA	over the air
PCM	pulse code modulation
PM	phase modulation
p/s	pulse per second
RBW	resolution bandwidth
RCC	Range Commanders Council
RF	radio frequency
rms	root mean square
RTC	real-time controller
SCM	single-channel monopulse
†SES	severely errored second
SOQPSK-TG	Shaped Offset Quadrature Phase Shift Keying, Telemetry Group
SNR	signal-to-noise ratio
STC	space-time coding
SUT	system under test
SWR	standing wave ratio
TDC	top dead center
TED	tracking error demodulator
TG	tachometer gradient
TM	telemetry
VBW	video bandwidth
Vdc	volts direct current
VFO	variable frequency oscillator
VSWR	voltage standing wave ratio
*XTAL	crystal

\* Only in data sheets

† Only in data sheets and equations

## Introduction

The Telemetry Group of the Range Commanders Council (RCC) has prepared this document to provide common methods for testing radio frequency (RF) equipment. [Figure 1](#) is included to serve as a guide for recommended tests to verify equipment status. The use of common methods should minimize problems when organizations exchange test results. Other volumes of this document address test methods for recorder/reproducer systems and magnetic tape, data multiplex equipment, and vehicular telemetry systems. The *Telemetry Standards*<sup>1</sup> and the *Telemetry Applications Handbook*<sup>2</sup> are companion documents.

The test methods in this document provide standard outlines on how to measure various parameters. The comments listed below apply where appropriate.

1. Equipment may need to be tested at a variety of environmental conditions such as temperature, humidity, vibration, and shock. The user needs to determine the appropriate test conditions.
2. Electromagnetic interference characteristics should be measured in accordance with the latest version of Military Standard (MIL-STD)-461, *Requirements for the Control of Electromagnetic Interference Characteristics of Subsystems and Equipment*.<sup>3</sup>
3. Proper interconnection of equipment is critical for accurate test results. Verify that connectors are not corroded or otherwise damaged. Tighten connectors properly. The cables should not be kinked, cut, stretched, or otherwise damaged. The line losses for RF cables should be known prior to their use for correct interpretation of the data results.
4. The test equipment may output spurious signals that produce erroneous test results. Verify that the test equipment is not causing problems with the measurements.
5. The test equipment should have an accuracy of 10 percent of the specified tolerance (or 10 percent of the absolute value to be measured if no tolerance is given). This accuracy may not always be possible. The test equipment must have accuracy equal to or better than the required accuracy of the measurement.
6. Signal levels may have to be increased to get valid readings on instruments that have limited sensitivity. Microwave counters are one example.

---

<sup>1</sup> Range Commanders Council. *Telemetry Standards*. RCC 106-22. May 2022. May be superseded by update. Retrieved 13 May 2022. Available at <https://www.trmc.osd.mil/wiki/x/EoPOBg>.

<sup>2</sup> Range Commanders Council. *Telemetry Applications Handbook*. RCC 119-06. May 2006. May be superseded by update. Retrieved 29 June 2021. Available at <https://www.trmc.osd.mil/wiki/x/h4u8Bg>.

<sup>3</sup> Department of Defense. *Requirements for the Control of Electromagnetic Interference Characteristics of Subsystems and Equipment*. MIL-STD-461G. 11 December 2015. May be superseded by update. Retrieved 28 May 2020. Available at [https://quicksearch.dla.mil/qsDocDetails.aspx?ident\\_number=35789](https://quicksearch.dla.mil/qsDocDetails.aspx?ident_number=35789).

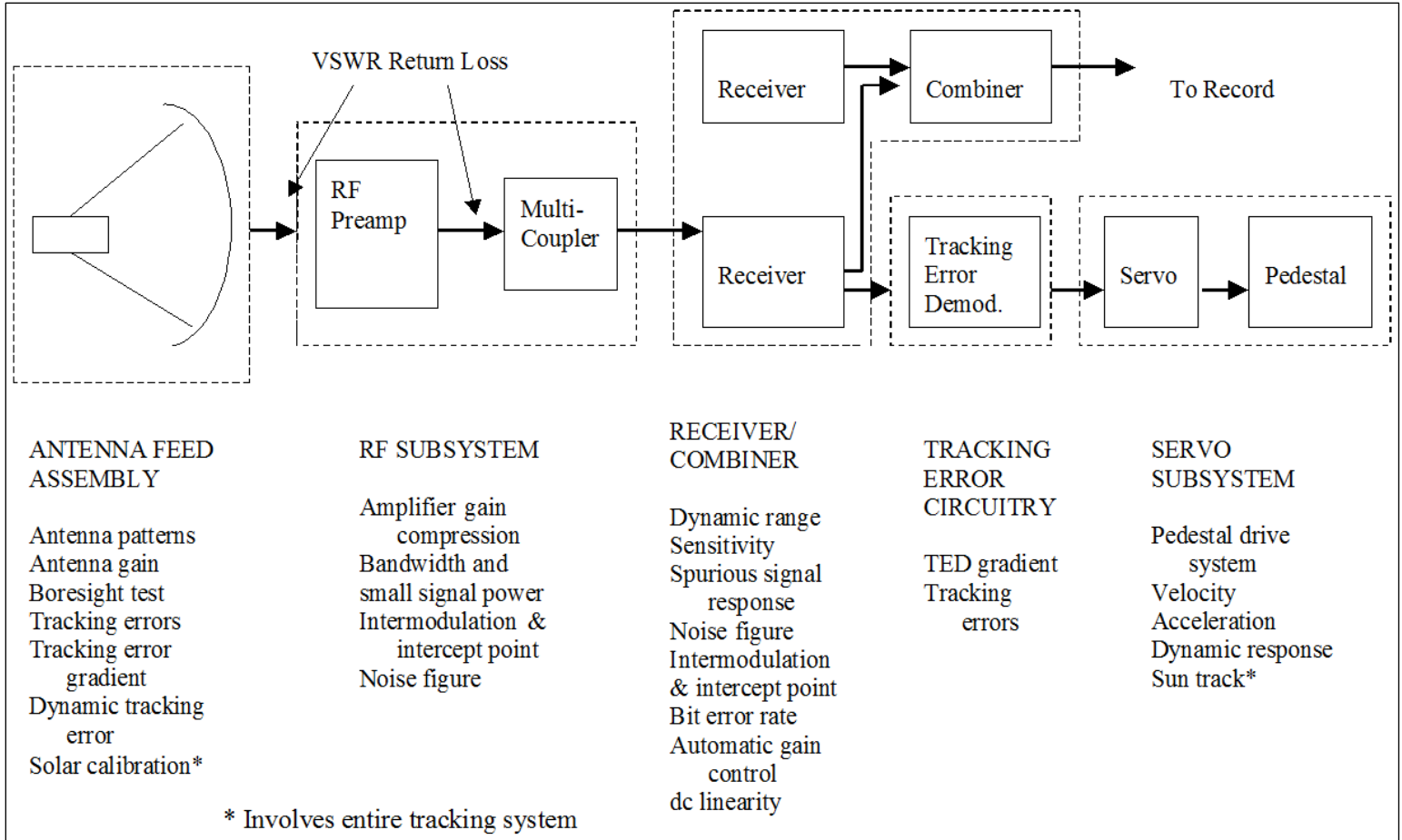

Figure 1. RF/System Measurements and Data Flow Diagram

## CHAPTER 1

### Test Procedures for Telemetry Antenna Systems

#### 1. General

This chapter describes the test procedures used to evaluate the performance of the receiving antenna, the pedestal drive, and the control system. It is assumed that these tests will be performed on an antenna system in the operational configuration. The test procedures are designed to cover a variety of different makes and models of antenna systems.

This series of tests determines the pedestal servo response characteristics used to evaluate the performance of the pedestal drive system. The tests apply to tracking systems that are not computer-controlled. Test method I described in RCC Document 118-89, Test Methods for Telemetry Systems and Subsystems, Volume 2, has been replaced by the rate loop test, calibration test, and position loop tests. The replacement tests facilitate the pedestal velocity measurement by measuring only one parameter (tachometer output voltage) and by obtaining the velocity from an equation. Also, the tests allow the operator to become more aware of the servo subsystem stages. Test method II has been modified to allow the operator to measure acceleration and other servo parameters in the event technical specifications have been lost or are questionable.



Special care must be taken to prevent damage to the electrical and mechanical portions of the pedestal drive system. The procedure for introducing the error drive signal will vary from system to system for this test. The person conducting the test must have sufficient knowledge of the system under test (SUT) to know these methods and positions and to prevent damage to the system.

[Table 1-1](#) lists the types of tests and their test and paragraph number.

<b>Table 1-1. Test Matrix for Telemetry Antenna Systems</b>	
<b>Test Number</b>	<b>Test Description</b>
<a href="#">1.1</a>	Rate loop test
<a href="#">1.2</a>	Position loop calibration test
<a href="#">1.3</a>	Position loop test
<a href="#">1.4</a>	Velocity and acceleration measurement: strip chart recorder test
<a href="#">1.5</a>	Tracking error voltage gradient test
<a href="#">1.6</a>	Dynamic tracking accuracy test
<a href="#">1.7</a>	Antenna bore sight test
<a href="#">1.8</a>	Antenna gain test
<a href="#">1.9</a>	Antenna pattern test
<a href="#">1.10</a>	Feed assembly unit test
<a href="#">1.11</a>	Solar calibration using linear receiver method test
<a href="#">1.12</a>	Solar calibration using attenuator method test

## 1.1. TEST: Rate Loop

1.1.1 Purpose. This test measures the response of the tachometer feedback loop to small and large error inputs. The compensation amplifier, power amplifier, drive motor, tachometer, and gearbox are tested. The pedestal velocity is determined and compared to the theoretical value and to the tracking system specifications for possible system deterioration caused by aging or bad components.

1.1.2 Test Equipment. Multi-channel strip chart recorder (5 milliseconds [ms] rise time maximum), digital voltmeter, or alternating current (ac)/dc voltmeter, variable dc voltage source ranging from at least +20 volts dc to -20 volts dc (Vdc) adjustable to 0.1 volts, and variable dc voltage source ranging up to 100 Vdc.

1.1.3 Test Method. The test method is written for systems with an analog antenna position output.

1.1.4 Setup. Connect the voltage source to the pedestal azimuth servo error input and the voltmeter to the tachometer output as shown in [Figure 1-1](#). Open the position loop output to prevent any unwanted error from being introduced into the rate loop.

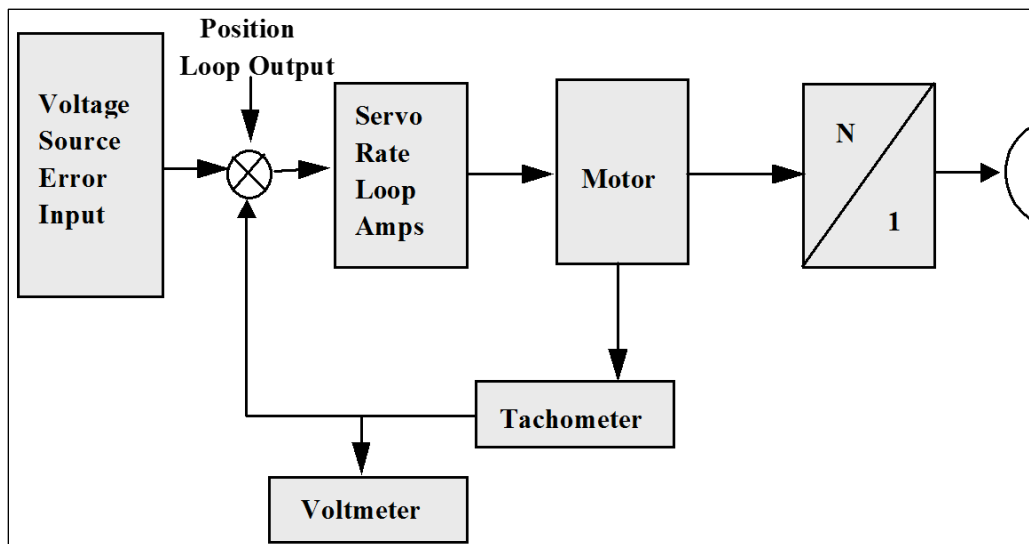



Figure 1-1. Rate Loop Servo Test Block Diagram

### 1.1.5 Procedure

1. Position the antenna pedestal at  $0^\circ$  in azimuth and  $0^\circ$  in elevation. Lock the elevation (Stand-By mode) to allow azimuth rotation only.
2. Disable the auto track input by opening the position loop.

	<b>NOTE</b> In most systems, the following command saturates the input to the servo amplifier loop. Any further increase in the input command has no effect on the pedestal velocity.
---	---

3. Inject a small positive constant voltage at the input to the rate loop (for example, 0.1 Vdc) to prevent saturating the servo amplifier. Note the direction of pedestal rotation (clockwise or



counterclockwise). Allow the antenna pedestal to rotate at least 45°. Inject an identical voltage level of opposite polarity to cause the antenna to rotate in the opposite direction.

4. Measure the maximum tachometer output voltage ( $V_t$ ) with the voltmeter for different input voltages. Repeat step 3 for input voltages tailored to your specific system. (The example for Data Sheet 1-1 and Data Sheet 1-3 shows specific values for a particular system.) The test error voltages should start with small values and increased until the tachometer output voltage can no longer be increased.
5. Use Equation 1-1 to calculate the pedestal velocity for different input voltages. This equation assumes the tachometer gradient (TG) is known from the tracking system servo characteristics.

$$Velocity = \frac{(TG) \cdot V_t \cdot (6 \text{ deg/sec/rpm})}{Gear \text{ ratio}} \quad (\text{Eq. 1-1})$$

Example:

Tachometer gradient = 1000 rpm/20.8 Vdc

Gear ratio = 420:1

1 rpm = 6 deg/sec

Input voltage ( $V_{in}$ ) = 0.5 Vdc

Tachometer output voltage ( $V_t$ ) = 2.495 Vdc (measured value).

$$Velocity = \frac{\frac{1000 \text{ rpm}}{20.8 \text{ Vdc}} \cdot (2.495 \text{ Vdc}) \cdot (6 \text{ deg/sec/rpm})}{420}$$

$$\underline{Velocity=1.7\text{deg/sec}}$$

6. Record the velocity and tachometer output voltage on Data Sheet 1-1 for different voltage inputs. The above tests can be performed for the elevation system if the gear ratio is different or if the elevation system is suspected of having problems. Substitute the “up” direction for clockwise and “down” for counterclockwise.

<b>Data Sheet 1-1. Telemetry Antenna Systems</b>		
<b>Test 1.1</b>	<b>Pedestal drive system characteristics: Rate Loop Test</b>	
<b>Manufacturer:</b>	<b>Model:</b>	<b>Serial No.:</b>
<b>Test Personnel:</b>		<b>Date:</b>
<b>Rate Loop Input Voltage</b> (volts)	<b>Tachometer Output Voltage</b> (volts)	<b>Velocity</b> (deg/sec)
0.1		
0.2		
0.5		
1.0		
2.0		
3.0		
4.0		
5.0		
<b>Tachometer Gradient</b> (Vdc/rpm)		
<b>Gear Ratio (N/1)</b>		
<b>Rotation</b> (clockwise/counterclockwise)		

## 1.2. TEST: Position Loop Calibration

1.2.1 Purpose. The position loop calibration determines the maximum error that the servo acceleration bandwidth amplifiers in the position loop can handle before it saturates. This calibration also tests the synchro demodulator since the induced error is from the synchro circuitry that is used for the manual tracking mode. After performing the position loop calibration, repeat the steps under the rate loop test for the position loop test. This test is recommended if the technical specifications are not available for the position servo bandwidth amplifiers to allow the selection of different acceleration rates.

1.2.2 Test Equipment. Digital voltmeter.

1.2.3 Setup. Disable the pedestal by turning off the pedestal power. Measure the position loop output with the digital voltmeter as shown in [Figure 1-2](#).

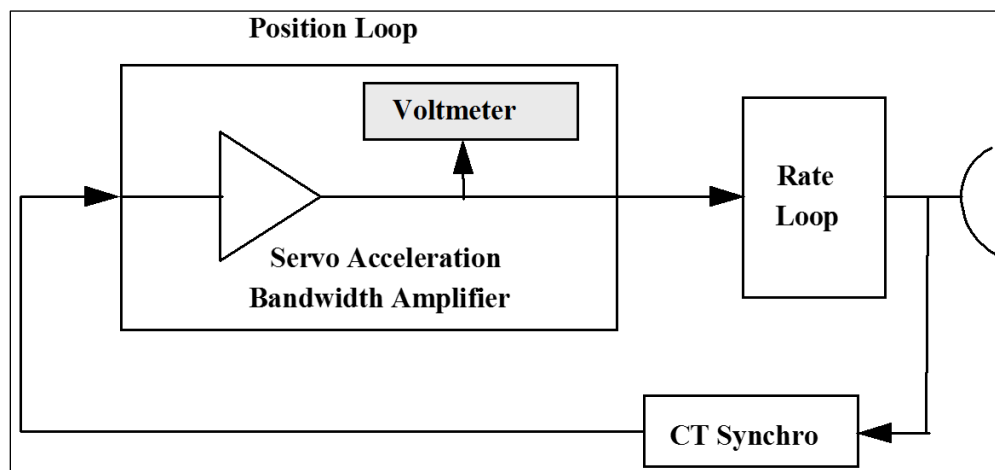

Figure 1-2. Position Loop Calibration Test Setup

### 1.2.4 Procedure

1. Select an angle reference start point on the pedestal. Select a low servo acceleration bandwidth amplifier. If the tracking system has different servo acceleration capabilities, the differences are normally due to different servo bandwidth amplifiers or different amplifier feedback loops. Therefore, calibration process should be repeated for each of them. With the pedestal power off, the offset error is induced from the synchro circuitry by rotating the pedestal in small increments of  $0.1^\circ$ . This rotating action allows the position loop to reach a steady-state condition. If the pedestal power is left on, the pedestal would attempt to null out the error.
2. Manually rotate the pedestal with the pedestal hand crank (or by hand to allow for very slow rotation) from your reference position in  $0.1^\circ$  increments. Use the digital antenna angle readouts (azimuth/elevation) to measure pedestal angle offsets for each  $0.1^\circ$  increment.
3. Use the digital voltmeter and measure the output of the servo bandwidth amplifier. Allow the voltage to settle before recording any values.
4. Repeat the process in  $0.1^\circ$  increments until the measured output voltage no longer increases. The point where the gain does not increase is the saturation point.

5. The saturation point should correspond closely to the maximum error the tracking error demodulator (TED) should output for linear operation of the tracking system. Avoid exceeding the saturation point of the TED.
6. The maximum error voltage at the input to the position loop should not exceed the saturation level obtained from the position loop calibration. The maximum error voltage should be less than the saturation level.

1.2.5 Data Reduction. Enter the position loop calibration data in Data Sheet 1-2.



### 1.3. TEST: Position Loop

1.3.1 **Purpose.** The position loop is the first stage in the servo loop. This test simulates the output of the TED gradient and determines the same parameters as the rate loop test in Subsection 1.2. This test measures the position servo parameters for low, medium, and high acceleration if these features are on the tracking system.

1.3.2 **Setup.** Connect the voltage source to the pedestal azimuth input. Open the TED output to prevent any error from being introduced to the position loop. Connect the voltmeter to the tachometer output as shown in Figure 1-3.

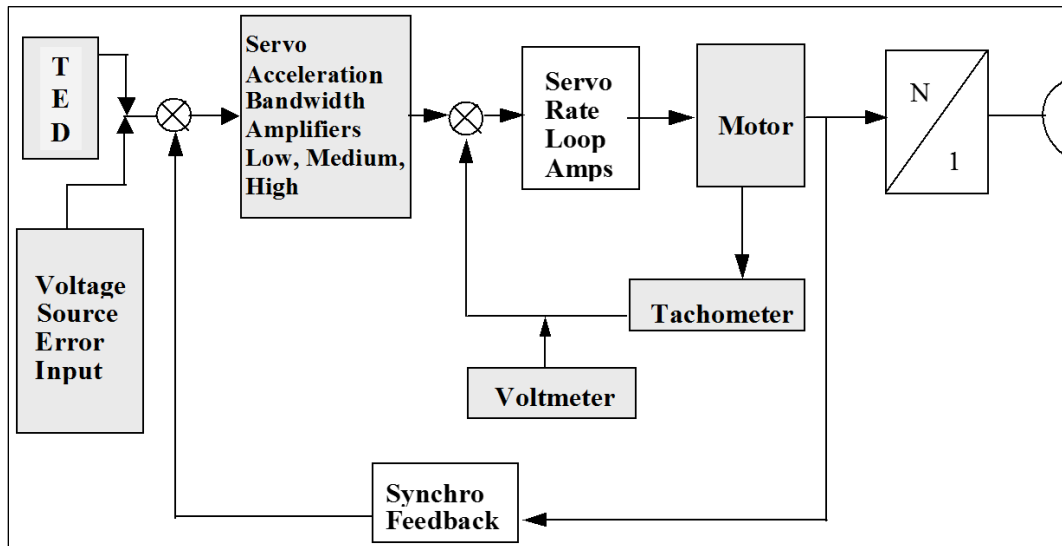
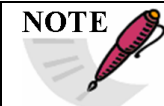

Figure 1-3. Position Loop Servo Test Block Diagram

#### 1.3.3 Procedure

1. Position the antenna pedestal at  $0^\circ$  in azimuth and  $0^\circ$  in elevation. Lock the elevation (STAND-BY mode) to allow azimuth rotation only.

 <p><b>NOTE</b></p>	<p>In most systems, a very large error voltage saturates the input to the servo amplifier loop. Any further increase in the input command has no effect on the pedestal velocity.</p>
--	---

2. Inject a small positive constant voltage (for example, 0.1 Vdc for a 5-V system) to prevent saturating the servo amplifier, at the input to the position loop. This voltage should not exceed the maximum linear value of the TED. Note the direction of pedestal rotation clockwise or counterclockwise. Allow the antenna pedestal to rotate at least  $45^\circ$ . Inject an identical voltage level of opposite polarity to cause the antenna to rotate in the opposite direction.
3. Measure the maximum tachometer output voltage ( $V_t$ ) with the voltmeter for different input voltages. Repeat step 2 for input voltages tailored to your specific system. The test error voltages should start out small and be increased until the tachometer output voltage no longer increases.

4. Use Equation 1-1, repeated here, to calculate the pedestal velocity for different input voltages. This equation assumes the TG is known from the tracking system servo characteristics.

$$Velocity = \frac{(TG) \cdot V_t \cdot (6 \text{ deg/sec/rpm})}{Gear \text{ ratio}} \quad (\text{Eq. 1-1})$$

Example:

$TG = 1000 \text{ rpm}/20.8 \text{ Vdc}$

$\text{Gear ratio} = 420:1$

$1 \text{ rpm} = 6 \text{ deg/sec}$

$\text{Input voltage } (V_{in}) = 0.6 \text{ Vdc}$

$\text{Tachometer output voltage } (V_t) = 87.3 \text{ Vdc}$  (measured value).

$$Velocity = \frac{\frac{1000 \text{ rpm}}{20.8 \text{ Vdc}} \cdot (87.3 \text{ Vdc}) \cdot (6 \text{ deg/sec/rpm})}{420}$$

$$\underline{Velocity = 60 \text{ deg/sec}}$$

5. Record the velocity and tachometer output voltage on Data Sheet 1-3.
6. Position loop input voltages greater than 1 V should not be used unless the TED gradient is linear beyond 1 V.

<b>Data Sheet 1-3. Telemetry Antenna Systems</b>		
<b>Test 1.3</b>	<b>Pedestal drive system characteristics: position loop test</b>	
<b>Manufacturer:</b>	<b>Model:</b>	<b>Serial No.:</b>
<b>Test Personnel:</b>		<b>Date:</b>
<b>Position Loop Input Voltage</b> (volts)	<b>Tachometer Output Voltage</b> (volts)	<b>Velocity</b> (deg/sec)
0.1		
0.2		
0.5		
1.0		
2.0		
3.0		
4.0		
5.0		
<b>Tachometer Gradient</b> (Vdc/rpm)		
<b>Gear Ratio (N/1)</b>		
<b>Rotation</b> (clockwise/counterclockwise)		
<b>Position loop servo bandwidth</b>		
<b>Amplifier</b> (low, medium, high)		



#### 1.4. TEST: Velocity and Acceleration Measurement: Strip Chart Recorder

1.4.1 Purpose. This test measures the pedestal velocity and acceleration using a strip chart recorder.

1.4.2 Setup. Connect the strip chart recorder to the pedestal azimuth outputs as shown in [Figure 1-4](#). Ascertain that the winds are 15 miles per hour (mph) or less to avoid heavy wind torque on the antenna reflector.

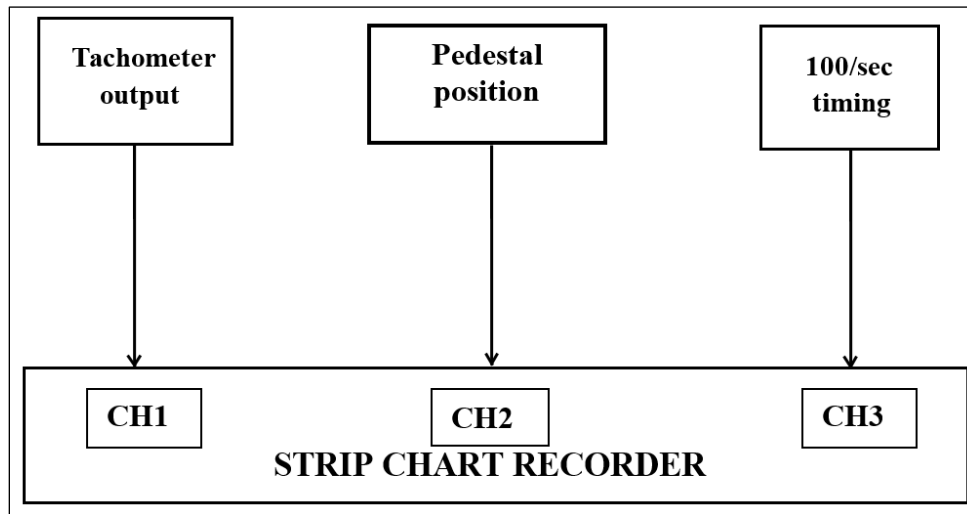
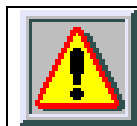

Figure 1-4. Strip Chart Recorder Velocity Servo Test Block Diagram

#### 1.4.3 Procedure

1. Calibrate the strip chart recorder by setting the tachometer output channel at the center of the chart for 0 Vdc. Calibrate the recorder every  $\pm 5$  V up to the maximum voltage determined by the position loop calibration Test.
2. Rotate the pedestal clockwise at the desired input voltage similar to steps 2 and 3 from Subsection [1.3.3](#).
3. Connect a 100 pulse/second (p/s) timing signal to another channel. Adjust the recorder gain for a deflection of 6.25 millimeters (mm) and 12.5 mm.
4. Set the chart speed to 100 mm per second.
5. Start the strip chart recorder. Apply the input voltage as outlined in step 3, Subsection [1.1.5](#).
6. Allow the pedestal to travel at least  $10^\circ$  after the maximum voltage has been reached.
7. Repeat steps 2 to 6 for counterclockwise rotation.
8. Repeat the above steps for elevation, substituting up/down for clockwise/counterclockwise.



Special care must be taken with elevation tests to prevent damage to the antenna and pedestal since the travel limits are less in elevation.

1.4.4 Data Reduction. The strip chart recording of tachometer voltage, position, and timing is used to determine velocity and acceleration of the pedestal drive system.

1. The segment on the strip chart where the tachometer voltage is constant is the maximum constant velocity of the pedestal in that direction (see [Figure 1-5](#)). Mark a segment of constant velocity for  $10^\circ$ . Count the corresponding time interval from the timing channel. The velocity ( $V_\theta$ ) is the angle ( $10^\circ$ ), divided by the time interval (degrees per second) [q/time].

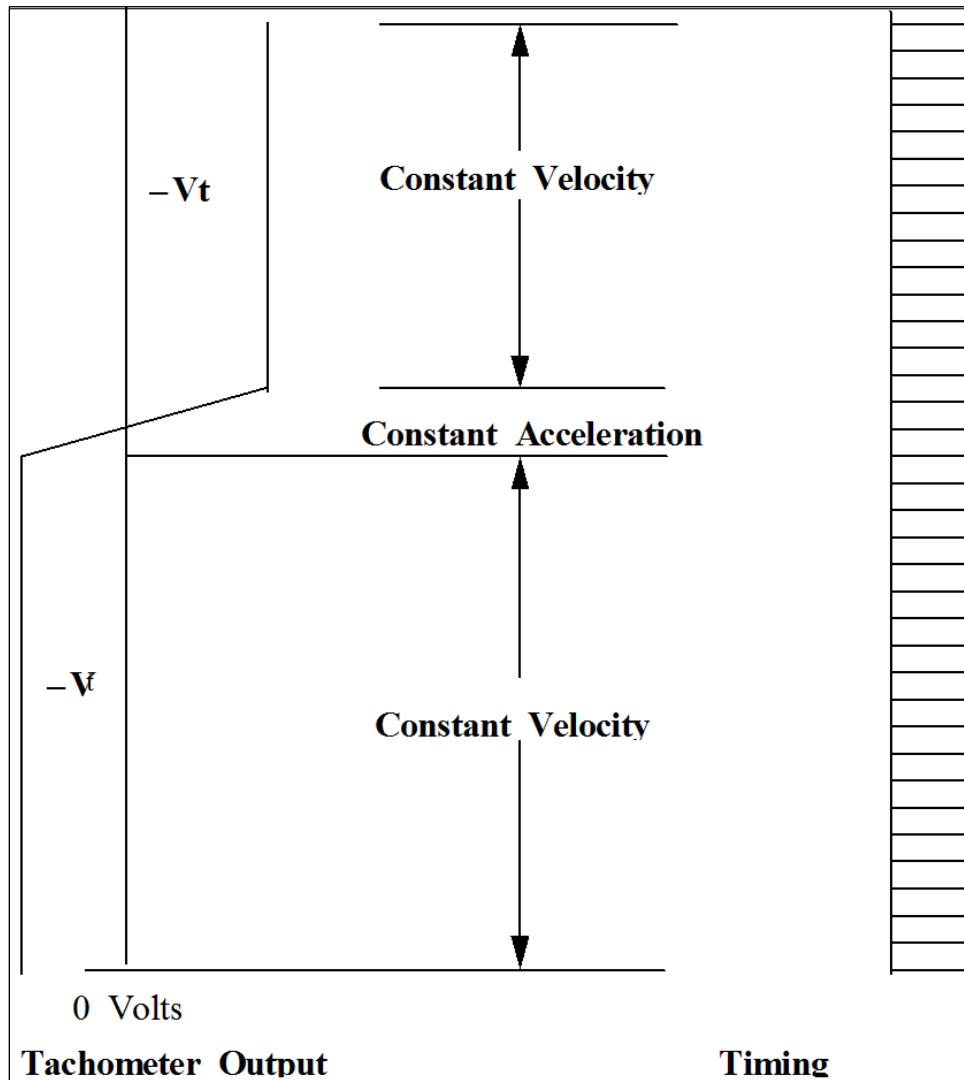



Figure 1-5. Velocity and Acceleration

2. The segment on the strip chart where the tachometer voltage changes from maximum velocity in one direction to maximum velocity in the other direction is the area of maximum acceleration ( $A_\theta$ ) (see [Figure 1-5](#)). This segment typically approaches a straight line.
3. Determine the TG first using Equation 1-2. The TG is found by dividing the tachometer output voltage by the angular velocity corresponding to that output voltage.

$$TG = V_t / V_\theta \quad (\text{Eq. 1-2})$$

<b>NOTE</b> 	The tachometer output voltage and timing marks are for illustration purpose only. They do not correspond to any actual measurements.
---	--

4. Mark a segment of the tachometer voltage change that is linear. From the chart, measure the voltage change marked and the time in which it occurred. Thus, acceleration is the change in tachometer voltage divided by the quantity TG multiplied by the time ( $T_\alpha$ ) as shown in Equation 1-3.

$$A_\theta = \Delta V_t / (TG \cdot T_\alpha) \quad (\text{Eq. 1-3})$$

5. Record the velocity and acceleration parameters on Data Sheet 1-4.

<b>Data Sheet 1-4. Velocity and Acceleration Parameters</b>				
<b>Test 1.4</b>	<b>Velocity and acceleration measurement: strip chart recorder</b>			
	<b>Clockwise</b>	<b>Counter Clockwise</b>	<b>Up</b>	<b>Down</b>
<b>Operational mode</b>				
<b>Tachometer voltage (<math>V_t</math>) volts</b>				
<b>Rotational angle (<math>\theta</math>)</b>				
<b>Rotation time (<math>T_v</math>) sec</b>				
<b>Velocity (<math>V_\theta = \theta/T_v</math>) deg/sec</b>				
<b>Tachometer gradient (<math>V_t/V_\theta</math>)</b>				
<b>Change in tach voltage (<math>\Delta V_t</math>)</b>				
<b>Acceleration time (<math>T_\alpha</math>) sec</b>				
<b>Acceleration (<math>A_\theta = \Delta V_t / TG \cdot T_\alpha</math>) deg/sec<sup>2</sup></b>				

## 1.5. TEST: Tracking Error Voltage Gradient

1.5.1 **Purpose.** This test determines the gradient (error voltage rate of change as a function of degrees offset) of the TED for the azimuth and elevation (Az/El) axes as a function of incoming signal frequency and polarization. The gradient should be linear for the 3-decibel (dB) antenna beam width. The linearity ensures the pedestal drive motors for Az/El will rotate at the correct speed for a given error input. A linear error gradient will allow the antenna to correctly auto track a moving radiating source without losing lock because of antenna lagging or leading the source. This test can also be used to determine the amount of axes crosstalk. In a case where the crosstalk is ten percent or greater, the tracking accuracy may be degraded.

1.5.2 **Test Equipment.** Voltmeter (dc) or oscilloscope set at 0.1 V/division and test range with variable bore sight source for frequency and polarization.

1.5.3 **Test Method.** The test method is written for systems with an analog output.

1.5.4 **Setup.** Ensure that the servo system has been balanced for minimum movement when the system auto track mode is selected. Connect the equipment as shown in [Figure 1-6](#). Ensure the bore sight source antenna is facing the telemetry (TM)-tracking antenna directly.

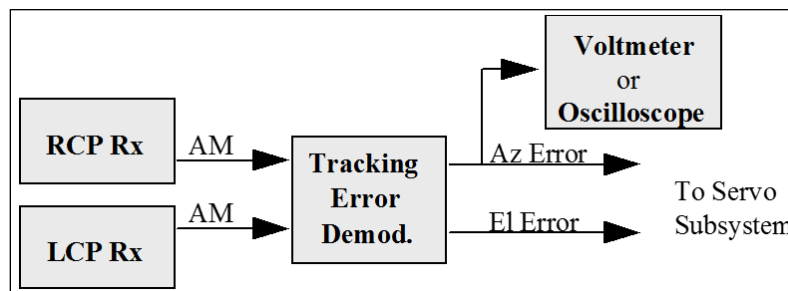



Figure 1-6. Tracking Error Gradient Test Block Diagram

<b>NOTE</b> 	The figure depicts moving the azimuth axis. Measure the elevation (or stationary) axes to obtain the amount of crosstalk.
---	---

1.5.5 **Conditions.** When conducting tests on RF systems, allow sufficient warm-up time to minimize drift in the electronic circuits after the test has started.

1. A test range free of obstructions between the tracking system and the bore sight source is required to eliminate the effects of reflections on the data.
2. The bore sight source should be in the far field and should present an elevation angle of at least twice the antenna 3-dB beam width for the following reasons. First, the effects of ground reflections are reduced, and second, movement of the antenna is permitted downward from the bore sight position.
3. In conducting tests and recording data, it is important for the operator to understand that when the antenna is moved clockwise, the error produced is a counterclockwise error. That is, the error will drive the pedestal counterclockwise back to the bore sight position.

Likewise, a counterclockwise movement produces a clockwise error, an upward movement produces a downward error, and a downward movement produces an upward error.

4. Set the bore sight signal output for a received signal strength at least 20 dB above the receiver threshold.

#### 1.5.6 Procedure

1. Turn the drive system on and rotate the antenna to the bore sight source. Engage the auto track mode and allow the pedestal to null on the bore sight signal. Select “Off” in the elevation axis and “Manual” in the azimuth axis.
2. Ensure that the error signals for both Az/EI are 0 V. No further zeroing of the elevation error signal is required. Use the dc voltmeter (or oscilloscope) to measure the TED output for Az/EI.
3. Record the Az/EI, which will be the reference values for offsetting the antenna. Move the antenna clockwise in small increments; for example, a 3-dB beam width of  $4^\circ$  is  $0.1^\circ$  up to one-half of the 3-dB beam width. Record the angle and the error voltage on the counterclockwise portion of Data Sheet 1-2 for each reading. Also, measure and record the stationary axes voltage at each point. This voltage can be used to determine crosstalk.
4. Repeat step 3 for counterclockwise, up, and down movements.
5. Repeat steps 1 through 4 for each frequency and polarization of interest.

#### 1.5.7 Data Reduction

1. The most useful form of the error gradient data is a graph. Using linear graph paper, plot the antenna offset angle along the abscissa and the corresponding error voltages along the ordinate (see [Figure 1-7](#)). The example at [Figure 1-7](#) is for a system where the 3-dB beam width error gradient is 1 Vdc/deg.

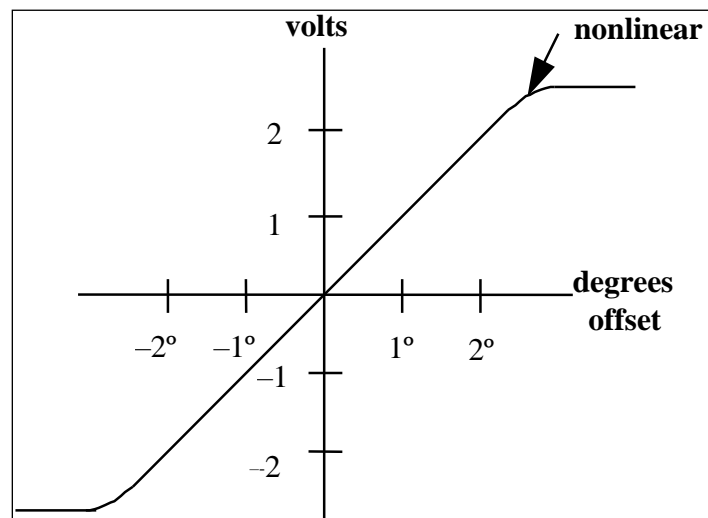

Figure 1-7. Tracking Error Gradient Linearity Slope for 1 Vdc/Degree

2. When this data is combined with the results of Test [1.1](#), an evaluation of antenna tracking error versus pedestal velocity can be performed. This procedure is described in Subsection [1.6](#).
3. The axes crosstalk can be determined by dividing the stationary axis voltage by that of the non-stationary axis voltage for a given offset angle. Multiply the results by 100 to get the amount of crosstalk in percentage.
4. Record the tracking error voltage gradient data on Data Sheet 1-5.

<b>Data Sheet 1-5. Telemetry Antenna Systems</b>				
<b>Test 1.5</b>		<b>Tracking error voltage gradient</b>		
<b>Manufacturer:</b>		<b>Model:</b>		<b>Serial No.:</b>
<b>Test Personnel:</b>				<b>Date:</b>
<b>Error voltage versus off-bore sight angle</b>				
<b>Frequency:</b>				
<b>Polarization:</b>				
<b>Error Voltage (V)</b>				
Off Bore sight Angle (deg) (0.1° increments)	Clockwise	Counter Clockwise	Up	Down
<b>Percent crosstalk</b>				
<b>(Stationary voltage/nonstationary voltage) •100</b>				



## 1.6. TEST: Dynamic Tracking Accuracy

1.6.1 Purpose. This test determines the antenna offset angle produced when tracking in the automatic tracking mode. This offset angle is the tracking error for the given pedestal angular velocity when in the automatic tracking mode. By knowing the maximum tracking error, the measured tracking error can be compared with the calculated value obtained from the system servo error coefficients (or servo constants) such as  $K_p$ ,  $K_v$ , and  $K_a$ . These values define the dynamic tracking rate limits as shown in Equation 1-4.

$$\theta_\epsilon = \frac{\text{position}}{K_p} + \frac{\text{velocity}}{K_v} + \frac{\text{acceleration}}{K_a} \quad (\text{Eq. 1-4})$$

Where:

$K_p$  = Position error coefficient (units in seconds)

$K_v$  = Velocity error coefficient (units in seconds<sup>-1</sup>)

$K_a$  = Acceleration error coefficient (units in seconds<sup>-2</sup>)

$\theta_\epsilon$  = Maximum error that the servo can follow in the auto track mode (units in degrees).

1.6.2 Test Equipment. Variable dc voltage source ranging from  $\pm 20$  Vdc and adjustable to 0.1 V and dc voltmeter.

1.6.3 Setup. Connect the test equipment as described in Subsection [1.3.2](#).

1.6.4 Conditions. Locate the TED input to the servo amplifier loop and make provisions for introducing an external signal from the variable voltage source.

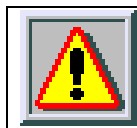

Special care must be taken to prevent damage to the mechanical and electrical portions of the antenna drive system.

### 1.6.5 Procedure

1. Place the antenna drive system for elevation in the “Off” mode. Turn the tracking receiver off.
2. Place the drive for azimuth in the automatic mode with the antenna at 0° for Az/El. The pedestal should not move; if it does, balance the servo amplifier.
3. Starting at 0 Vdc, introduce a positive signal to the input determined in step 3, Subsection [1.1.5](#) that will cause the antenna to move. Movement stops when the signal is removed. Increase the voltage until the maximum pedestal velocity is just reached. Record this voltage.

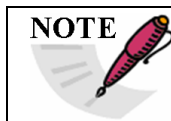

**NOTE** The maximum pedestal velocity is reached when the input drive no longer causes an increase in the tachometer output voltage.

4. Divide the recorded voltage into 5 or 10 steps depending upon the accuracy desired. With the test setup as described in Test [1.4](#), turn the recorder on. Introduce the voltages determined

above, one at a time, and allow the pedestal to reach a constant velocity for at least 10 degrees.

 <b>NOTE</b>	It will probably be necessary to move the antenna back to 0° each time a voltage is introduced.
---	---

5. Change the voltage polarity and repeat steps 1 through 4.
6. Repeat steps 1 through 5 for the elevation axis. For the down movement, start at 90° rather than 0° elevation.

#### 1.6.6 Data Reduction

1. Using step 1 in Subsection [1.4.4](#), determine the velocity for each corresponding voltage introduced. Record this data on Data Sheet 1-6.
2. Plot this data on linear graph paper placing the voltage along the ordinate and the corresponding velocities along the abscissa. A separate graph should be made for Az/El.
3. Combine this data with the results obtained in Subsection [1.5.7](#) to determine the actual tracking error angle for various pedestal velocities.
4. From the graph obtained in data reduction step 2, determine the velocity in question. Find the corresponding drive voltage. On the graph obtained in Subsection [1.5.7](#), locate this voltage on the error voltage ordinate. Locate the corresponding offset angle.
5. This offset angle is the tracking error for the given pedestal angular velocity when in the automatic tracking mode.
6. The velocity for a given offset angle can be determined in a similar manner.

<b>Data Sheet 1-6. Telemetry Antenna Systems</b>				
<b>Test 1.6</b>		<b>Dynamic tracking accuracy</b>		
<b>Manufacturer:</b>		<b>Model:</b>		<b>Serial No.:</b>
<b>Test Personnel:</b>				<b>Date:</b>
<b>Driving Error Voltage</b>		<b>Velocity</b>		
<b>Maximum</b>	<b>Clockwise</b>	<b>Counter Clockwise</b>	<b>Up</b>	<b>Down</b>

## 1.7. TEST: Antenna Bore sight

1.7.1 Purpose. This test determines any variation in the bore sight axis of the antenna and feed assembly unit (FAU) because of changes in frequency, polarization, or time.

1.7.2 Test Equipment. Bore sight source and test range free of obstructions and bore sight source with changeable frequency and polarization.

1.7.3 Setup. Ensure that the demodulator circuits and the servo circuits are properly balanced (minimum drift).

### 1.7.4 Procedure

1. Position the antenna to face the bore sight source. Place the drive system in the automatic tracking mode.
2. Record the Az/EI angles on Data Sheet 1-7. Select the standby mode.
3. Change the bore sight frequency to various frequencies throughout the band of interest. Select the automatic mode and allow the servo to lock on for each frequency selected. Record the corresponding angles.
4. Change between receiver's right circular polarization and left circular polarization while observing at least three frequencies across the band of interest. More frequencies may be necessary to better characterize the antenna. Observe any change in bore sight angles and record the results on Data Sheet 1-7.
5. Allow the drive system to lock on to the bore sight source in the auto track mode. Leave the system in automatic tracking mode for at least 5 minutes while recording peak changes in bore sight angles.

 <b>NOTE</b>	The procedure designed in this step may not be required for all frequencies and polarizations.
---	--

1.7.5 Data Reduction. Variations in the bore sight axis greater than  $0.1^\circ$  could be indicative of a skewed FAU with respect to the reflector.

Data Sheet 1-7. Telemetry Antenna Systems					
Test 1.7		Antenna bore sight test			
Manufacturer:			Model:		Serial No.:
Test Personnel:				Date:	
Frequency	Polarization	Az Angle	(Peak) Az	El Angle	(Peak) El

## 1.8. TEST: Antenna Gain

1.8.1 Purpose. This test verifies the relationship between the antenna reflector and the FAU. The antenna gain is a function of the reflector diameter and frequency of operation. This test is not designed to measure the absolute parameters of the receiving antenna. To measure exact parameters, the antenna must be removed from the tracking system and mounted on a controlled test range. A method for computing the theoretical gain is introduced for a comparison to the measured gain.

1.8.2 Theoretical Antenna Gain. The theoretical antenna gain can be calculated for an antenna having an aperture of 52 percent using Equation 1-5.

$$\text{Gain} = \frac{4\pi A_e}{\lambda^2} \quad (\text{Eq. 1-5})$$

Where:

$A_e$  = Antenna effective area ( $\text{m}^2$ )

$\lambda$  = Wavelength in meters

$\eta_\epsilon$  =  $A_e/A_p$  = aperture efficiency

$A_p$  = Antenna physical area ( $\text{m}^2$ )

Example:

Aperture efficiency ( $\eta_\epsilon$ ) = 52%

Physical area =  $A_p = \pi \cdot (D / 2)^2$

Reflector diameter (D) = 8 ft

$$A_p = \frac{\pi \cdot (8 \cdot 3048)^2}{2^2} = 4.7 \text{ m}^2$$

$$A_e = \eta_\epsilon A_p = 0.52 \cdot 4.7 = 2.444 \text{ m}^2$$

At 2.3 gigahertz (GHz):  $\lambda = 0.13\text{m}$ :

$$\text{Gain} = \frac{4\pi A_e}{\lambda^2} = \frac{4 \cdot \pi \cdot 2.444}{(0.13)^2} = 1817.29$$

$$\text{Gain} = 10 \cdot \log_{10} (1817.29)$$

$$\text{Gain} = 32.59 \text{ dB}$$

1.8.3 Test Equipment. Bore sight source with an unobstructed test range, signal generator to calibrate the XY plotter and the strip chart recorder for the frequencies of interest, standard gain antenna calibrated in the frequency band of interest, tracking receiver, XY plotter, and strip chart recorder.

1.8.4 **Test Method.** Two test methods are recommended for plotting the data. Method 1 uses an XY plotter. Method 2 uses a strip chart recorder. For either method, measure the system noise floor to establish the reference level (amplitude) in dB.

1.8.4.1 **Test Method 1: XY Plotter**

1.8.4.1.1. **Conditions.** Allow the receiver to warm up for a minimum of 30 minutes. Ascertain that no multipath conditions exist.

1.8.4.1.2. **Setup.** Connect the equipment as shown in [Figure 1-8](#).

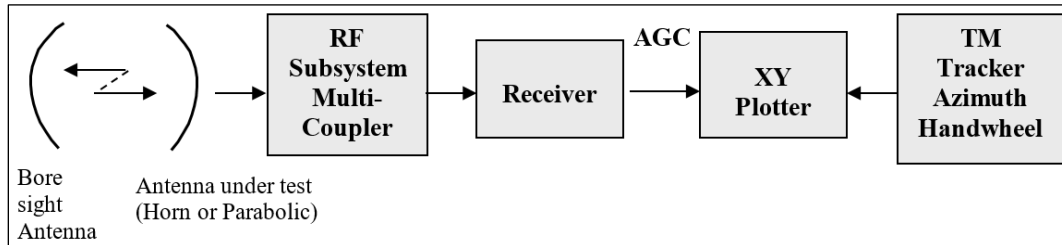

Figure 1-8. Antenna Gain Measurement Using XY Plotter

1. This test assumes that the bore sight antenna is transmitting linear vertical polarization at first and horizontal polarization when the procedure calls for rotating the antenna. Also, the reference horn antenna is assumed to be a linear antenna. If the bore sight antenna transmits circular (left or right), there is no need to rotate the horn antenna. Instead, add the 3-dB difference because of the different polarizations. The same information applies if the reference antenna is circularly polarized and the bore sight antenna is linearly polarized.
2. Calibrate the XY plotter by tuning the bore sight signal generator and test receiver to the bore sight frequency. Most of the time, this bore sight frequency of interest is a common mission frequency or the center of the frequency band. Connect the receiver automatic gain control (AGC) output to the Y-input of the XY plotter. Use the measured noise floor as your reference. Calibrate the XY plotter in 10-dB steps from the measured noise floor to +50 dB using the bore sight signal generator and the test antenna pointing directly to the bore sight antenna. The calibration should be in the center of the XY plotter paper. The remaining calibration should be in 1-dB steps from the known horn antenna gain value to slightly more than the calculated gain in [Subsection 1.8.2](#).
3. If the bore sight antenna is linearly polarized, set up the standard gain horn antenna to the same polarization (vertical with vertical and horizontal with horizontal).

1.8.4.1.3. **Procedure**

1. Point the test antenna (and horn antenna) directly at the bore sight antenna. If the bore sight source is a signal generator, increase the signal RF level output until the tracking receiver indicates at least +20 dB above the receiver noise floor.
2. Ascertain peak signal level by checking for maximum signal in Az/El.
3. Mark the horn antenna maximum gain value on the calibrated XY plotter paper on the right side.

4. Remove the horn antenna and repeat the measurement using the test antenna. Mark the gain of the test antenna (vertical gain) on the right side higher than the horn antenna marking.
5. Rotate the horn antenna 90° to obtain the other linear polarization (horizontal) to repeat the above measurements.
6. Rotate the bore sight antenna 90° similar to the horn antenna for compatible polarizations and repeat steps 4 and 6 (mark on left side of paper).

#### 1.8.4.2 Test Method 2: Strip Chart Recorder

##### 1.8.4.2.1. Conditions. Same as Subsection 1.8.4.1.1

1.8.4.2.2. Setup. Connect the receiver AGC output to the strip chart recorder for vertical deflection (see Figure 1-9). Calibrate the strip chart recorder using the signal generator and receiver AGC output in 10-dB steps from the noise floor up to + 50 dB. Calibrate the recorder in 1-dB steps for values up to ±15 dB from the calculated gain value.

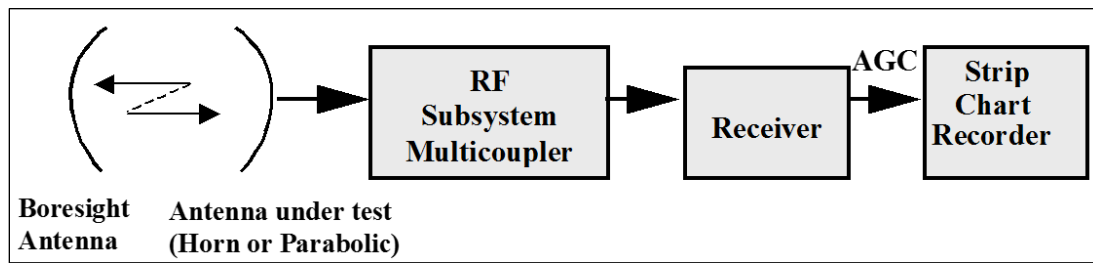

Figure 1-9. Antenna Gain Measurement using a Strip Chart Recorder

1.8.4.2.3. Procedure. Point the test antenna (and horn antenna) directly at the bore sight antenna. Tune the receiver to the bore sight frequency.

1. Ascertain peak signal level.
2. Mark the horn antenna maximum gain value on the strip chart recorder.
3. Remove the horn antenna and repeat steps 1 and 2 for the test antenna.
4. Repeat steps 4 and 6 under Subsection 1.8.4.1.3.
5. Repeat this procedure for the horizontal polarization measurements.

1.8.5 Data Reduction. Add the two values (vertical and horizontal) as shown in the example below. Record the data on Data Sheet 1-8.

Typical gain for a horn antenna @ S-band: +15 dB (reference)

Measured vertical polarization gain above reference: 10 dB

Measured horizontal polarization gain above reference: 11 dB



Vgain = Reference + measured vertical = 25 dB referenced to isotropic  
radiator (dBi)

Hgain = Reference + measured horizontal = 26 dBi

$$10 \cdot \log_{10} N_v = 25 \text{ dB}, N_v = 316.227$$

$$10 \cdot \log_{10} N_h = 26 \text{ dB}, N_h = 398.107$$

Where:

$N_v$  = vertical gain expressed as a power ratio

$N_h$  = horizontal gain expressed as a power ratio.

$$316.227 + 398.107 = 714.334$$

$$10 \cdot \log_{10} (714.334) = 28.539 \text{ dB}$$

$$\underline{\text{Antenna Gain} = 28.5 \text{ dBi}}$$

<b>Data Sheet 1-8. Telemetry Antenna Systems</b>																		
<b>Test 1.8</b>	<b>Antenna gain test</b>																	
<b>Manufacturer:</b>	<b>Model:</b>																	
<b>Serial No.:</b>																		
<b>Test Personnel:</b>	<b>Date:</b>																	
<p style="text-align: center;">Frequency MHz _____</p> <p style="text-align: center;">Standard antenna gain (Gs) dBi _____</p> <p style="text-align: center;"><b>Bore sight antenna polarization</b></p>																		
<table border="1" style="width: 100%; border-collapse: collapse;"> <thead> <tr> <th rowspan="2" style="width: 60%;"></th> <th colspan="2" style="text-align: center;">Gain</th> </tr> <tr> <th style="text-align: center;">(dBi)</th> <th style="text-align: center;">Power ratio</th> </tr> </thead> <tbody> <tr> <td>Tracking antenna vertical polarization gain (G<sub>V</sub>)</td> <td></td> <td></td> </tr> <tr> <td>Tracking antenna horizontal polarization gain(G<sub>H</sub>)</td> <td></td> <td></td> </tr> <tr> <td>Antenna gain N<sub>A</sub> = N<sub>H</sub> + N<sub>V</sub> (power ratio)</td> <td></td> <td></td> </tr> <tr> <td>Antenna gain (dBi) = 10 • log<sub>10</sub> (N<sub>A</sub>)</td> <td></td> <td></td> </tr> </tbody> </table>			Gain		(dBi)	Power ratio	Tracking antenna vertical polarization gain (G <sub>V</sub> )			Tracking antenna horizontal polarization gain(G <sub>H</sub> )			Antenna gain N <sub>A</sub> = N <sub>H</sub> + N <sub>V</sub> (power ratio)			Antenna gain (dBi) = 10 • log <sub>10</sub> (N <sub>A</sub> )		
	Gain																	
	(dBi)	Power ratio																
Tracking antenna vertical polarization gain (G <sub>V</sub> )																		
Tracking antenna horizontal polarization gain(G <sub>H</sub> )																		
Antenna gain N <sub>A</sub> = N <sub>H</sub> + N <sub>V</sub> (power ratio)																		
Antenna gain (dBi) = 10 • log <sub>10</sub> (N <sub>A</sub> )																		

 <p><b>NOTE</b></p>	<p>The cables from the tracking system antenna to the preamplifier and those from the standard gain antenna to the preamplifier should be the same type and length. If this is not possible, it will be necessary to calibrate the cables and compensate the readings to obtain the true gain.</p>
--	--

## 1.9. TEST: Antenna Pattern Test

1.9.1 **Purpose.** The antenna pattern test checks the relationship between the antenna reflector and the FAU. An antenna pattern measurement verifies that the FAU is at the focal point, side-lobe symmetry, and correct level below the main lobe. It is not designed to measure the absolute parameters of the receiving antenna. To measure exact parameters, the antenna must be removed from the tracking system and mounted on a controlled test range.

1.9.2 **Test Equipment.** Bore sight source with an unobstructed view and an XY plotter with good resolution. An antenna recorder could be used in place of the XY plotter.

1.9.3 **Setup.** Connect the test equipment as shown in [Figure 1-10](#).

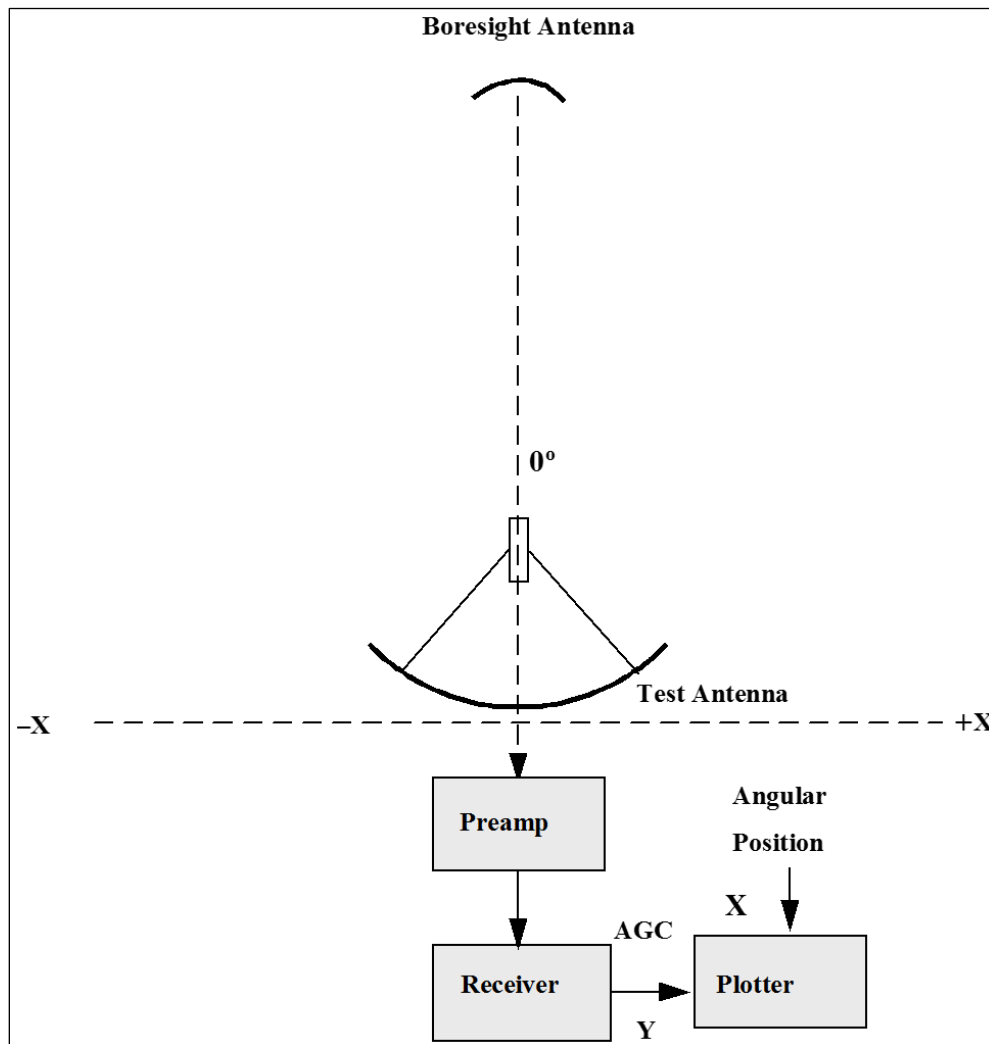



Figure 1-10. Antenna Pattern Measurement Setup

1. Set the bore sight signal level so that the received signal at the tracking receiver is at least 40 dB above the noise level.
2. Adjust the recorder gain so that the bore sight on-axis signal gives maximum recorder displacement.

1.9.4 Conditions. This test should be performed with little or no wind. Multipath can lead to false conclusions. Ascertain that no multipath conditions exist by conducting the test away from any potential reflective surface and at an elevation high enough to prevent ground reflections.

 <b>NOTE</b>	The calibrations used for Subsection <a href="#">1.8</a> should be used including doing a noise floor measurement and calibration for 0 to + 50 dB in 10 dB steps to properly measure the side lobes.
---	---

#### 1.9.5 Procedure

1. Rotate the antenna pedestal to point to the bore sight source. Record the Az/El auto track angles. Set elevation to OFF. Rotate the azimuth axis  $-X$  degrees counterclockwise from the recorded auto track angles. The limits  $-X$  to  $+X$ , for rotating the antenna is normally from  $-180^\circ$  to  $+180^\circ$ . This limit allows an examination of the back lobes as well as the main and side lobes. If the intent of the measurement is to verify the first side-lobe levels and the main lobe for symmetry, then the measurement limits should be decreased to emphasize this desired area. Start the recorder at 5 mm/s (0.2 in/s).
2. The pedestal must be rotated at a constant rate clockwise through the auto track peak angles from  $-X$  to  $+X$  degrees. If the antenna drive system has a rate mode, set it for a movement of  $5^\circ$  per second. If it has only a synchro control mode, the operator must try to keep the rotation rate as near to  $5^\circ$  per second as possible. Although other techniques may be devised, they will not be discussed here.
3. After the pedestal has completed its expected rotation clockwise, stop the recorder and pedestal.
4. Repeat steps 1 through 3 for as many frequencies as desired. Intervals of 25 megahertz (MHz) are usually sufficient.

#### 1.9.6 Data Reduction

1. The antenna response recorded on the strip chart recorder will indicate the side-lobe levels and any major back lobes present. Unsymmetrical side-lobe levels could be caused by a skewed feed. The absence of the first side lobes or lower side-lobe levels could be caused by a feed assembly not at the focal point.
2. To produce a response record for the elevation axes in both directions (down as well as up), the feed assembly must be rotated  $90^\circ$ , and the test conducted as an azimuth movement.

### 1.10. TEST: Feed Assembly Unit

1.10.1 Purpose. This test determines the proper error signal deflections in Az/El generated by the tracking FAU. The errors generated by this unit form the basis for the automatic tracking of a TM tracking system. One test is for a single-channel monopulse (SCM) tracking technique and the other one is for a conical scan tracking technique.

1.10.2 SCM. The SCM tracking technique uses the difference channel signals to amplitude modulate the carrier. The difference channel signals represent the Az/El error offset from bore sight center in the form of square pulses. The amplitude modulation (AM) of the difference

signals is caused by fast switching diodes synchronized by signals from a scan signal generator. The AM output of the tracking receiver separates the error signals from the receiver intermediate frequency (IF) and becomes the input to the TED. Demodulation by the TED separates the Az/EI error signals synchronized by the same scan signals from the scan signal generator. The error pulses are four square wave pulses as shown in [Figure 1-11](#) and [Figure 1-12](#). [Figure 1-11](#) indicates minimum error in Az/EI while [Figure 1-12](#) indicates an azimuth error and an elevation error.

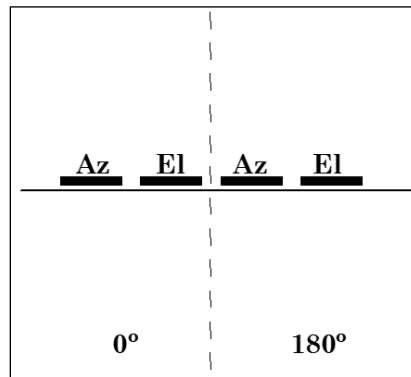

Figure 1-11. SCM Error Pulses Indicating Minimum Error

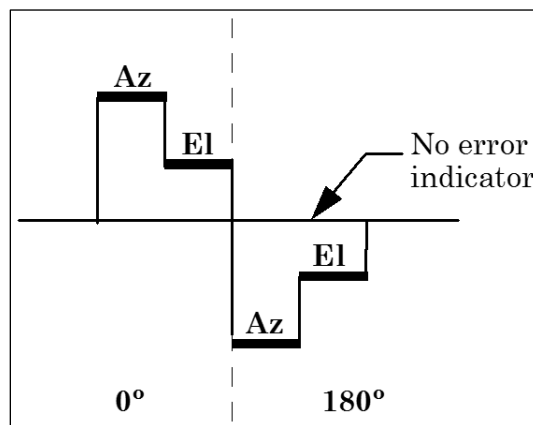

Figure 1-12. SCM Error Signals Indicating Azimuth and Elevation Errors for One Type of SCM Feed

1.10.2.1 **Test Equipment.** Analog or digital oscilloscope. Bore sight transmitting source and radiating antenna.

1.10.2.2 **Setup.** Ensure direct line of sight (LOS) between the TM tracking antenna and the bore sight antenna. Align the demodulator circuits and servo circuits for minimum movement.

1.10.2.3 **Procedure.** Turn the TM tracking system on and allow a minimum of 15-minute warm-up time.

1. Balance the servo system for minimum drift.
2. Tune the receiver to the bore sight source frequency.
3. Point the test feed (antenna) directly to the bore sight source ensuring that no influence from multipath exists.

4. Ensure the bore sight source signal radiates a strong signal of at least +20 dB above the noise floor.
5. Monitor the receiver left circular polarization and right circular polarization AM output or the error input to the TED with the oscilloscope.
6. Use the antenna control handwheel to rotate the antenna to null the error pulses. The Az/EI indicators should display the angles from the test antenna to the bore sight source. When the four pulses form a horizontal straight line (or close to), the error is minimum and the signal level is maximum (see [Figure 1-11](#)). Note that the timing sequences may not be representative of all types of SCM feeds.

**Note:** The timing sequences may not be representative of all types of SCM feeds.

7. Rotate the azimuth handwheel clockwise and the elevation handwheel up no more than 1/2 the 3-dB beam width. The Az/EI error pulses will increase in one direction (for the 0° phase and “mirror image” for the 180° phase). By rotating the antenna in a counterclockwise (and down) direction the Az/EI errors will change directions (see [Figure 1-12](#)).

1.10.2.4 Data Reduction. The error pulses should indicate a definite separation between Az/EI errors at the 0° phase and again at the 180° phase. There should also be a definite separation between the Az/EI error pairs at 0° and Az/EI error pairs at 180°. (See [Figure 1-12](#) for an illustration of correct pulse movement).

1.10.3 Conical Scan Technique. Most conical scan techniques use a 30-hertz (Hz) (or variable from 5 to 35 Hz) scan motor to rotate an eccentric circular waveguide (horn). A vertical and horizontal dipole antenna is normally housed behind the waveguide. The rotation of the horn generates a sine wave that is amplitude modulated by the amount of offset the antennas are from the bore sight center. The amplitude and phase represent the error from the bore sight center that the servo response must correct to maintain auto track. The scan motor is directly connected to an optical commutator. One-half of the rotating cam is clear while the other half is anodized. Two photoelectric lights constantly illuminate the cam generating two square waves that are in-phase quadrature at the scan motor frequency. The proper in-phase relationship between the square pulse and the error sine wave indicates correct alignment of the FAU. The correct phasing of the reference signal pair is optimized to reduce crosstalk between orthogonal tracking channels (see [Figure 1-13](#)).

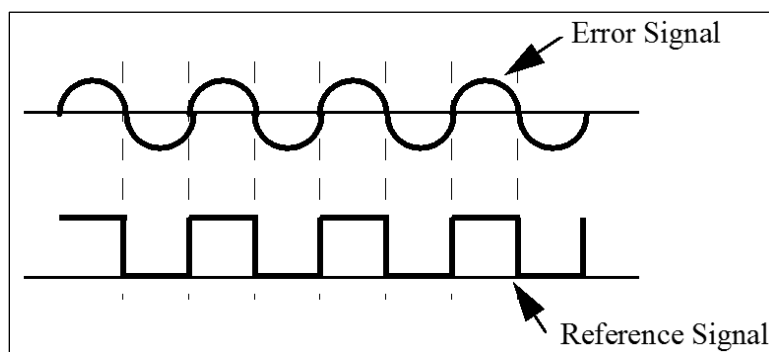

Figure 1-13. Conical Scan Technique Error and Reference Signals Alignment

1.10.3.1 Test Equipment. Dual-trace digital oscilloscope and radiating bore sight antenna.

1.10.3.2 Setup. Ensure direct line-of-sight between the TM tracking system and the bore sight antenna with no multipath interference.

1.10.3.3 Procedure. The radiating source should output a strong signal so the receiving system reads at least +20 dB above the measured noise floor.

1. Point the test antenna at the bore sight antenna and monitor the AM input to the TED and the square wave reference at the TED. Minimum error will be indicated by a very small sine wave.
2. Rotate the pedestal in azimuth only and observe the AM increase. Where the sine wave crosses the zero reference line, observe the square pulse (see [Figure 1-13](#)). The positive going portion of the square pulse should align with the sine wave here. If it is not aligned, determine the amount of channel crosstalk present and the possible reason for the erratic automatic track. The amount of acceptable crosstalk should be known to determine if the FAU needs adjustment.

## 1.11. TEST: Solar Calibration using Linear Receiver Method

1.11.1 Purpose. This test determines the figure of merit (gain/temperature [ $G/T$ ]) of the receiving antenna system. The  $G/T$  is the ratio of the antenna gain to the system noise temperature.  $G$  is the receiving antenna gain minus the losses between the receiving antenna and a reference point.  $T$  is the receiving system temperature comprised of the sum of the antenna noise temperature ( $T_a$ ) and the receiver noise temperature ( $T_r$ ). Therefore, the  $G/T$  is a good measure of the sensitivity of the receiving system. The  $G/T$  is frequently used in link analysis calculations.

1.11.2 Test Equipment. TM receiver with linear IF output and manual gain control (MGC) or AGC hold feature and power meter with square-law detector or true root mean square (rms) voltmeter.

1.11.3 Setup. Connect the test equipment as shown in [Figure 1-14](#).

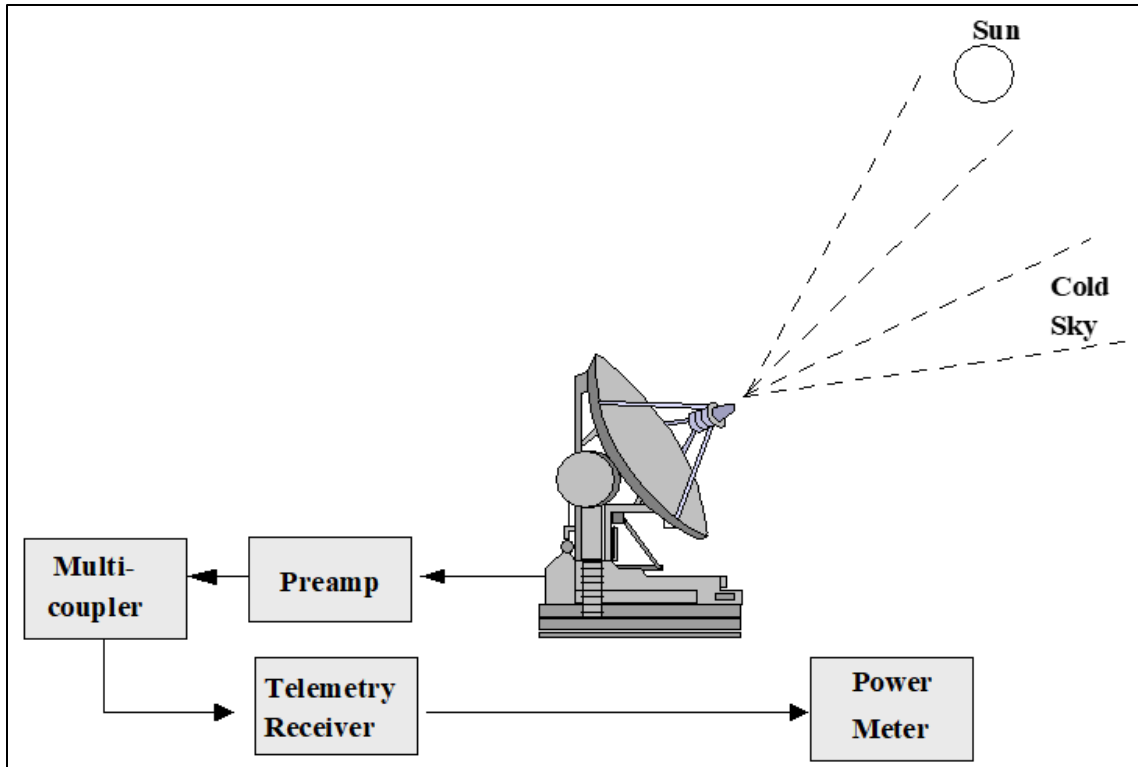

Figure 1-14. Antenna Solar Calibration Using Linear Receiver

1.11.4 Conditions. System must be at operational stability (adequate warm-up period and minimum noise in the servo system) before test is conducted. To make power measurements, the tracker should point at the sun at an elevation angle of at least  $10^\circ$ . An elevation angle of  $10^\circ$  will contribute approximately 10 K to the antenna temperature at frequencies from 1.4 to 2.3 GHz. At higher elevation angles up to  $90^\circ$ , the antenna temperature decreases to 1.8 K.<sup>4</sup> The above figures are based on clear sky and  $7.5 \text{ g/m}^3$  water-vapor concentration. Equation 1-6 can be used to calculate the effects on the system temperature at different elevation angles. See [Appendix C](#) to determine receiving system linearity. Set the receiver center frequency to the desired test frequency. Be aware that interfering signals may invalidate test results.



Care should be taken to prevent solar heat damage to equipment at the focus of parabolic reflectors.

#### 1.11.5 Procedure

1. Point the antenna at the sun. Fix manual gain (engage AGC hold) in the linear portion of the receiver. Record the power meter reading as  $P_2$  ( $V_2$ ).
2. Point the antenna at the cold sky (at least several beam widths away from the sun). The antenna should be rotated in azimuth or elevation to prevent interference from the sun. Record the power meter reading as  $P_1$  ( $V_1$ ).
3. Repeat procedure for other desired frequencies.

<sup>4</sup> Kraus, J. D. *Radio Astronomy*. New York: McGraw-Hill, 1966.



### 1.11.6 Data Reduction

1. Record power meter readings (in dB referenced to one milliwatt [dBm]) on Data Sheet 1-9.
2. Calculate the figure of merit using Equation 1-6 if a power meter was used, or Equation 1-7 if a true rms voltmeter was used. See [Appendix C](#) for additional details about figure of merit calculations.
3. To convert the power flux density measurements into flux densities at the test frequencies, see [Appendix C](#).
4. The units of the measured power flux densities are  $10^{-22}$  W/m<sup>2</sup>/Hz; that is, a reported value of 111 would mean  $111 \cdot 10^{-22}$  W/m<sup>2</sup>/Hz.

$$k_2 = A_g / \sin \alpha \quad (\text{Eq. 1-6})$$

$$\frac{G}{T} = 10 \bullet \log_{10} \left[ \frac{8 \pi k k_2 L}{S \lambda^2} \left[ \frac{P_2}{P_1} - 1 \right] \right] \quad (\text{Eq. 1-7})$$

Where:

- $\lambda$  = test frequency wavelength (in meters)
- $G/T$  = figure of merit in dB/K
- $L$  = correction factor (see [Appendix C](#))
- $k$  = Boltzmann's constant ( $1.380622 \cdot 10^{-23}$  W/Hz/K)
- $k_2$  = atmospheric attenuation (see [Appendix C](#))
- $S$  = solar power flux density (random polarization) in W/m<sup>2</sup>/Hz at the test time and at the test frequency
- $P_1$  = cold sky power meter reading as a power ratio
- $P_2$  = power meter reading looking at the sun as a power ratio

$$\frac{G}{T} = 10 \bullet \log_{10} \left[ \frac{8 \pi k k_2 L}{S \lambda^2} \left[ \frac{V_2^2}{V_1^2} - 1 \right] \right] \quad (\text{Eq. 1-8})$$

Where:

- $V_1$  = true voltmeter reading antenna pointing at the cold sky
- $V_2$  = true voltmeter reading antenna pointing at the sun

Solar power flux density (S) at the test frequency will need to be interpolated from data measured by the National Oceanic and Atmospheric Administration (NOAA) at specific frequencies. These procedures are included in [Appendix C](#).



**NOTE**

Solar flux measurements are made daily by radio observatories at 245, 410, 610, 1415, 2695, 4995, 8800, and 15400 MHz. Measurements from Sagamore Hill Radio Observatory are the optimal values for the continental United States. For sites outside of the continental United States use values from the nearest radio observatory.

Contact Information:

DSN 272-8087 or commercial (402) 232-8087

Internet:

<ftp://ftp.swpc.noaa.gov/pub/lists/radio/rad.txt>

or

<http://services.swpc.noaa.gov/text/current-space-weather-indices.txt>

<b>Data Sheet 1-9. Telemetry Antenna Systems</b>					
<b>Test 1.9</b>		<b>Solar calibration using linear receiver method</b>			
<b>Manufacturer:</b>			<b>Model:</b>		<b>Serial No.:</b>
<b>Test Personnel:</b>					<b>Date:</b>
Time:			Location:		
Meter type: power meter:			True RMS voltmeter:		
Antenna beam width:			Aperture correction factor (L):		
Receiver No.:			Receiver IF bandwidth:		
<b>Measured Solar Flux Data</b>					
<b>Frequency</b>	610	1415	2695	4995	8800
<b>Solar Flux</b>					
<b>Frequency</b>	<b>Corrected solar flux</b>	<b>Polarization</b>	<b><math>P_2</math> (V<sub>2</sub>) (sun)</b>	<b><math>P_1</math> (V<sub>1</sub>) (cold sky)</b>	<b>Figure of merit</b>

## 1.12. TEST: Solar Calibration using Attenuator Method

1.12.1 Purpose. This test determines the figure of merit ( $G/T$ ) of the receiving antenna system. The  $G/T$  is the ratio of the antenna gain to the system noise temperature.  $G$  is the receiving antenna gain minus the losses between the receiving antenna and a reference point.  $T$  is the receiving system temperature comprised of the sum of the antenna noise temperature ( $T_a$ ) and the receiver noise temperature ( $T_r$ ). Therefore, the  $G/T$  is a good measure of the sensitivity of the receiving system. The  $G/T$  is frequently used in link analysis calculations.

1.12.2 Test Equipment. TM receiver with linear IF output and MGC or AGC-hold feature, power meter with square-law detector or true rms voltmeter, and precision attenuator.

1.12.3 Setup. Connect the test equipment as shown in [Figure 1-15](#).

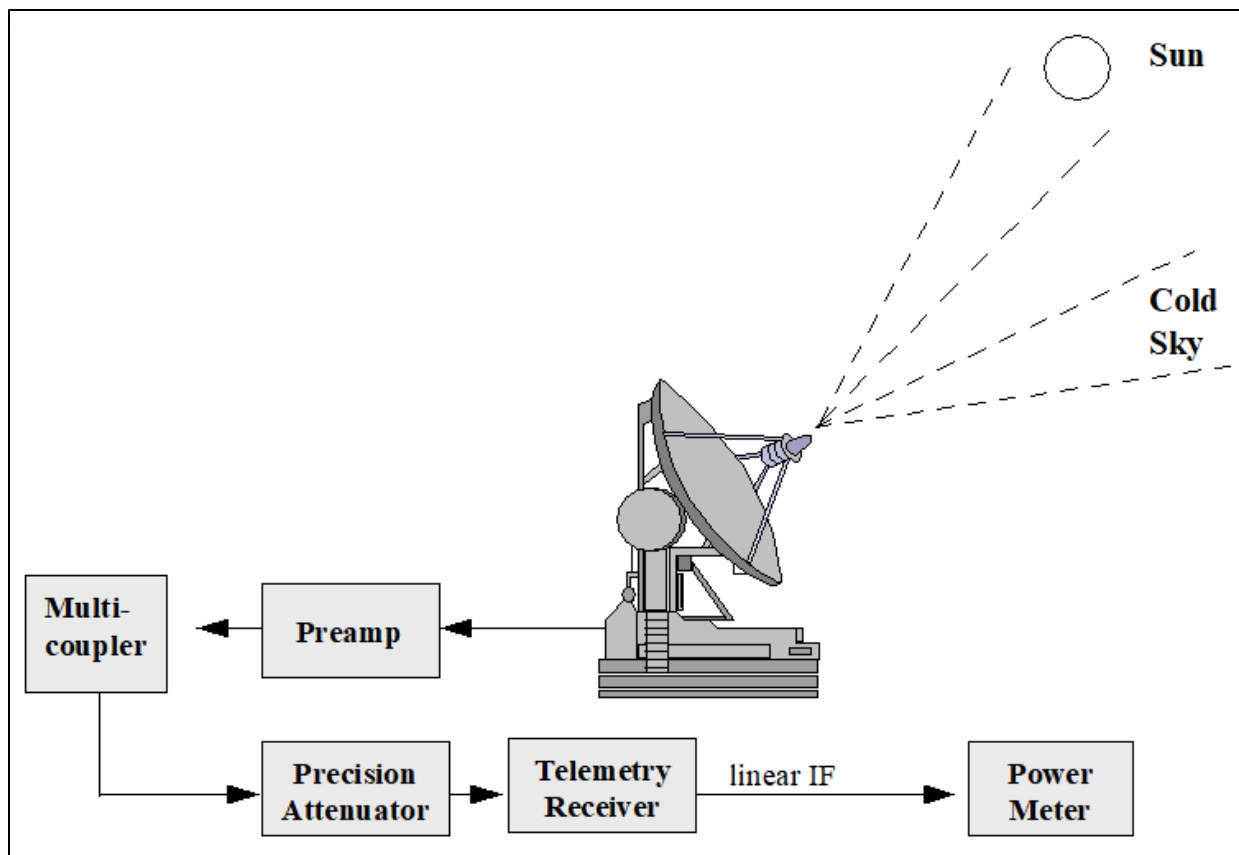

Figure 1-15. Antenna Solar Calibration using Attenuator

1.12.4 Conditions. The system must be at operational stability before the test is conducted. To make power measurements, the tracker should point at the sun at an elevation angle of at least  $10^\circ$ . An elevation angle of  $10^\circ$  will contribute approximately 10 K to the antenna temperature at frequencies from 1.4 to 2.3 GHz. At higher elevation angles up to  $90^\circ$ , the antenna temperature decreases to 1.8 K (Kraus, 1966). The above figures are based on clear sky and  $7.5 \text{ g/m}^3$  water-vapor concentration. To determine receiving system linearity, see [Appendix C](#). Set the receiver center frequency to the desired test frequency. Be aware that interfering signals may invalidate test results.

### 1.12.5 Procedure

1. Point the antenna at the cold sky (at least several antenna beam widths away from the Sun). Set the attenuator to zero. Set manual gain in the linear portion of the receiver range. Record power meter (true rms voltmeter) reading on Data Sheet 1-10 as  $P_x (V_x)$ .



Care should be taken to prevent solar heat damage to equipment at the focus of parabolic reflectors.

2. Point the antenna at the sun. Increase attenuation so the power meter (true rms voltmeter) again reads  $P_x(V_x)$ . Record the attenuator reading on Data Sheet 1-10.
3. Repeat the procedure for other frequencies as desired.

### 1.12.6 Data Reduction

1. Convert the amount of attenuation necessary to obtain a meter reading equal to  $P_x (V_x)$  to a power ratio and use in Equation 1-8 for calculating  $G/T$  in place of  $P_2/P_1$ , that is,

$$\frac{G}{T} = 10 \log_{10} \left[ \frac{8\pi k k_2 L (10^z - 1)}{S \lambda^2} \right] \quad (\text{Eq. 1-9})$$

Where:

$Y$  = attenuator reading (in dB)

$z$  =  $Y/10$

$\lambda$  = test frequency wavelength (meters)

$L$  = aperture correction factor (see [Appendix C](#))

$k$  = Boltzmann's constant ( $1.380622 \cdot 10^{-23}$  W/Hz/K)

$k_2$  = atmospheric attenuation (see [Appendix C](#))

$S$  = solar power flux density (random polarization) in W/m<sup>2</sup>/Hz

2. Solar power flux density ( $S$ ) at the test frequency will need to be interpolated from data measured by NOAA at specific frequencies. These procedures are included in [Appendix C](#).

#### NOTE



Solar flux measurements are made daily by radio observatories at 245, 410, 610, 1415, 2695, 4995, 8800, and 15400 MHz. Measurements from Sagamore Hill Radio Observatory are the optimal values for the continental United States. For sites outside of the continental United States use values from the nearest radio observatory.

Contact Information:

DSN 272-8087 or commercial (402) 232-8087

Internet:

<ftp://ftp.swpc.noaa.gov/pub/lists/radio/rad.txt>

or

<http://services.swpc.noaa.gov/text/current-space-weather-indices.txt>

Data Sheet 1-10. Telemetry Antenna Systems					
Test 1.10		Solar calibration using attenuator method			
Manufacturer:			Model:		Serial No.:
Test Personnel:				Date:	
Time: _____			Location: _____		
Solar flux at 1415 MHz:		Solar flux at 2695 MHz:			
Meter type: power meter:		True RMS voltmeter:			
Antenna Beam Width		Aperture correction factor (L):			
Receiver No.:		Receiver IF bandwidth			
<b>Measured Solar Flux Data</b>					
<b>Frequency</b>	610	1415	2695	4995	8800
<b>Solar Flux</b>					
<b>Frequency</b>	<b>Corrected solar flux</b>	<b>Polarization</b>	<b>Attenuator dB (sun)</b>	<b><math>P_1</math> (V<sub>1</sub>) (cold sky)</b>	<b>Figure of merit</b>

### 1.13. TEST: Pedestal Motion Testing

1.13.1 Purpose. This task is to provide a common method for determining and assessing the dynamic motion and tracking accuracy of a telemetry pedestal. The test will use hardware in the loop (HWIL) equipment to simulate a target and generate the necessary antenna control unit (ACU) and amplitude modulated error input signals to drive the antenna as it would normally be driven when tracking a real target. See [Figure 1-16](#).

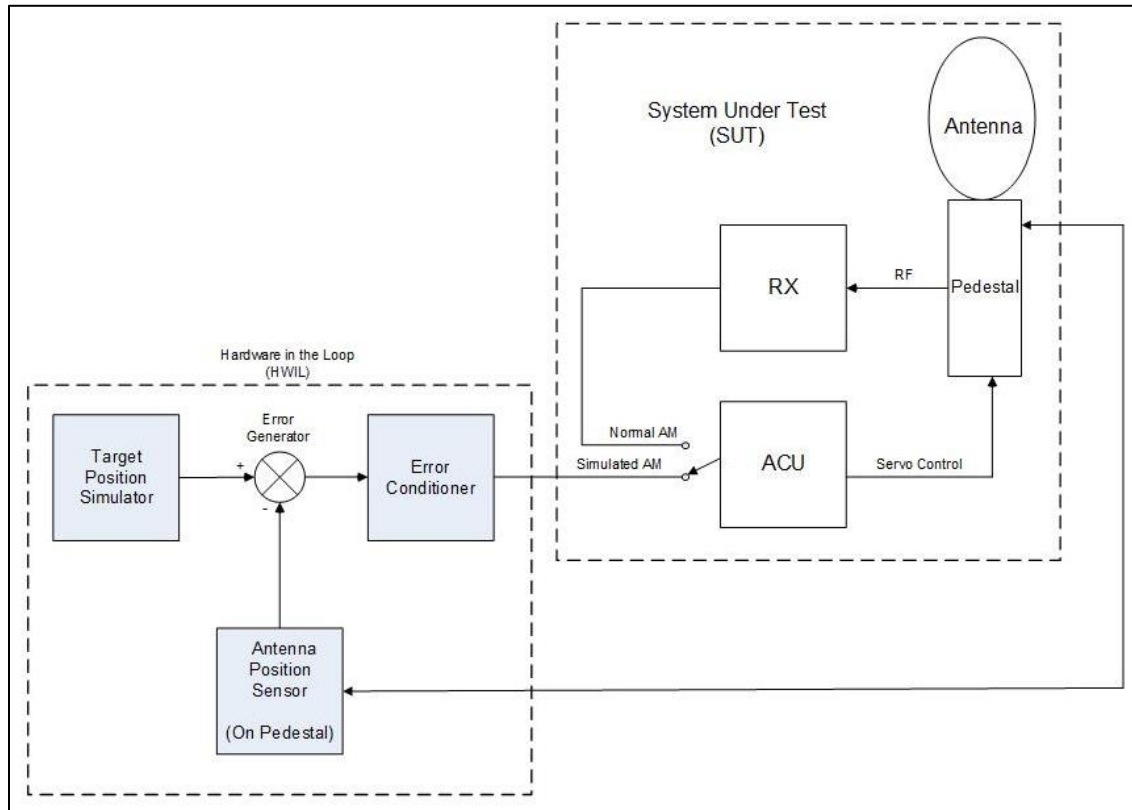

Figure 1-16. Hardware in the Loop Configuration

The general test methodology discussed in this procedure can characterize the tracking performance of a conical scan or SCM tracking antenna, but the concepts described in this procedure can be adopted for any tracking antenna technology. The HWIL equipment takes the error between a simulated target position and the true antenna pointing angle and generates the appropriate error signal for input to the ACU. The ACU interprets this input as if it were tracking a normal target and moves the antenna towards the target. It is critical that the simulation outputs and interfaces to the antenna be of sufficient quality as to not impact the SUT response.

The following HWIL component functions are described, along with one potential implementation method. An infinite number of implementation methods can be developed, each with its own set of strengths and weaknesses.

1.13.1.1 Target Position Simulator. The target position simulator supplies the simulated target position with respect to time. This component houses the flight path generation equipment and is not impacted by antenna position.

1.13.1.2 Error Generator. This component takes in the antenna position and the target position and creates a value for the pointing error of the antenna. If the antenna error is greater than the tracking beamwidth of the antenna, usually the 3-dB point, then it can be assumed that the antenna can no longer accurately track the target. Since stressful antenna tracking scenarios usually occur when targets are relatively close to the antenna, and the incoming signal strength is high, the Null to Null tracking point could be used as the reference. See [Figure 1-17](#).

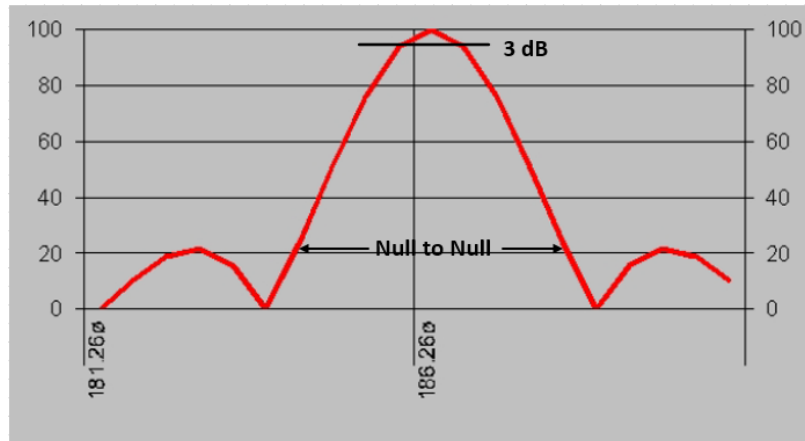

Figure 1-17. Antenna Pattern

1.13.1.3 Error Conditioner. This component converts the output of the error generator into a format that can be natively understood by the SUT. It is important that the fidelity of the error signal coming from the error conditioner be as close as possible to the native error signal coming from the antenna when it tracks a real target so that the difference is unperceivable to the SUT (in fidelity, accuracy, and timeliness). If this is not the case, then the HWIL may significantly influence the SUT performance.

1.13.1.4 Antenna Position Sensor. This component, mounted on the pedestal, senses the position of the antenna and forwards that to the error generator. It is important to note that the antenna position sensor be of sufficient accuracy that it can segment the antenna beamwidth into small enough segments as to not impact the SUT. Usually  $1/10^{\text{th}}$  of a 3-dB beamwidth is sufficient for this purpose. It is also important that the antenna position sensor be referenced to the correct coordinate system. In other words, if the antenna position sensor is referenced to the antenna pedestal then pointing error sources that are external to the antenna system (such as mounting flex, antenna misalignment, or tower sway) will not be captured as contributors to the tracking system error. However, if the antenna position sensor is referenced to a global reference frame then all contributors to the tracking system error will be captured. It is also possible to test the antenna mount/tower separately to determine the magnitude of its contribution and integrate an antenna mount model (if desired) into the HWIL components to account for it.

1.13.1.5 Uncaptured Error Sources. It is also important to note that RF-related errors (such as the effect of antenna beam misalignment due to antenna dynamics) is not captured as part of the described system. Effects such as dish flex, spar flex, and feed displacement due to antenna movement can have a significant impact on antenna tracking performance. This section only describes the basic system. Additions to this system can be developed to further expand the system's capability, but those are beyond the scope of this document.



1.13.2 Standard Trajectories and Tests. There are four test trajectories that can describe the primary tracking functions of a telemetry antenna. These tests produce four standard metrics. Other tests may be developed using the target generator to further specify an antenna, but these are presented as a starting point. The four standard tests are described below.

1.13.2.1 Maximum Azimuth Tracking Velocity (MATV) Test. The velocity at which the antenna error (difference between pointing angle and simulated target position) exceeds the tracking beamwidth of the antenna is the MATV of the antenna. Obtaining the MATV is done by simulating a target that is centered at  $0^\circ$  elevation and moving it such that the antenna's angular velocity slowly increases at a rate of  $0.1$  to  $0.5^\circ/\text{sec}^2$ . The test can be repeated in clockwise and counterclockwise rotations. Since this is solely a velocity test, the acceleration values were chosen to be sufficiently low as to decouple the antenna acceleration limitation from the MATV test. The other tests are designed to test acceleration limitations and acceleration with velocity interactions. This test may have to be adjusted to account for azimuth rotational limitations related to cable wrap systems.

1.13.2.2 Maximum Standard Flyby (MSF) Test. Obtaining the MSF is done by simulating a target that will originate significantly far away (15-20 nm) and fly by the antenna with a flight path offset 1 nm from the antenna (1 nm minimum tangential range). The simulated target's velocity is increased in successive runs until the antenna can no longer maintain the target within the tracking beamwidth of the antenna. The maximum target velocity that can be presented to the antenna, while still maintaining it within the tracking beamwidth, is the MSF. This test can also be accomplished at different target altitudes to provide additional insight into antenna performance.

1.13.2.3 Maximum Instantaneous Velocity (MIV) Test. The MIV or "bottle rocket test" is determined by simulating a target that originates 1 nautical mile away from the antenna and moves tangentially with respect to the antenna. The target goes from stationary to a set velocity instantaneously. This is usually performed as an elevation test simulating a bottle rocket-like profile. The velocities are increased in successive simulation runs. The MIV that the antenna can maintain, within the tracking beamwidth of the antenna, is the MIV of the system.

1.13.2.4 Mid-Course Maneuver (MCM). This test is designed to be used with an ACU that is using a predictive analysis tool in its tracking algorithm. The MCM test is a derivative of the MIV test with the addition of a major ( $>30^\circ$ ) target maneuver in Az/El at the midpoint of the flight profile. This tool is often used to reduce standard tracking lag by predicting the future target position and driving the servo in the direction of the predicted target position. This will cause the system to track closer to the target, thus reducing the tracking lag. The MCM test is used to validate the ACU's ability to continue tracking during a sudden change in the flight profile.

1.13.3 System Description. The detailed system configuration as shown in [Figure 1-18](#) is described below.

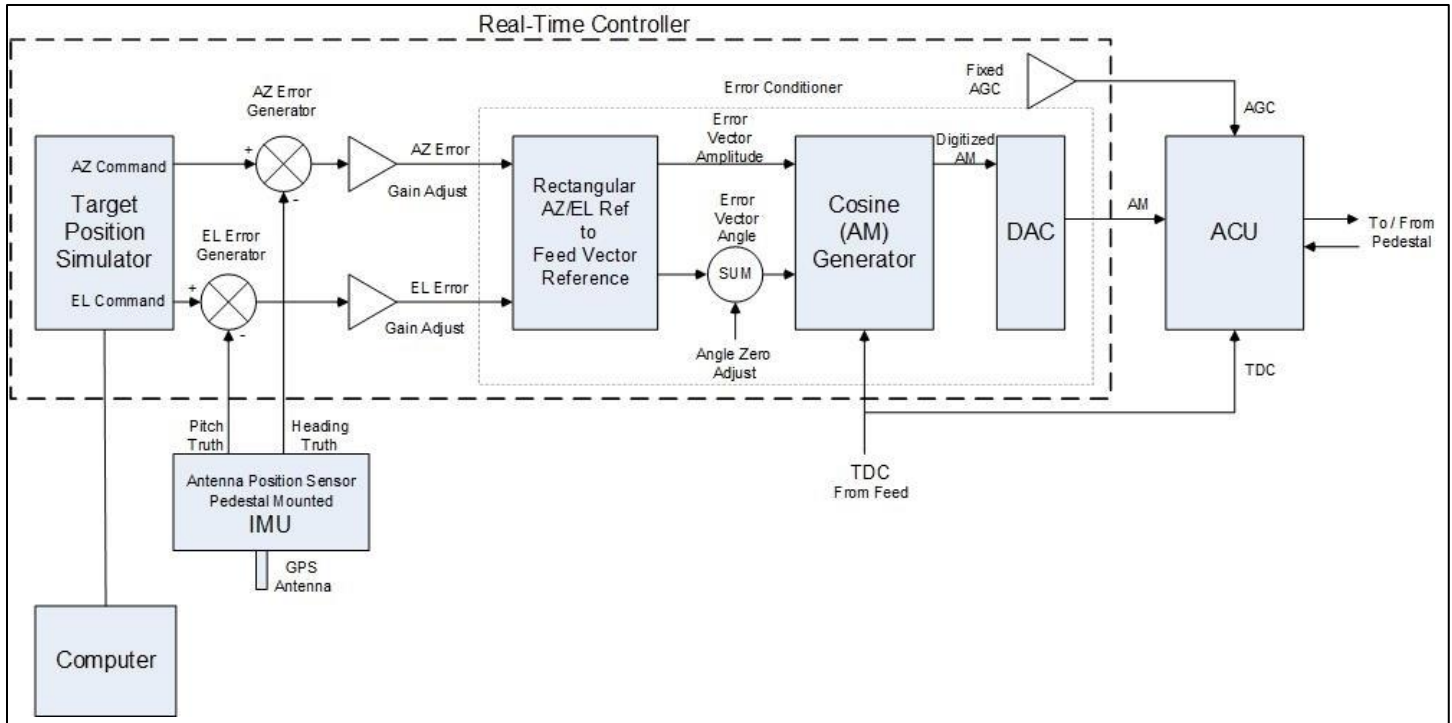

Figure 1-18. Detailed System Configuration

1.13.3.1 Inertial measurement unit (IMU). The IMU mounted on the antenna yoke arm outputs heading, pitch, and roll attitude angles for rates of up to  $\pm 200^\circ/\text{sec}$ . The advantage of an external IMU is its ability to reference the antenna pointing position to a global reference point. This accounts for changes in antenna position based on tower movements and other external inputs to the SUT. An azimuth angle of  $0^\circ$  corresponds to a heading of  $0^\circ$  while an elevation angle of  $0^\circ$  corresponds to a pitch angle of  $0^\circ$ . Azimuth and heading are positive in the same direction, clockwise. Elevation and pitch are positive in the same direction, up from the horizon.

1.13.3.2 The real-time controller (RTC) includes the following.

1.13.3.2.1. Target Position Simulator: The simulated test flight trajectory needs to be decomposed into the local level antenna reference frame in Az/El components. This is the same angular data format used by the IMU and will allow a direct comparison of the two angular data sets.

1.13.3.2.2. Rectangular Converter: The error signal, in Az/El components, is converted to a corresponding AM error signal (with phase) by first using a simple rectangular-to-polar conversion. The elevation value is the “X” component and the azimuth value is the “Y” component. This is due to the zero reference angle defined in the standard conversion as being aligned to the X-direction. In conical scan, the zero reference angle is defined in the positive pitch direction - the Y-direction graphically speaking. Once the amplitude and phase are found, they are used in the simple cosine signal function (Equation 1-10). The process is shown graphically in [Figure 1-19](#).

$$AM \text{ Error Signal} = A \cos(2\pi ft - \theta) \quad (\text{Eq. 1-10})$$

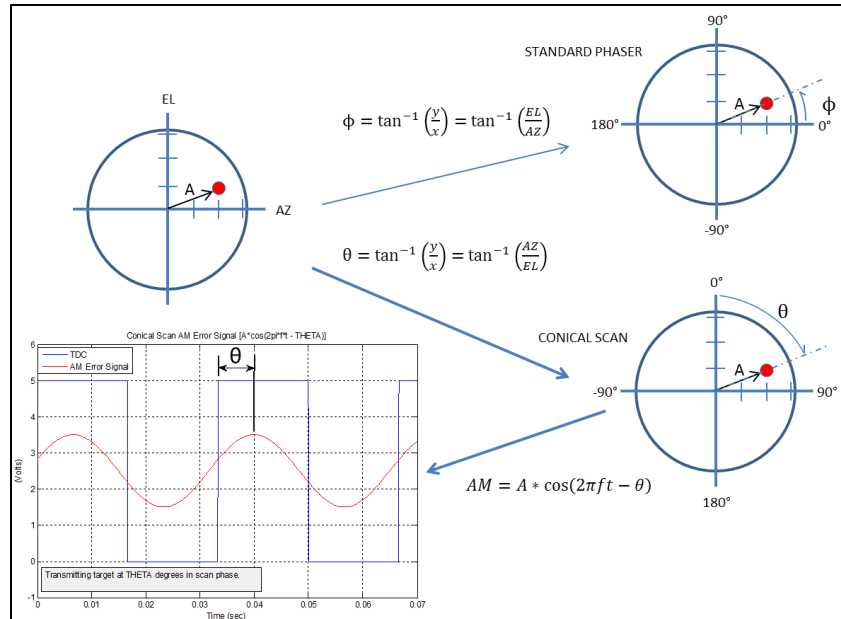

Figure 1-19. Converting AM to TDC Reference

1.13.3.2.3. Cosine Generator: Once the amplitude and phase of the AM error signal are calculated in the feed reference, the  $\theta$  and amplitude parameters are input to a cosine wave generator. The cosine wave frequency is the emulated conical scan frequency or SCM frequency and can vary from 10 Hz to 2000 Hz as a fixed user input parameter or synchronized to the input top dead center (TDC) pulse.

1.13.3.2.4. Computer: The computer is used to monitor the HWIL equipment and collect data. The computer also has four profile generators, one for each type of flight profile.

1.13.4 Setup. Connect the equipment as shown in [Figure 1-18](#).



Special care must be taken to firmly attach the IMU to the pedestal. Any movement between the IMU and the pedestal will skew the results.

### 1.13.5 System Calibration

#### 1.13.5.1 Error Amplitude and Phase Calibration

1. Alignment and calibration verifies that the RTC output amplitude (peak-to-peak) and phase (relative to the TDC pulse) are correctly recognized by the ACU. Independent Az/El gain adjustment, along with a scan angle zero adjustment, is incorporated into the closed loop system as shown in [Figure 1-18](#). The adjustments are used to calibrate and align the HWIL equipment with the SUT.
2. With the servos disabled, use the following steps to adjust the RTC error signal so that a  $1^\circ$  angle offset in Az/El corresponds with a  $1^\circ$  error in the same direction(s) as displayed on the ACU.
3. Manually set antenna pedestal angles to  $0^\circ$  in both Az/El. Turn off the servo.
4. Command the IMU to generate  $0^\circ$  in both Az/El.

5. Set the Target Position Simulator for 0° azimuth and 1° elevation.
6. Observe the ACU crosshair position, which should go to the 12 o'clock position. The error amplitude should be at the 1° crosshair marker. The ACU azimuth error should be zero. Adjust 'Angle Zero Adj' to zero the ACU azimuth error indicator.
7. Adjust 'EL Gain' for an ACU +1° elevation error value. If the 'AZ Error' indicator changes from zero, use 'Scan Angle Adj' to re-zero the 'AZ Error'.
8. Repeat steps 5 through 7 for each setting in [Table 1-2](#).

<b>Table 1-2. Calibration Test Points</b>			
<b><u>AZ</u></b>	<b><u>EL</u></b>	<b><u>ACU Error Magnitude</u></b>	<b><u>ACU Error Angle</u></b>
0°	0°	0°	--
0°	1°	1°	0°
1°	0°	1°	90°
0°	-1°	1°	180°
-1°	0°	1°	270°
1°	1°	-	45°
-1°	-1°	-	225°

#### 1.13.5.2 Antenna Movement Verification

1. Manually set antenna pedestal angles to 0° in both Az/El. Turn off the servo.
2. Command the IMU to generate 0° in Az/El.
3. Set the target position simulator for each of the Az/El settings shown in [Table 1-2](#).
4. For each of the Az/El settings in [Table 1-2](#) turn the servo on. Turn 'Track On' and confirm the antenna moved to the correct setting.

#### 1.13.6 Trajectory Simulation

1. Load the target position simulator with the desired flight trajectory.
2. Set the IMU to output pitch and heading data.
3. Turn on the servo and move the antenna to the trajectory start point.
4. Start the target position simulator.
5. Select 'Track on ACU' to allow the antenna to move in the simulated profile.
6. At the completion of the profile turn off the servo.
7. Plot the commanded vs actual position, velocity, and acceleration data. Refer to [Figure 1-20](#), [Figure 1-21](#), and [Figure 1-22](#).

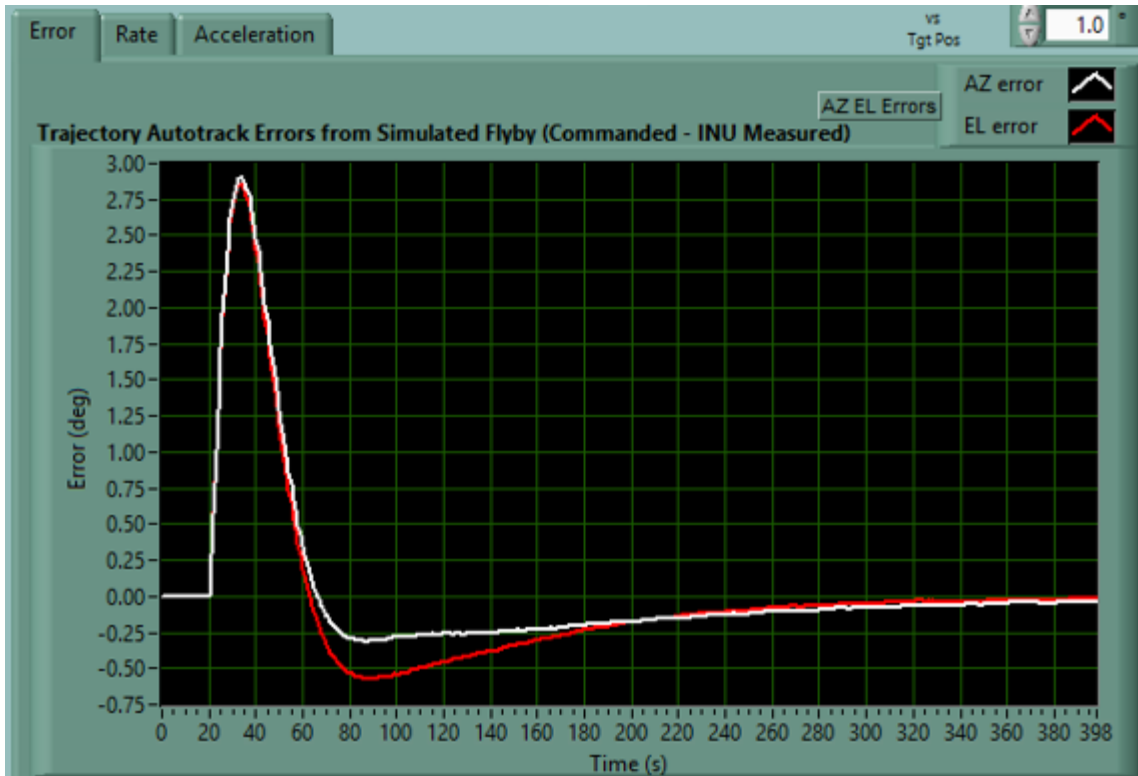

Figure 1-20. Example MIV Position Error

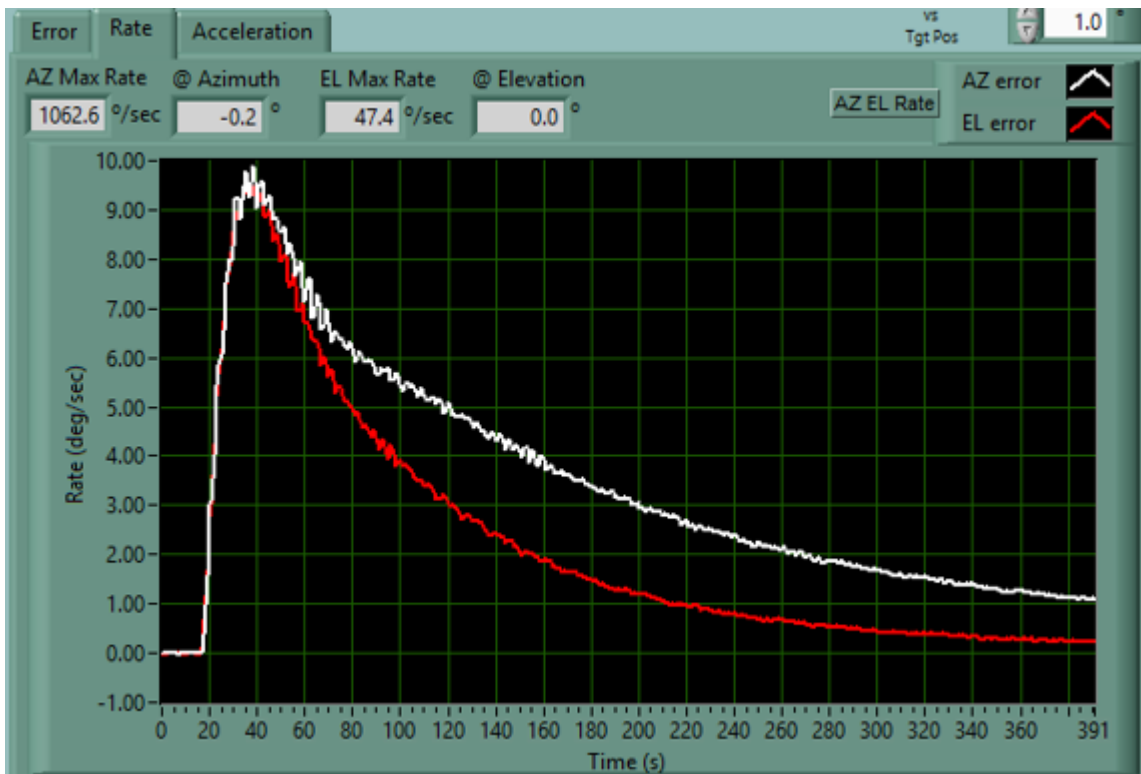

Figure 1-21. Example MIV Antenna Angular Rates

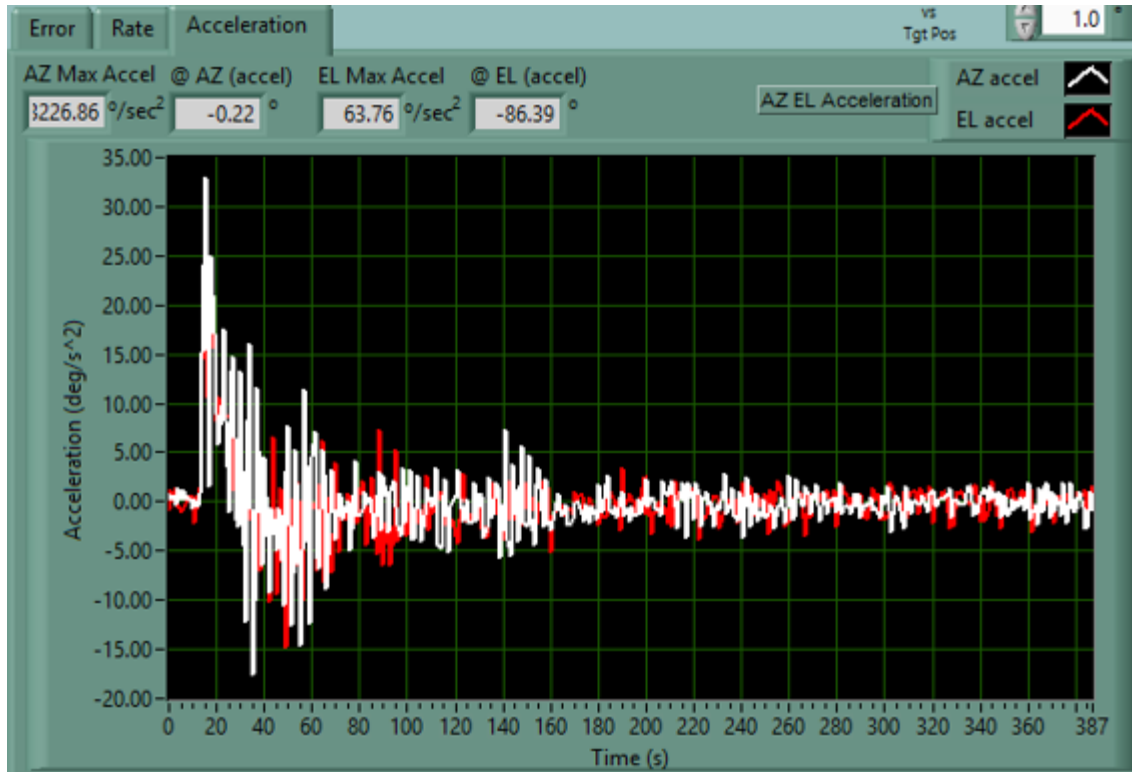

Figure 1-22. Example Maximum MIV Antenna Acceleration

8. Verify the antenna position deltas between commanded and actual position were within the 3-dB points for the antenna beamwidth.

## CHAPTER 2

### Test Procedures for Telemetry RF Preamplifiers

#### 2. General

This chapter describes the test procedures used in measuring the performance parameters of TM RF preamplifiers. Included are methods for determining the range of linear operation by measuring intermodulation (IM) products, gain compression level, power (small-signal) gain, bandwidth, intercept point (IP), voltage standing wave ratio (VSWR), noise figure, and gain variation because of temperature and supply voltage. [Table 2-1](#) lists the types of tests and their test and paragraph number.

<b>Table 2-1. Test Matrix for TM RF Preamplifiers</b>	
<b>Test Number</b>	<b>Test Description</b>
<a href="#">2.1</a>	Amplifier gain compression
<a href="#">2.2</a>	Bandwidth and small-signal power gain
<a href="#">2.3</a>	IM products and IP
<a href="#">2.4</a>	VSWR by return loss
<a href="#">2.5</a>	Noise figure using automatic noise figure meter
<a href="#">2.6</a>	Impedance mismatch

#### 2.1. TEST: Amplifier Gain Compression

2.1.1 **Purpose.** This test measures the 1-dB compression point that is defined as the point where the gain of an amplifier has been decreased 1 dB from the small-signal gain. Gain compression results from nonlinear operations of amplifiers and is a major cause of IM noise that can increase the bit error rate (BER) in digital systems and cause distortion in analog systems.

 <b>NOTE</b>	Perform this test at various frequencies if necessary as 1 dB compression is not constant across the entire band, especially with wide-band amplifiers.
--	---

2.1.2 **Method:** Power Meter as the measuring device.

2.1.3 **Test Equipment.** Signal generator and power meter (2), 3-dB directional coupler.

2.1.4 **Setup.** Connect the test equipment as shown in [Figure 2-1](#).

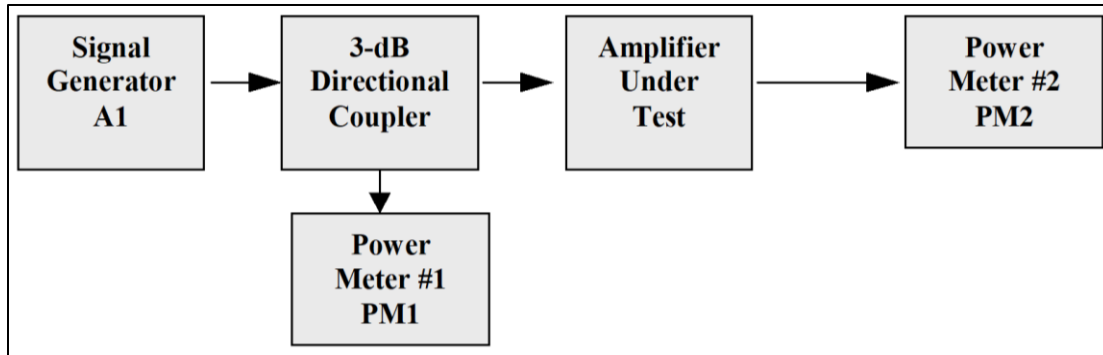

Figure 2-1. Test Setup for Measurement of Amplifier Gain Compression

2.1.5 Conditions. Perform this test under laboratory conditions after a warm-up time of at least 30 minutes. All procedures are conducted with continuous-wave signals (unmodulated) into the device under test.



Do not exceed the amplifier manufacturer's maximum recommended input power because permanent damage to the amplifier may result.

#### 2.1.6 Procedure

1. Connect the amplifier between the signal generator and the power meter as illustrated in [Figure 2-1](#).
2. Apply a low-level signal to the amplifier input and record the power output level from both power meters as  $P_1$  for power meter number one and  $P_2$  for power meter number two on Data Sheet 2-1.
3. Allow the power meters to settle before annotating the power meter readings.
4. Increase the low-level signal by decreasing the attenuator setting,  $A_1$ , on the signal generator.
5. Record the power meter readings on Data Sheet 2-1.
6. Continue this incremental increase until the gain is 1 dB less than the gain in the first step. This condition is known as the 1-dB compression point. Any further increase in the input signal level would drive the amplifier into the nonlinear region of the amplifier and possibly generate IM products.

#### 2.1.7 Data Reduction

1. Calculate and record the gain of the amplifier after each 1-dB increase in input power using equation 2-1.

$$G = P_2 - P_1 \quad (\text{Eq. 2-1})$$

Where:

$G$  = amplifier gain (dB)  
 $P_1$  = power input (dBm)



$P_2$  = power output (dBm)

2. Plot amplifier output power versus input power and note where the output level decreases 1 dB from the linear extrapolation of amplifier response as illustrated in [Figure 2-2](#). This is the amplifier gain compression level. Record the input/output gain compression level on Data Sheet 2-1.

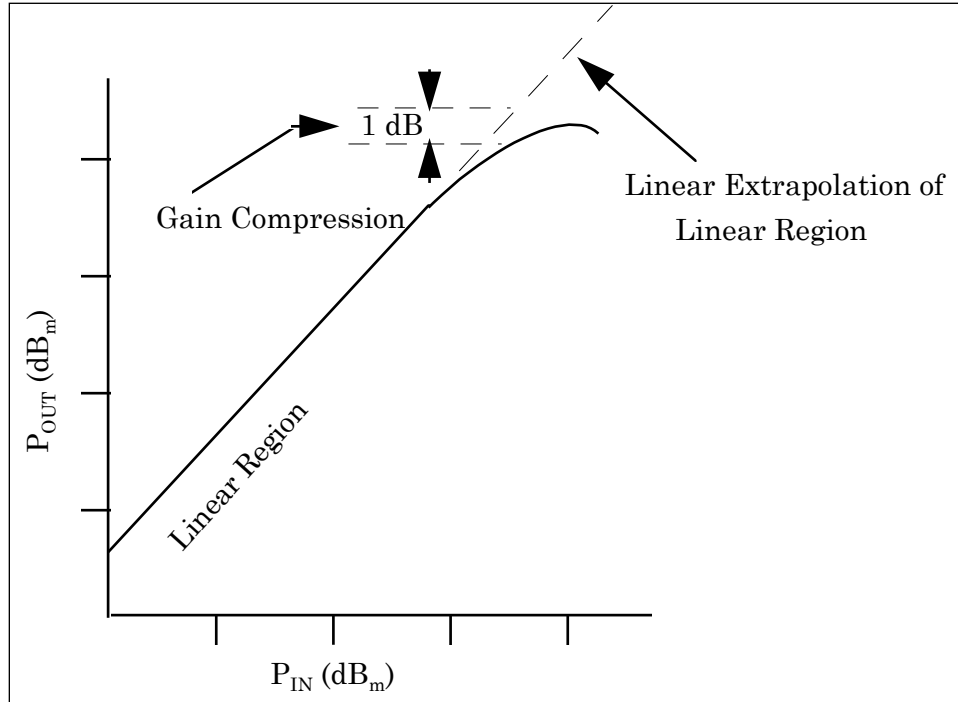

Figure 2-2. Amplifier Gain Compression

<b>Data Sheet 2-1. Test Procedures for Telemetry RF Preamplifiers</b>		
<b>Test 2.1</b>		<b>Amplifier gain compression method: power meter measurement</b>
<b>Manufacturer:</b>		<b>Model:</b>
<b>Test Personnel:</b>		<b>Serial No.:</b>
		<b>Date:</b>
<b>RF Input Power <math>P_1</math> (dBm)</b>	<b>RF Output Power <math>P_2</math> (dBm)</b>	<b>Gain: <math>G = P_2 - P_1</math> (dB)</b>
Test Frequency: _____ 1 dB compression point: $P_0$ _____ (dBm) $P_i$ _____ dBm Take additional readings where data slope changes abruptly.		

## 2.2. TEST: Bandwidth and Small-signal Power Gain

2.2.1 Purpose. This test measures bandwidth, which is defined as the range of frequencies over which the amplitude response does not decrease more than 3 dB relative to the response at the reference point (such as the center frequency) over the specified frequency band of the device under test. The amplifier small-signal power gain is the ratio of output power to input power in the linear operating range and is generally expressed in dB (assuming the impedance of the input/output circuits are properly matched). It is not uncommon to eliminate the specification for 3-dB bandwidth, especially when a band pass filter is utilized prior to the low noise amplifier. The band pass filter will establish the 3-dB bandwidth. Operational frequencies are commonly used to identify band edges and optimized for best flatness across the band. Sometimes it is required to specify out of band gain. Out-of-band gain shall not exceed in band gain.

2.2.2 Test Equipment. Signal generator, spectrum analyzer, sweep oscillator, and attenuator. (Attenuators are needed if the signal generator is not a newer model that includes precision attenuators).

2.2.3 Setup. Connect the test equipment as shown in [Figure 2-3](#). (Either method illustrated is acceptable.)

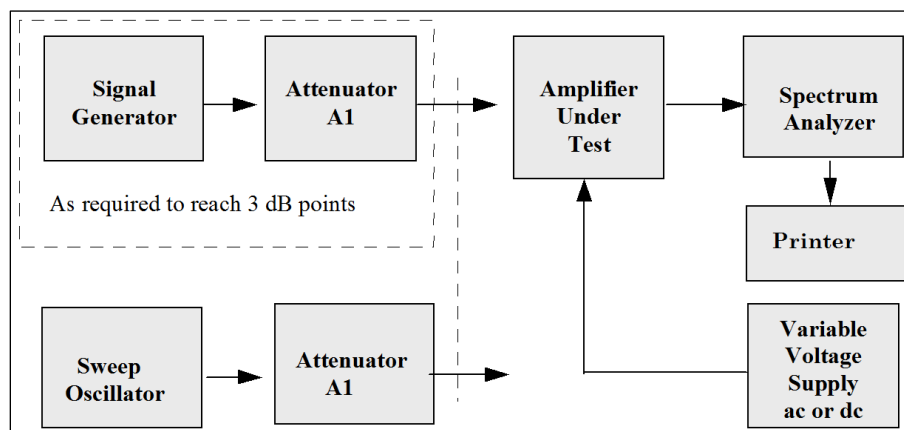



Figure 2-3. Test Setup for Measurement of Bandwidth and Small-signal Power Gain

2.2.4 Conditions. Perform this test under laboratory conditions after a warm-up time of at least 30 minutes. All procedures are conducted with continuous wave signals (unmodulated) into the device under test. Variations in supply voltage will be evaluated.

### 2.2.5 Procedure

1. Set the signal generator frequency to the center of the passband for the device under test.
2. Set the attenuator A<sub>1</sub> to provide a preamplifier output at the spectrum analyzer at least 10 dB below the 1-dB compression level of the amplifier as determined in Test [2.1](#).
3. Adjust the spectrum analyzer to display the frequency signal in the linear operating range at a convenient reference level on the log scale such as 0 dB. The spectrum analyzer vertical display must be operating in the log mode.

4. Disconnect the amplifier and connect the analyzer to the attenuator. Record on Data Sheet 2-2, as the gain of the preamplifier, the difference between the signal now displayed and the reference level in step 3.
5. Reconnect the amplifier ([Figure 2-3](#)) and tune across the band. Note and record any abnormal changes in gain versus frequency on Data Sheet 2-2. The gain should be constant ( $\pm 1$  dB) within the passband of a well-designed amplifier. Continue tuning until response drops approximately 10 dB to ensure that the actual amplifier band edges have been reached. Readjust the signal generator and record the  $-3$ -dB points on Data Sheet 2-2.
6. Record the data on Data Sheet 2-2 at convenient frequency increments across the band by manually tuning the generator across the band, being careful to record all abnormal gain changes that may occur.
7. The same results are obtained using a wide-band noise source or sweep generator in place of the signal generator.

 <b>NOTE</b>	If the sweep generator or noise source does not have an automatic level control, the level variation versus frequency must be compensated and the data corrected for these variations.
---	--

8. Set the variable voltage supply to the highest normal operating voltage for which the amplifier is designed. Repeat steps 1 through 6.
9. Set the variable voltage supply to the lowest voltage specified for the amplifier. Repeat steps 1 through 6.
10. Set up the equipment in an environmental chamber and operate the amplifier at the highest temperature for which it is designed. Repeat steps 1 through 6.
11. Set up the equipment in an environmental chamber and operate the amplifier at the lowest temperature for which it is designed. Repeat steps 1 through 6.

Data Sheet 2-2. Telemetry RF Preamplifiers					
Test 2.2		Bandwidth and small-signal power gain including temperature and supply voltage variations			
Manufacturer:			Model:		Serial No.:
Test Personnel:					Date:
Amplifier gain determined in Subsection <a href="#">2.2.5</a> step 3					
Standard Conditions		Supply Voltage Variation		Temperature Variation	
Frequency (MHz)	Gain (dB)	Gain Low Supply Voltage (dB)	Gain High Supply Voltage (dB)	Gain High Temp. (dB)	Gain Low Temp. (dB)
Lower 3-dB point (MHz)					
Upper 3-dB point (MHz)					

	<p><b>NOTE</b> This value should agree with the value determined in Test <a href="#">2.1</a>, thereby verifying that the equipment is set up properly.</p>
---	--

2.2.6 Data Reduction. Plot (or photograph) the data as shown in [Figure 2-4](#) to determine power gain and bandwidth.

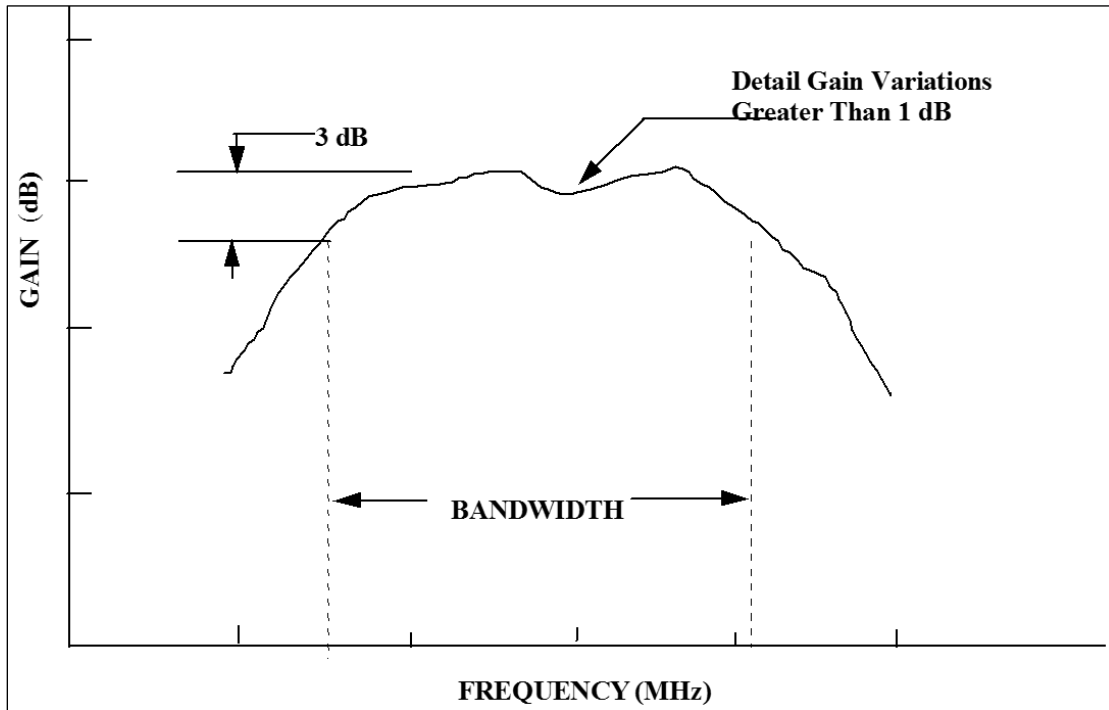

Figure 2-4. Plot of Power Gain and Bandwidth versus Frequency

### 2.3. TEST: Amplifier IM Products and Intercept Point

2.3.1 Purpose. This test measures the IM products and IP of an amplifier. See [Appendix A](#) for IM product determination and the IP of an amplifier.

2.3.2 Test Equipment. Two signal generators, isolator, spectrum analyzer, and termination (characteristic impedance).

2.3.3 Setup. Connect the test equipment as shown in [Figure 2-5](#).

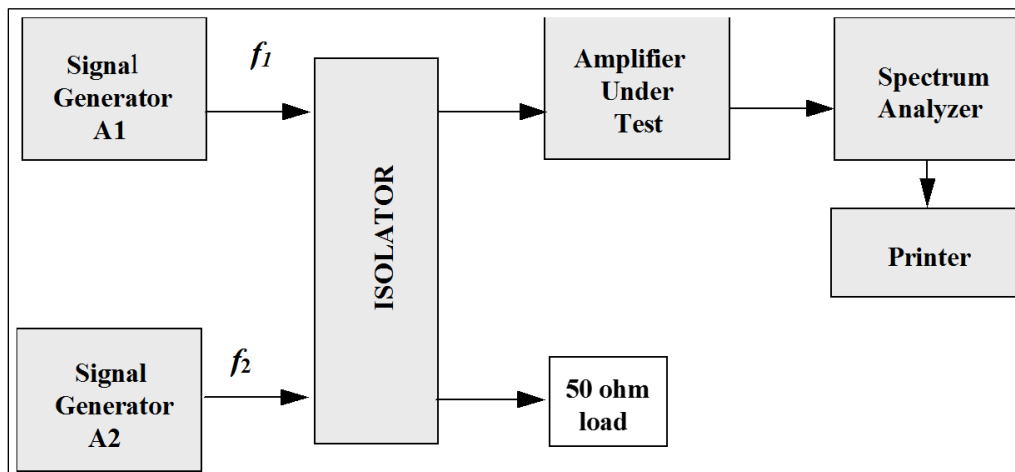
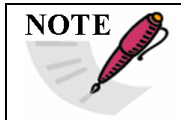

Figure 2-5. Test Setup for Determination of Intercept Point

2.3.4 Conditions. Perform this test under laboratory conditions after a warm-up time of at least 30 minutes.

 <b>NOTE</b>	The IP technique is generally accepted as the best approach for describing the overload characteristics of an amplifier. See <a href="#">Appendix A</a> for details on the IP technique.
---	--

2.3.5 Procedure

1. Set the fundamental signals  $f_1$  and  $f_2$  near the mid-band frequency of the amplifier under test. The spacing of the fundamental signals is not critical as long as the third-order products are within the amplifier passband, which must be greater than  $3(f_2 - f_1)$ .
2. Set each of the calibrated signal generator attenuators ( $A_1$  and  $A_2$ ) to a convenient reference level, for example,  $-50$  dBm. Connect the spectrum analyzer to the isolator and observe the spectrum; only  $f_1$  and  $f_2$  should appear. Increase the output power of both signal generators 10 dB by adjusting  $A_1$  and  $A_2$  equally and verify that the displayed signals increase by 10 dB. This technique ensures that the IM products are not being produced in the isolator or spectrum analyzer.

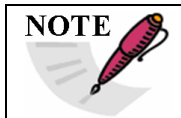
 <b>NOTE</b>	Spectrum analyzers may produce IM products when a high-level signal is applied to the first mixer. Refer to the spectrum analyzer instruction manual. An attenuator may not be needed at the analyzer input.
---	--

3. Reconnect the preamplifier between the isolator and the spectrum analyzer. The amplifier output will be equal to the signal generator output levels (keeping  $A_1$  and  $A_2$  equal) minus the isolator and cable losses plus the amplifier gain.

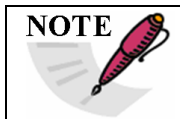
 <b>NOTE</b>	The more attenuation inserted between generators, the greater the isolation. This increased isolation reduces the possibility of IM between signal generators.
---	--

4. Set the power output to the preamplifier to a convenient power level such that the amplifier is not saturated. Adjust the display device so that the amplitudes of  $f_1$  and  $f_2$  equal a convenient reference level. Adjust the display width to include the two fundamentals and the two third-order IM products as shown in [Figure 2-6](#).

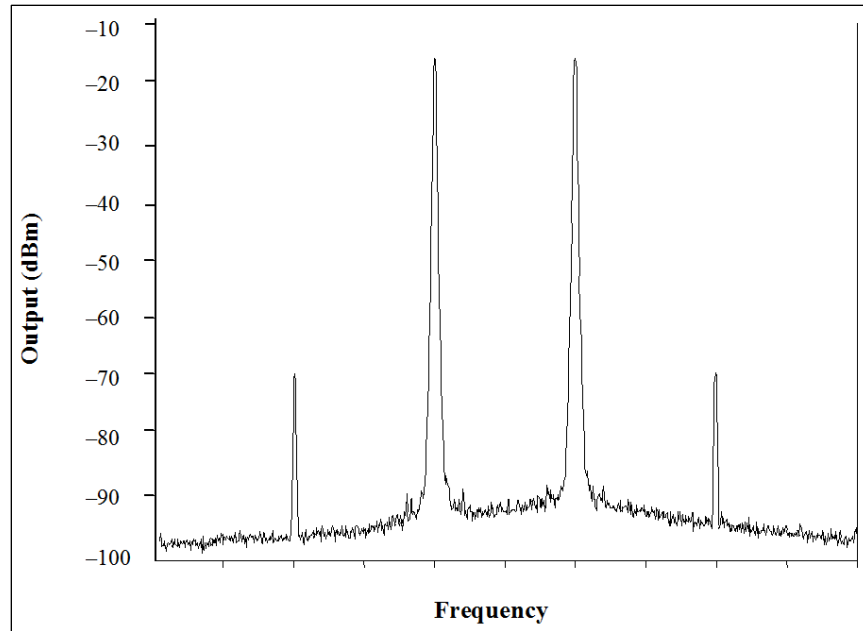

Figure 2-6. Typical Display of Fundamental and Third-Order IM Products

5. Record in dBm the magnitude of the fundamental and the highest third-order IM product. Record in dBm the fundamental input power on Data Sheet 2-3.
6. Reduce the input to the amplifier in convenient steps (keeping  $A_1$  and  $A_2$  equal) and repeat step 5. Continue to reduce the input until the third-order IM products decrease to the noise floor (see [Figure 2-6](#)).

### 2.3.6 Data Reduction

1. Plot the magnitude of the fundamental and third-order IM products versus the input power. Plot both quantities in dBm on linear paper. Extend the lines of each plot, as illustrated in [Figure 2-7](#), until they intersect. This is the intersection of the third-order IP.



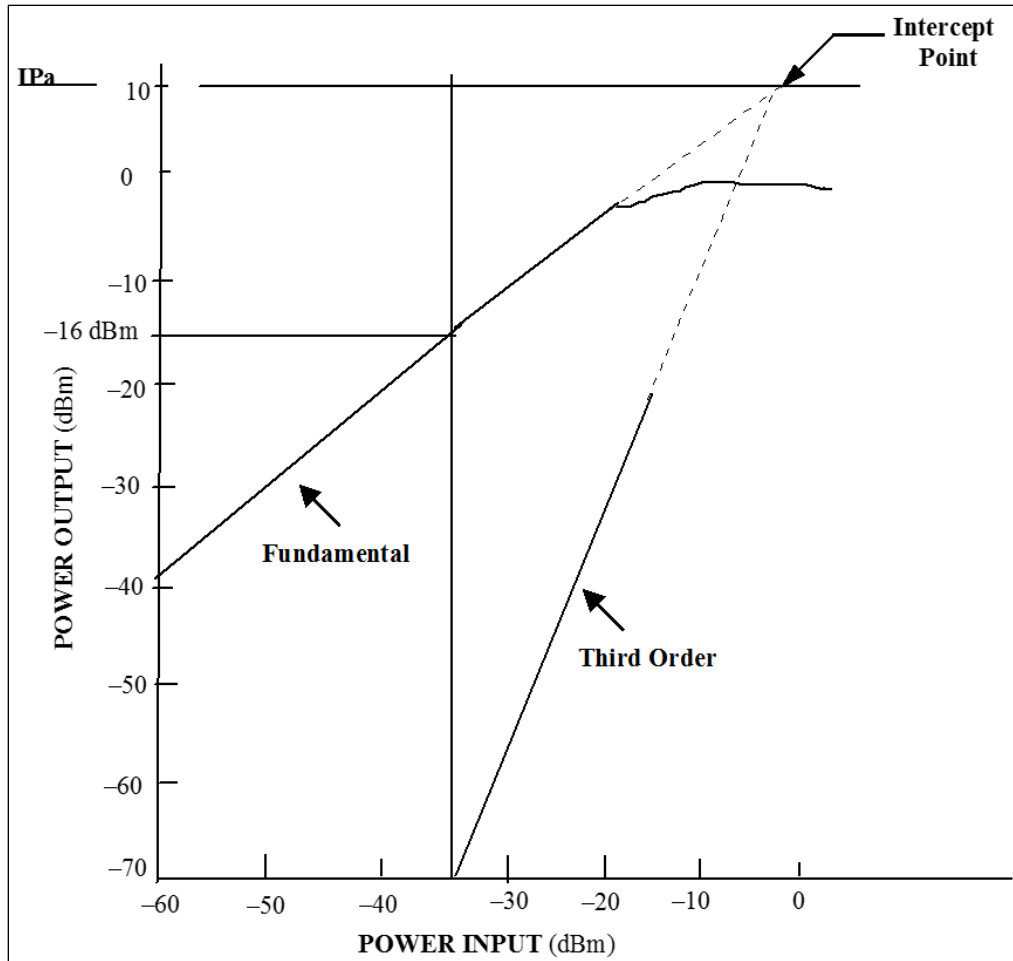

Figure 2-7. Graphical Illustration of Intercept Point

2. When the amplifier third-order output IP ( $IP_0$ ) has been experimentally determined, the small-signal performance of a given amplifier, having two equal-amplitude signals present in the passband simultaneously, can be resolved from a graphical representation as illustrated in [Figure 2-7](#).
  - a. As an example, the graphical solution in [Figure 2-7](#) shows that the third-order output IP is +10 dBm. Find the third-order IM product for an output signal level of -16 dBm. Draw a vertical line through the -16-dBm point on the fundamental signal line and extend this line until it intersects the third-order IM line. Read approximately -70 dBm on the third-order output scale.
  - b. When the IP is known, the third-order IM products for any fundamental signal output can be determined from the following equation:

$$\text{Power output of the third-order products} = IP - 3 (IP_0 - \text{fundamental output power}) \text{ dB}$$

Then using the numbers from data reduction step 2.a and [Figure 2-7](#),

$$\text{Third-Order Output} = 10 - 3 [(10) - (-16)] \text{ dBm} = -68 \text{ dBm}$$

Data Sheet 2-3. Telemetry RF Preamplifiers				
Test 2.3		Intermodulation products and intercept point		
Manufacturer:		Model:	Serial No:	
Test personnel:			Date:	
Frequency $f_1$ MHz _____ Frequency $f_2$ MHz _____				
Fundamental Input Power (dBm)	Fundamental Output Power (dBm)	Third-Order Output Power (dBm)	Difference Third-Order and Output (dBm)	Second-Order Output Power (dBm)

 <p><b>NOTE</b></p>	Amplifiers with passbands greater than one octave may have second-order IM terms present that should be recorded and plotted (see <a href="#">Appendix A</a> ).
--	---

3. A spurious response nomograph (see [Figure 2-8](#)) can be used instead of the graphical representation to determine the small-signal performance of a given amplifier when the output IP is known or determined experimentally from data reduction step 1.

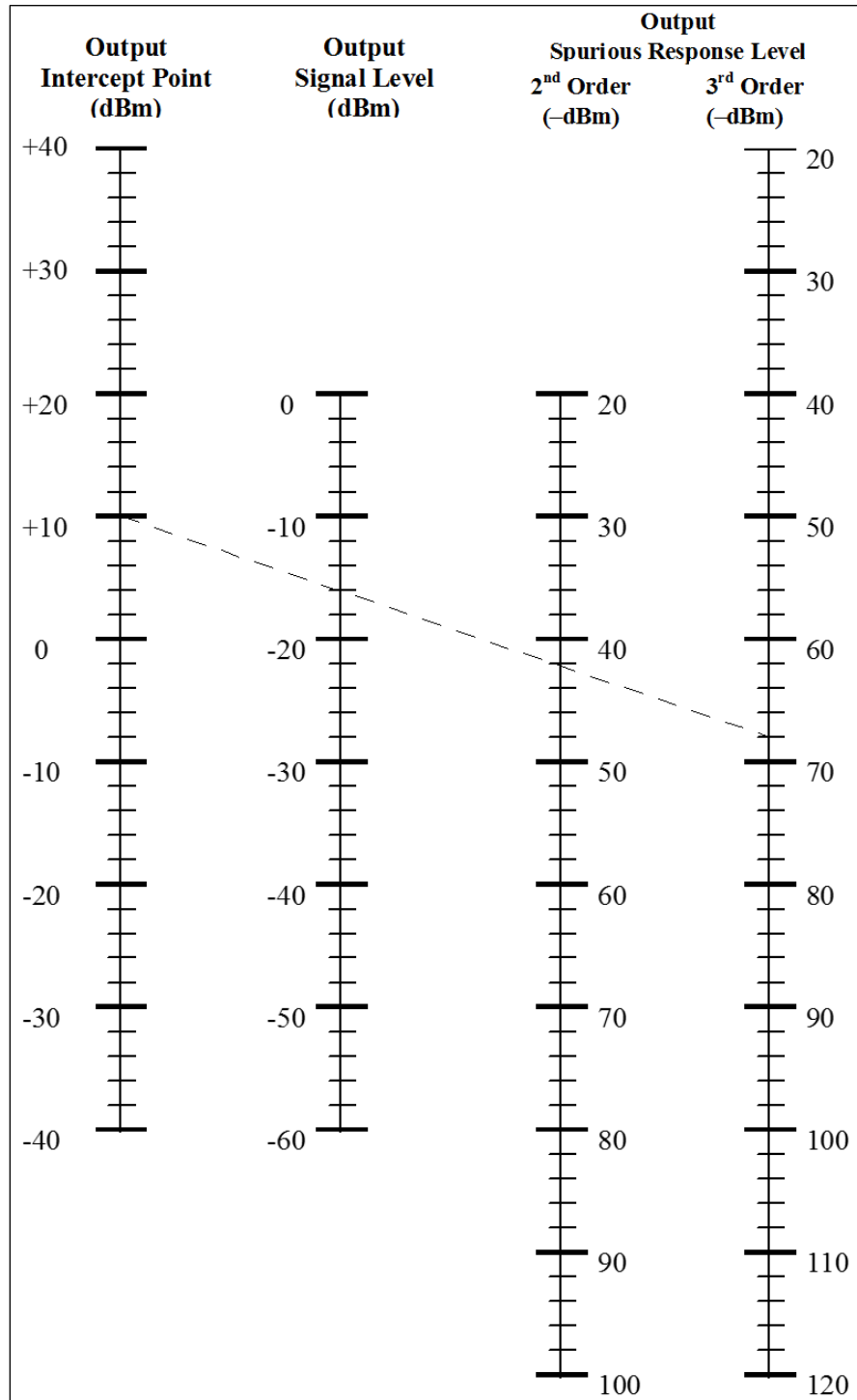

Figure 2-8. Spurious Response Nomograph

- a. Place a straight edge on the +10 dBm output IP and at -16 dBm on the fundamental output point.
- b. Read -68 dBm on the third-order spurious response line.

## 2.4. TEST: Amplifier VSWR by Return Loss Method

2.4.1 Purpose. This test determines the quality of the impedance match of the device under test by measuring the VSWR using the return loss method. The test method illustrated here is for a spectrum analyzer; however, a network analyzer could be used.

2.4.2 Test Equipment. Signal generator, 20-dB directional coupler, spectrum analyzer, termination (characteristic impedance), and RF short.

2.4.3 Setup. Connect the test equipment as shown in [Figure 2-9](#).

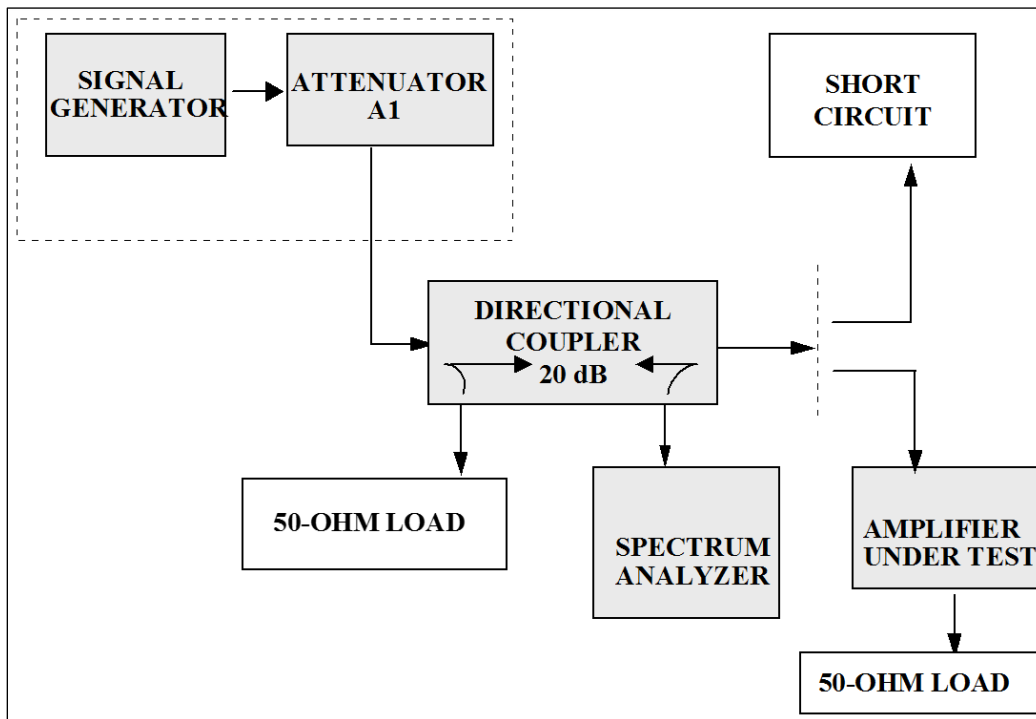
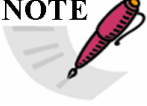



Figure 2-9. Test Setup for Measurement of Return Loss (VSWR)

2.4.4 Conditions. Perform this test under laboratory conditions after a warm-up time of at least 30 minutes. All procedures are conducted with continuous wave signals (unmodulated) into the device under test. Variations in operating temperature will be evaluated.

<p><b>NOTE</b></p> 	<p>Because the VSWR is a measure of the mismatch between the load and the line, it is possible to measure the voltage reflected from a load to a transmission line with a directional coupler. If the load is replaced by a short circuit whose reflection coefficient is unity (a short circuit reflects all the incident power), the reflected voltage measured through the directional coupler will be increased. The return loss is defined as the ratio of the voltage reflected from the short circuit to the voltage reflected from the load while keeping the input signal constant.</p>
--	--

#### 2.4.5 Procedure

1. Set the generator frequency to the mid-band frequency of the amplifier to be tested and adjust the calibrated attenuator for a level of about  $-40$  dBm into the directional coupler.

 <b>NOTE</b>	The input level should be at least 10 dB less than the 1-dB compression point obtained in Test <a href="#">2.1</a> .
---	--

2. Connect the short circuit termination to the coupler and establish a convenient reference level on the spectrum analyzer. A 0-dB reference is very convenient to use with the spectrum analyzer set for a log display.
3. Remove the short circuit termination and connect the amplifier input to the directional coupler. Terminate the amplifier output port with its specified impedance load. Observe the signal level on the spectrum analyzer. The difference between the reference level established in step 2 and the new level observed in dB is the return loss.
4. Tune the signal generator across the band pass of the amplifier under test. Record the return loss in dB at convenient increments across the band on Data Sheet 2-4. Note and record any abnormal changes in return loss versus frequency as the generator is tuned.
5. Reverse the amplifier connection in the test setup and repeat steps 2 through 4 to obtain the amplifier output return loss.
6. Repeat steps 2 through 5 at high and low operating temperatures.

**Data Sheet 2-4. Telemetry RF Preamplifiers**

<b>Test 2.4</b>	<b>VSWR by return to loss method including temperature variations</b>	
<b>Manufacturer:</b>	<b>Model:</b>	<b>Serial No.:</b>
<b>Test Personnel:</b>		<b>Date:</b>

Frequency (MHz)	Input Return Loss (dB)		Input VSWR (Table 2-2 or Calculation)		Output Return Loss (dB)		Output VSWR (Table 2-2 or Calculation)	
	Test 2.4	Test 2.4	Test 2.4	Test 2.4	Test 2.4	Test 2.4	Test 2.4	Test 2.4
		Temp.		Temp.		Temp.		Temp.

#### 2.4.6 Data Reduction

1. Convert the return loss data to equivalent VSWR by using the dB-to-VSWR values shown in [Table 2-2](#).

<b>Table 2-2. Return Loss to Equivalent VSWR</b>							
<b>dB</b>	<b>VSWR</b>	<b>dB</b>	<b>VSWR</b>	<b>dB</b>	<b>VSWR</b>	<b>dB</b>	<b>VSWR</b>
0		8	2.32	17	1.33	26	1.11
.5	34.75	9	2.10	18	1.29	27	1.09
1	17.39	10	1.92	19	1.25	28	1.08
2	8.72	11	1.78	20	1.22	29	1.07
3	5.85	12	1.67	21	1.20	31	1.06
4	4.42	13	1.58	22	1.17	32	1.05
5	3.57	14	1.50	23	1.15	34	1.04
6	3.01	15	1.43	24	1.13	37	1.03
7	2.61	16	1.38	25	1.12	40	1.02

2. Calculate VSWR from the return loss, measured in dB, from equations 2-2, 2-3, and 2-4:

$$L_R = 20 \cdot \log (1 / \rho) \quad (\text{Eq. 2-2})$$

$$\rho = 1 / \text{antilog} (L_R/20) \quad (\text{Eq. 2-3})$$

$$\text{VSWR} = \frac{1 + \rho}{1 - \rho} \quad (\text{Eq. 2-4})$$

Where:

$\rho$  = reflection coefficient of load being measured

$L_R$  = return loss measured

Example:

$$L_R = 1$$

$$\rho = 0.89125$$

$$\text{VSWR} = \frac{1 + \rho}{1 - \rho} = \frac{1.89125}{0.10875} = 17.39$$

## 2.5. TEST: Noise Figure using Automatic Noise Figure Meter

2.5.1 Purpose. This test measures the noise figure of an amplifier. Noise figure is defined as the ratio (expressed in dB) of the total output noise power per unit bandwidth at a given output frequency when the noise temperature of the input termination is 290 K to that portion of the output power (same frequency and bandwidth) because of the input termination. See [Appendix B](#) for a discussion of noise figure.

2.5.2 Test Equipment. Noise figure meter and noise source.

2.5.3 Test Method. This test measures noise figure using a calibrated noise source and an automatic noise figure meter.

2.5.4 Setup. Connect the test equipment as shown in [Figure 2-10](#).

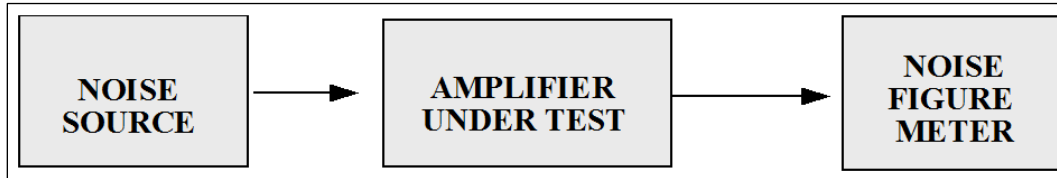
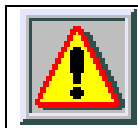

Figure 2-10. Noise Figure using Automatic Noise Figure Meter

2.5.5 Conditions. Perform this test under laboratory conditions after the specified warm-up time. Carefully follow operating procedures and cautions in noise figure operation manual. If the noise figure meter does not operate at the amplifier frequency, external frequency translation will be required. The noise figure operation manual will contain recommendations on how to do this translation. Alternate test configurations are shown in test methods [2.6](#), [3.5](#), and [4.2](#).



Field effect transistor amplifiers can be damaged by noise spikes.

2.5.6 Procedure

1. Calibrate noise figure meter using method recommended in the manual.
2. Reconnect test equipment as shown in [Figure 2-10](#). Measure the noise figure in 10-MHz steps. Record these values on Data Sheet 2-5.
3. Find the maximum noise figure by varying the measurement frequency across the band. Record the frequency and noise figure on Data Sheet 2-5.

2.5.7 Data Reduction. Compare the measured values to the specification.



<b>Data Sheet 2-5. Telemetry Preamplifiers</b>																																														
<b>Test 2.5</b>	<b>Noise figure using automatic noise figure meter</b>																																													
<b>Manufacturer:</b>		<b>Model:</b>																																												
<b>Serial No.:</b>		<b>Frequency range:</b>																																												
<b>Test Personnel:</b>	<b>Date:</b>	<b>Location:</b>																																												
<table border="1"> <thead> <tr> <th>Measurement frequency (MHz)</th> <th>Noise Figure (dB)</th> </tr> </thead> <tbody> <tr><td> </td><td> </td></tr> <tr><td> </td><td> </td></tr> <tr><td> </td><td> </td></tr> <tr><td> </td><td> </td></tr> <tr><td> </td><td> </td></tr> <tr><td> </td><td> </td></tr> <tr><td> </td><td> </td></tr> <tr><td> </td><td> </td></tr> <tr><td> </td><td> </td></tr> <tr><td> </td><td> </td></tr> <tr><td> </td><td> </td></tr> <tr><td> </td><td> </td></tr> <tr><td> </td><td> </td></tr> <tr><td> </td><td> </td></tr> <tr><td> </td><td> </td></tr> <tr><td> </td><td> </td></tr> <tr><td> </td><td> </td></tr> <tr><td> </td><td> </td></tr> <tr><td> </td><td> </td></tr> <tr><td> </td><td> </td></tr> <tr><td> </td><td> </td></tr> </tbody> </table>			Measurement frequency (MHz)	Noise Figure (dB)																																										
Measurement frequency (MHz)	Noise Figure (dB)																																													

## 2.6. TEST: Impedance Mismatch

2.6.1 Purpose. This test measures the effect of impedance mismatch on the stability of a TM amplifier.

2.6.2 Test Equipment. Calibrated mismatch terminations, line stretcher, and spectrum analyzer.

2.6.3 Test Method. This test inserts a known calibrated mismatch at the preamplifier input. The amplifier output is monitored with a spectrum analyzer to detect any spurious signals.

2.6.4 Setup. Connect the test equipment as shown in [Figure 2-11](#).

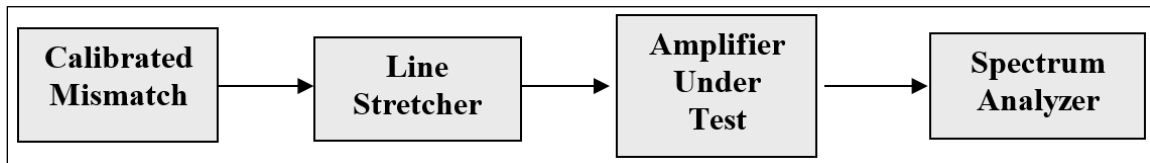

Figure 2-11. Impedance Mismatch Test Setup

2.6.5 Conditions. Perform this test under laboratory conditions after the specified warm-up time.

### 2.6.6 Procedure

1. Connect the calibrated mismatch that represents the maximum input VSWR specified by the manufacturer to the amplifier input and vary the line stretcher over the full length.
2. Observe the spectrum analyzer for spurious signals and record the level and frequency on Data Sheet 2-6.

<b>Data Sheet 2-6. Telemetry RF Preamplifiers</b>																																						
<b>Test 2.6</b>	<b>Impedance mismatch</b>																																					
<b>Amplifier Manufacturer:</b>	<b>Model:</b>																																					
<b>Serial No.:</b>	<b>Frequency range:</b>																																					
<b>Test Personnel:</b>	<b>Date:</b>	<b>Location</b>																																				
<table border="1"><thead><tr><th colspan="2">Spurious Signals</th></tr><tr><th>Frequency (MHz)</th><th>Power (dBm)</th></tr></thead><tbody><tr><td> </td><td> </td></tr><tr><td> </td><td> </td></tr><tr><td> </td><td> </td></tr><tr><td> </td><td> </td></tr><tr><td> </td><td> </td></tr><tr><td> </td><td> </td></tr><tr><td> </td><td> </td></tr><tr><td> </td><td> </td></tr><tr><td> </td><td> </td></tr><tr><td> </td><td> </td></tr><tr><td> </td><td> </td></tr><tr><td> </td><td> </td></tr><tr><td> </td><td> </td></tr><tr><td> </td><td> </td></tr><tr><td> </td><td> </td></tr><tr><td> </td><td> </td></tr></tbody></table>			Spurious Signals		Frequency (MHz)	Power (dBm)																																
Spurious Signals																																						
Frequency (MHz)	Power (dBm)																																					

This page intentionally left blank.

## CHAPTER 3

### Test Procedures for Telemetry Multicouplers

#### 3. General

This chapter describes the test procedures used to measure the parameters of TM multicouplers. For these test procedures, a multicoupler is defined as a single input, multiple output RF device. There are methods for determining the range of linear operation by measuring gain compression, bandwidth, and small-signal power gain including gain variations because of temperature and supply voltage, IM products and IP, VSWR, noise figure, and output isolation. Unless otherwise noted, it is assumed that multicoupler control and power supply inputs are applied as needed. [Table 3-1](#) lists the types of tests and their test and paragraph number.

Table 3-1. Test Matrix for TM Multicouplers	
Test Number	Test Description
<a href="#">3.1</a>	Multicoupler gain compression
<a href="#">3.2</a>	Bandwidth and small-signal power gain
<a href="#">3.3</a>	IM products IP
<a href="#">3.4</a>	VSWR by return loss method
<a href="#">3.5</a>	Noise figure
<a href="#">3.6</a>	Output isolation

#### 3.1. TEST: Multicoupler Gain Compression

3.1.1 Purpose. This test measures the 1-dB compression point that is defined as the point where the gain of a multicoupler has been decreased 1 dB from the small-signal gain. The 1-dB compression point can be used to define the upper limit of the multicoupler linear range.

3.1.2 Test Equipment. Signal generator, spectrum analyzer, attenuator, and terminations (characteristic impedance).

3.1.3 Setup. Connect the test equipment as shown in [Figure 3-1](#).

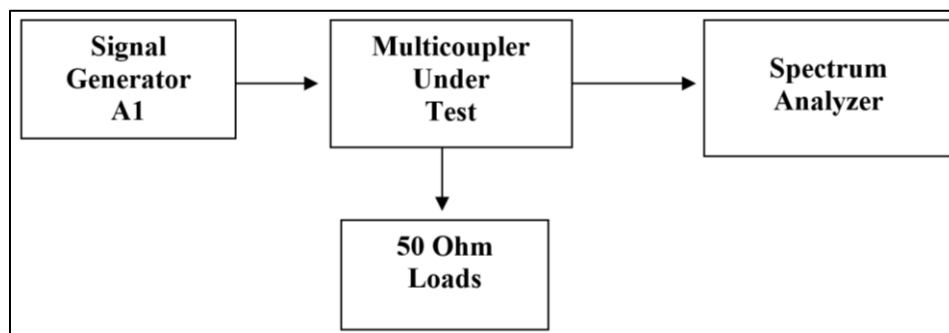

Figure 3-1. Test Setup for Measurement of Multicoupler Gain Compression Level

3.1.4 Conditions. Perform this test under laboratory conditions after a warm-up time of at least 30 minutes. All procedures are conducted with continuous wave signals (unmodulated) into the device under test. Variations in supply voltage will be evaluated.

### 3.1.5 Procedure

1. Remove the multicoupler under test from the setup shown in [Figure 3-1](#). Set the signal generator frequency to the center of the passband and set the generator attenuator  $A_1$  to a value at least 30 dB below the specified gain compression level of the multicoupler. Adjust attenuator  $A_1$  to a convenient reference level on the analyzer. Record attenuator  $A_1$  initial settings on Data Sheet 3-1.



Do not exceed the amplifier manufacturer's maximum recommended input power because permanent damage to the amplifier may result.

2. Connect the multicoupler between the signal generator and the spectrum analyzer as illustrated in [Figure 3-1](#). Vary attenuator  $A_1$  to return the signal level on the analyzer to the reference level. Record the change in  $A_1$  on Data Sheet 3-1. To ensure that the multicoupler is operating in its linear range, increase the signal generator level an additional 3 dB and verify that the spectrum analyzer level increases 3 dB. If the level does not increase, reduce the signal generator  $A_1$  about 10 dB and repeat the steps above. Record  $A_1$  and the final settings on Data Sheet 3-1.
3. Increase input power at convenient signal generator attenuator  $A_1$  steps.
4. Record spectrum analyzer readings and signal generator power levels on Data Sheet 3-1.

3.1.6 Data Reduction. Plot multicoupler output power versus input power and note where the output level decreases 1 dB from the linear extrapolation of multicoupler response as illustrated in [Figure 3-2](#). This is the multicoupler gain compression level. Record the input/output gain compression level on Data Sheet 3-1.

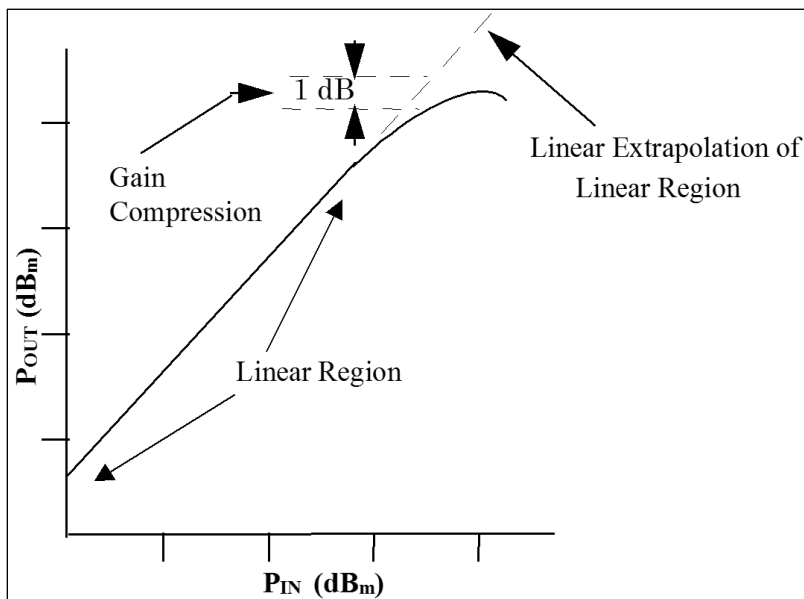

Figure 3-2. Multicoupler Gain Compression

Data Sheet 3-1. Telemetry Multicouplers																														
<b>Test 3.1</b>	<b>Multicoupler gain compression</b>																													
<b>Amplifier Manufacturer:</b>	<b>Model:</b>																													
<b>Serial No.:</b>	<b>Frequency range:</b>																													
<b>Test Personnel:</b>	<b>Date:</b>	<b>Location:</b>																												
Multicoupler gain determined in Subsection <a href="#">3.1.5</a> step 2																														
<table border="1" style="width: 100%; border-collapse: collapse;"> <thead> <tr> <th style="width: 50%; padding: 5px;">RF Input Power (<math>A_1</math>) (dBm)</th> <th style="width: 50%; padding: 5px;">Power Output (dBm)</th> </tr> </thead> <tbody> <tr><td style="height: 20px;"> </td><td> </td></tr> <tr><td style="height: 20px;"> </td><td> </td></tr> <tr><td style="height: 20px;"> </td><td> </td></tr> <tr><td style="height: 20px;"> </td><td> </td></tr> <tr><td style="height: 20px;"> </td><td> </td></tr> <tr><td style="height: 20px;"> </td><td> </td></tr> <tr><td style="height: 20px;"> </td><td> </td></tr> <tr><td style="height: 20px;"> </td><td> </td></tr> <tr><td style="height: 20px;"> </td><td> </td></tr> <tr><td style="height: 20px;"> </td><td> </td></tr> <tr><td style="height: 20px;"> </td><td> </td></tr> <tr><td style="height: 20px;"> </td><td> </td></tr> <tr><td style="height: 20px;"> </td><td> </td></tr> </tbody> </table>			RF Input Power ( $A_1$ ) (dBm)	Power Output (dBm)																										
RF Input Power ( $A_1$ ) (dBm)	Power Output (dBm)																													
Test frequency: _____ 1-dB compression point: $P_o$ _____ dBm $P_i$ _____ dBm Take additional readings where data slope changes abruptly.																														

### 3.2. TEST: Bandwidth and Small-signal Power Gain

3.2.1 Purpose. This test measures the bandwidth that is defined as the range of frequencies over which the amplitude response does not decrease more than 3 dB from the highest point over the specified frequency band of the device under test. The multicoupler small-signal power gain is the ratio of output power to input power in the linear operating range and is generally expressed in dB (assuming the impedance of the input/output circuits are properly matched). This gain is expressed by equation 3-2.

$$Gain = 10 \cdot \log_{10} (P_{out}/P_{in}) \text{ dB} \quad (\text{Eq. 3-1})$$

or

$$Gain = 10 \cdot \log_{10} (P_{out}) - 10 \cdot \log_{10} (P_{in}) \text{ dB} \quad (\text{Eq. 3-2})$$

3.2.2 Test Equipment. Signal generator, spectrum analyzer, sweep oscillator, attenuator, terminations (characteristic impedance), and ac or dc variable voltage supply.

3.2.3 Setup. Connect the test equipment as shown in [Figure 3-3](#). (Either method illustrated is acceptable.)

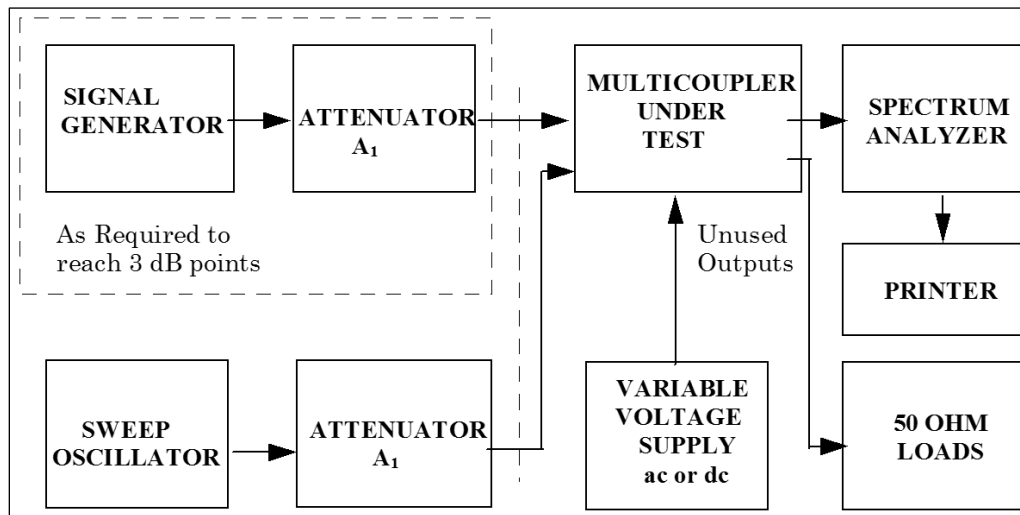

Figure 3-3. Test Setup for Measurement of Bandwidth and Small-signal Power Gain

3.2.4 Conditions. Perform this test under laboratory conditions after a warm-up time of at least 30 minutes. All procedures are conducted with continuous wave signals (unmodulated) into the device under test. Variations in supply voltage will be evaluated.

#### 3.2.5 Procedure

1. Set the signal generator frequency to the center of the passband for the device under test.
2. Set the attenuator A<sub>1</sub> to provide a multicoupler output at the spectrum analyzer at least 10 dB below the 1-dB compression level of the multicoupler as determined in Test [3.1](#).



- Adjust the spectrum analyzer to display the frequency line in the linear operating range at a convenient reference level on the log scale such as 0 dB. The spectrum analyzer vertical display must be operating in the log mode. Record the attenuator setting and analyzer level on Data Sheet 3-2.
- Disconnect the multicoupler and connect the analyzer to the attenuator. Record in dB the difference between the signal now displayed and the reference level in step 3 as the gain of the multicoupler.

 <b>NOTE</b>	This value should agree with the value determined in Test <a href="#">3.1</a> verifying that the equipment is set up properly.
---	--

- Reconnect the multicoupler ([Figure 3-3](#)) and tune across the band. Note and record any abnormal changes in gain versus frequency on Data Sheet 3-2. The gain should be constant ( $\pm 1$  dB) within the passband of a well-designed multicoupler. Continue tuning until response drops approximately 10 dB to ensure that the actual multicoupler band edges have been reached. Record the  $-10$  dB point on Data Sheet 3-2. Readjust the signal generator frequency and record the  $-3$ -dB points on Data Sheet 3-2. Repeat this measurement for the other band edge.
- Record the data on the data sheet at convenient frequency increments across the band by manually tuning the generator across the band, being careful to record all abnormal gain changes that may occur.
- The same results are obtained using a wide-band noise source or sweep generator in place of the signal generator.

 <b>NOTE</b>	If the sweep generator or noise source does not have an automatic level control, the level variation versus frequency must be compensated and the data corrected for these variations.
---	--

- Set the variable voltage supply to the highest normal operating voltage for which the multicoupler is designed. Repeat steps 1 through 6.
- Set the variable voltage supply to the lowest voltage specified for the multicoupler. Repeat steps 1 through 6.
- Set up the equipment in an environmental chamber and operate the multicoupler at the highest temperature for which it is designed. Repeat steps 1 through 6.
- Set up the equipment in an environmental chamber and operate the multicoupler at the lowest temperature for which it is designed. Repeat steps 1 through 6.

Data Sheet 3-2.     Telemetry Multicouplers					
Test 3.2		<b>Bandwidth and small-signal power gain including temperature and supply voltage variations</b>			
<b>Amplifier Manufacturer:</b>			<b>Model:</b>		
<b>Serial No.:</b>					
<b>Test Personnel:</b>			<b>Date:</b>		
<b>Initial conditions:</b>		<b>Analyzer level</b>			
<b>Attenuator setting</b>					
Multicoupler gain determined in Subsection <a href="#">3.2.5</a> step 4					
Standard Conditions		Supply Voltage Variation		Temperature Variation	
Frequency (MHz)	Gain (dB)	Gain High Supply Voltage (dB)	Gain Low Supply Voltage (dB)	Gain High Temp. (dB)	Gain Low Temp. (dB)
Lower 10-dB Point (MHz)					
Lower 3-dB Point (MHz)					
Upper 3-dB Point (MHz)					
Upper 10-dB Point (MHz)					

3.2.6 **Data Reduction.** Plot (or photograph) the data as shown in [Figure 3-4](#) to determine power gain and bandwidth.

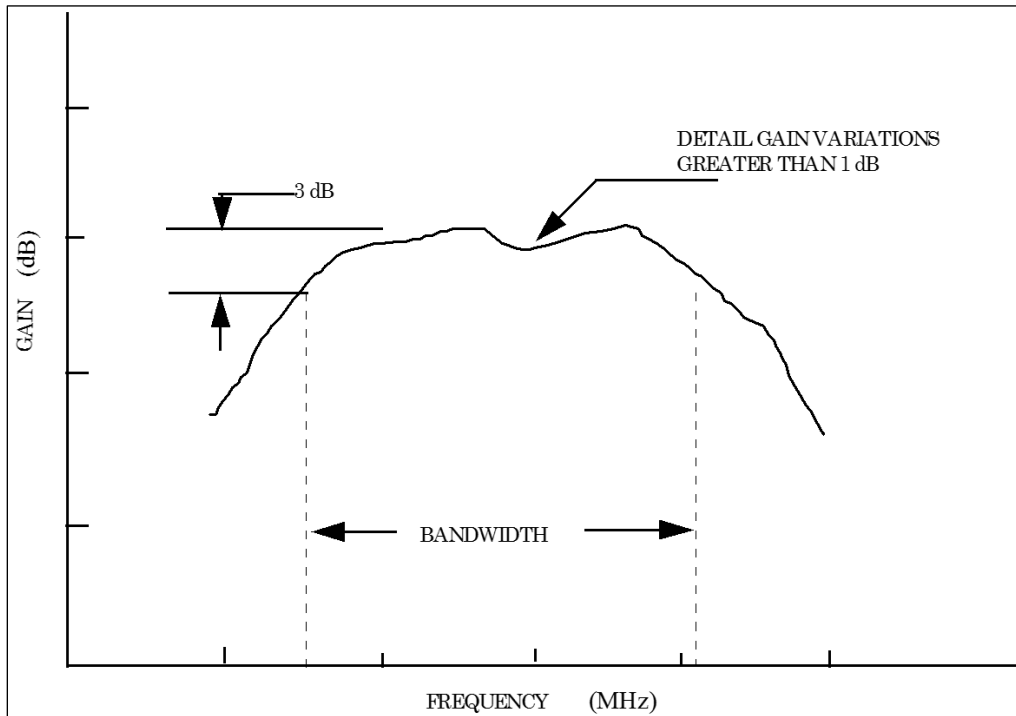

Figure 3-4. Plot of Power Gain and Bandwidth versus Frequency

### 3.3. TEST: Multicoupler IM Products and Intercept Point

3.3.1 **Purpose.** This test measures the IM products and IP of a multicoupler. The IM products are generated whenever two or more signals are input to an active device. Products of high-level input signals can obscure desired output signals. Usually, third-order products are the only interfering signals of concern; however, higher products may affect reception of very low-level signals in wide-band systems. The intercept point is a figure of merit for evaluating the dynamic range of active devices and determining product output power. See data reduction step 2.b for an example of calculation of third-order product power. See [Appendix A](#) for a discussion of IM products and IP.

3.3.2 **Test Equipment.** Two signal generators, isolator, spectrum analyzer, and termination (characteristic impedance).

3.3.3 **Setup.** Connect the test equipment as shown in [Figure 3-5](#).

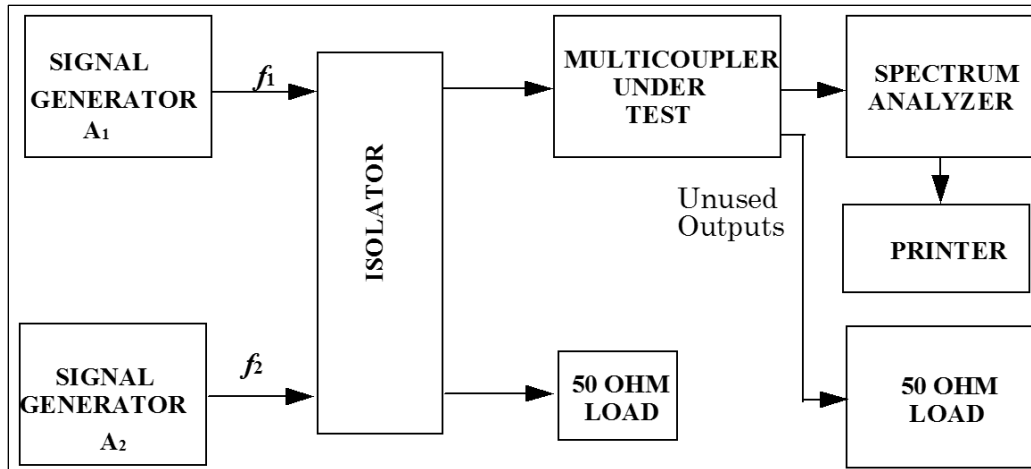



Figure 3-5. Test Setup for Determination of Intercept Point

3.3.4 **Conditions.** Perform this test under laboratory conditions after a warm-up time of at least 30 minutes. All procedures are conducted with continuous wave signals (unmodulated) into the device under test.

 <p><b>NOTE</b></p>	<p>The IP technique is generally accepted as the best approach for describing the overload characteristics of a multicoupler. See <a href="#">Appendix A</a> for details on the IP technique.</p>
--	---

### 3.3.5 Procedure

1. Set the fundamental signals  $f_1$  and  $f_2$  near the mid-band frequency of the multicoupler under test. The spacing of the fundamental signals is not critical as long as the third-order products are within the multicoupler passband, which must be greater than  $3(f_2 - f_1)$ .
2. Set each of the calibrated signal generator attenuators ( $A_1$  and  $A_2$ ) to a convenient reference level, for example,  $-50$  dBm. Connect the spectrum analyzer to the hybrid output and observe the spectrum. Only  $f_1$  and  $f_2$  should appear. Increase the output power of both signal generators 10 dB by adjusting  $A_1$  and  $A_2$  equally, and verify that the displayed signals increase by 10 dB. This technique ensures that the IM products are not being produced in the hybrid or spectrum analyzer.

 <p><b>NOTE</b></p>	<p>Spectrum analyzers may produce IM products when a high-level signal is applied to first mixer. Refer to the spectrum analyzer instruction manual. An attenuator may be needed at the analyzer input.</p>
--	---

3. Reconnect the multicoupler between the isolator and the spectrum analyzer. With the isolator, the multicoupler output will be equal to the signal generator output power levels (keeping  $A_1$  and  $A_2$  equal) plus the multicoupler gain. Increase the output power of both signal generators (keeping  $A_1$  and  $A_2$  equal) and verify that the output of the multicoupler is within the linear operating region (see [Figure 3-2](#)).

 <p><b>NOTE</b></p>	<p>The more attenuation inserted between generators, the greater the isolation. This increased isolation reduces the possibility of IM between signal generators.</p>
--	---

4. Set the power input to the input of the multicoupler to  $-20$  dBm. Adjust the display device so that the amplitudes of  $f_1$  and  $f_2$  are equal to a convenient reference level. Adjust the display width to include the two fundamentals and the two third-order IM products as shown in [Figure 3-6](#).

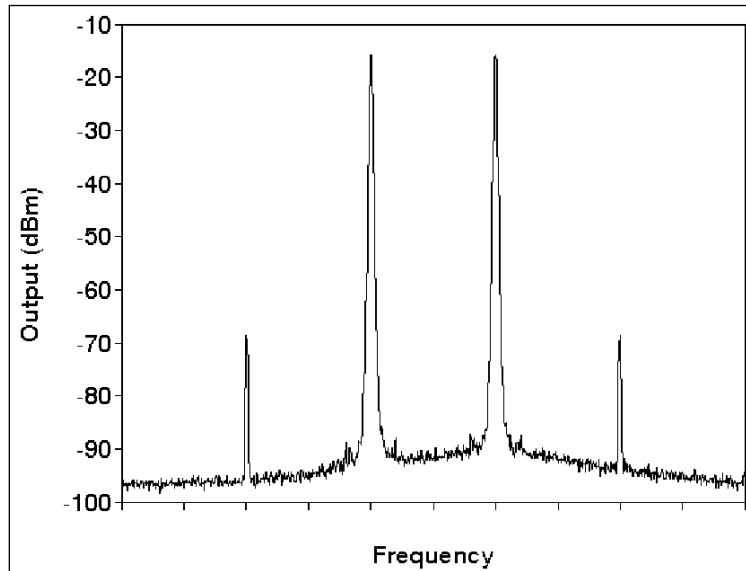

Figure 3-6. Typical Display of Fundamental and Third-Order IM Products

5. Record in dB the difference in magnitude between the fundamental and the third-order IM products. Record in dBm the fundamental input power on Data Sheet 3-3.
6. Reduce the input to the multicoupler in convenient steps, keeping  $A_1$  and  $A_2$  equal, and repeat steps 4 and 5. Continue to reduce the input until the third-order IM products decrease to the noise floor (see [Figure 3-6](#)).

### 3.3.6 Data Reduction

1. Plot the magnitude of the fundamental and third-order IM products versus the input power. Plot both quantities in dBm on linear paper. Extend the lines of each plot as illustrated in [Figure 3-7](#) until they intersect; this is the IP.

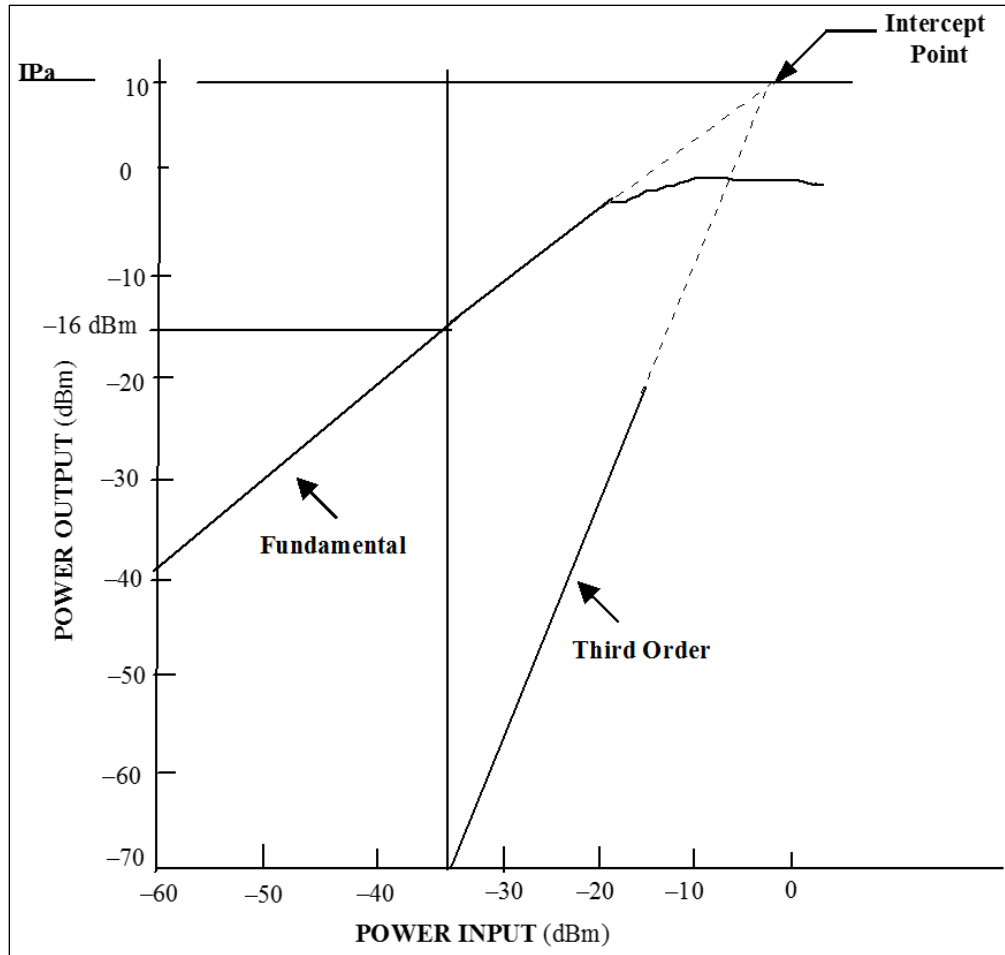



Figure 3-7. Graphical Illustration of Intercept Point

<p><b>NOTE</b></p> 	<p>Multicouplers with passbands greater than one octave may have second-order IM terms present that should be recorded and plotted (see <a href="#">Appendix A</a>).</p>
--	--

2. When the multicoupler third-order output IP ( $IP_0$ ) has been experimentally determined, the small-signal performance of a given multicoupler, having two equal amplitude signals present in the passband simultaneously, is resolved from a graphical representation as illustrated in [Figure 3-7](#).
  - a. As an example, the graphical solution in [Figure 3-7](#) shows that the third-order output IP is +10 dBm. Find the third-order IM product for an output signal level of -16 dBm. Draw a vertical line through the -16 dBm point on the fundamental IM line and extend this line until it intersects the third-order IM line. Read -70 dBm on the third-order output scale.
  - b. When only the IP is known, determine the third-order IM products for any fundamental signal output from the following equation:

Power output of the third-order products =  $3 (IP_0 - \text{fundamental output power})$  dB below IP. Using the numbers from data reduction step 2.a and [Figure 3-7](#), calculate

$$\begin{aligned} \text{Third-Order Output} &= 3[(10) - (-16)]\text{dB} && \text{(Eq. 3-3)} \\ &= 78 \text{ dB below } IP_0 \end{aligned}$$

$$\text{Third-Order Output} = -68 \text{ dBm.}$$

3. A spurious response nomograph (see [Figure 3-8](#)) can be used rather than the graphical representation to determine the small-signal performance of a given multicoupler when the output IP is known or determined experimentally from data reduction step 1.

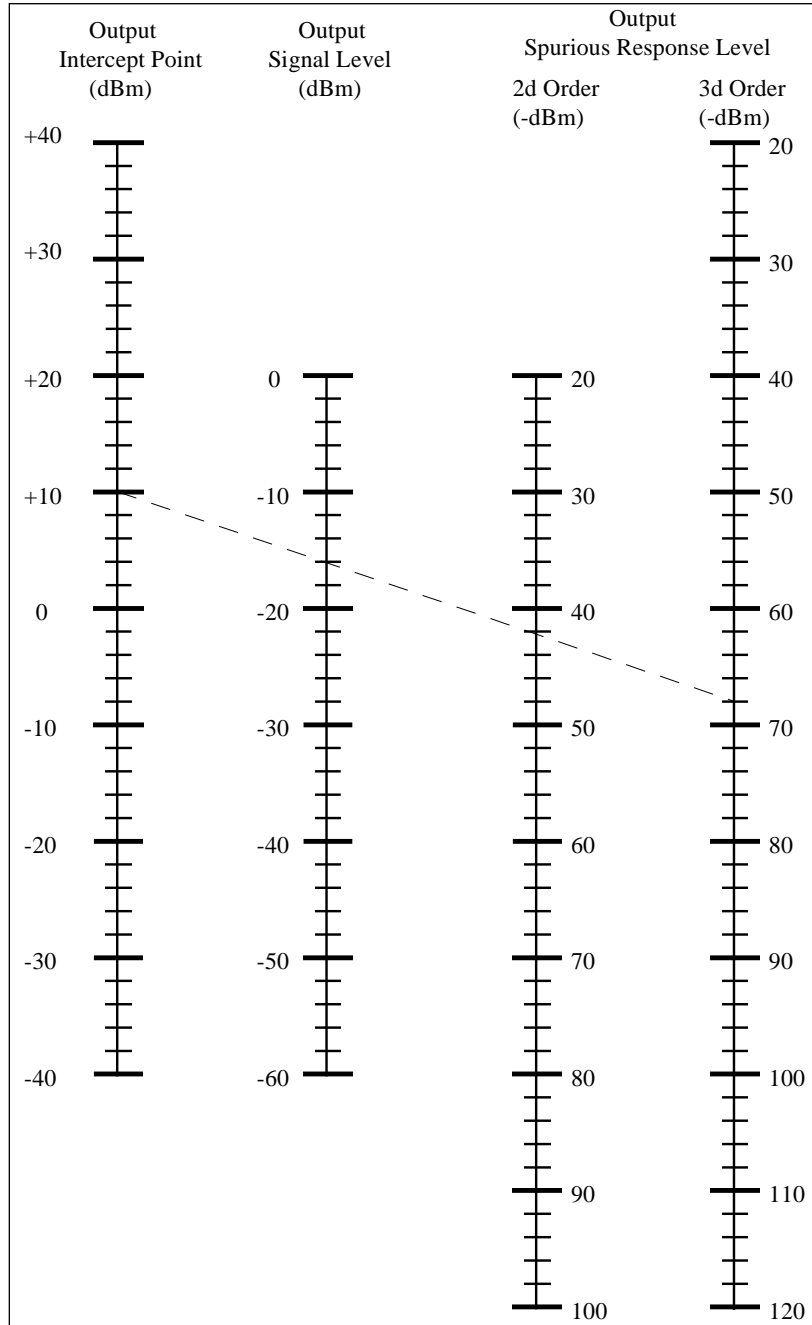

Figure 3-8. Spurious Response Nomograph

- a. Place a straight edge on the +10 dBm output and at -16 dBm on the fundamental output point.
- b. Read -68 dBm on the third-order spurious response line.





### 3.4. TEST: Multicoupler VSWR by Return Loss Method

3.4.1 Purpose. This test determines the quality of the impedance match of the device under test by measuring the VSWR using the return loss method. The VSWR allows estimation of the amount of power transferred through or reflected from a device connection as:

$$POWER\ TRANSFERRED\ (\%) = 100 (1 - \rho^2)$$

Where:  $\rho$  is the voltage reflection coefficient.

See data reduction step 2 for calculation of  $\rho$  from return loss.

3.4.2 Test Equipment. Use a network analyzer with calibration kit. Alternately, use a signal generator, 20-dB directional coupler, spectrum analyzer, termination (characteristic impedance), and RF short.

3.4.3 Setup. Connect the test equipment as shown in [Figure 3-9](#) or [Figure 3-10](#).

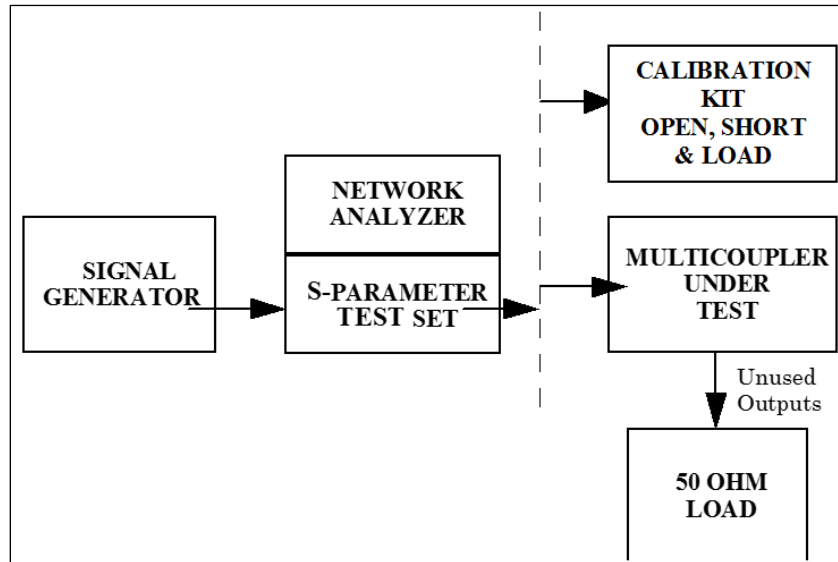

Figure 3-9. Test Setup for Measurement of Return Loss (VSWR)

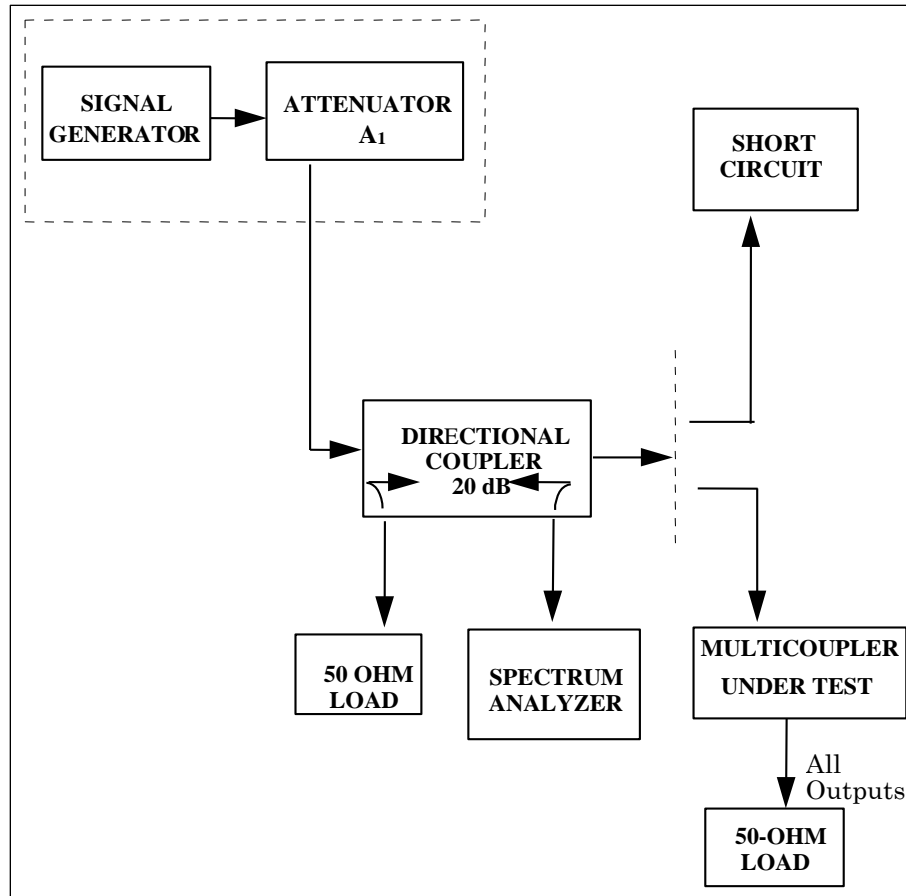



Figure 3-10. Alternate Test Setup for Measurement of Return Loss (VSWR)

3.4.4 **Conditions.** Perform this test under laboratory conditions after a warm-up time of at least 30 minutes. All procedures are conducted with continuous wave signals (unmodulated) into the device under test. Variations in operating temperature will be evaluated.

<p><b>NOTE</b></p> 	<p>The input level should be 10 dB less than the 1-dB compression point obtained in Test <a href="#">3.1</a>.</p>
--	---

3.4.5 **Procedure.** Use steps 1 to 6 for the setup in [Figure 3-9](#). Use steps 7 to 12 for the setup in [Figure 3-10](#).

1. Set up the network analyzer impedance, frequency range, number of points, and power level to the requirements of the multicoupler to be tested.
2. Calibrate the network analyzer for a  $S_{11}$  one-port test. Use the appropriate calibration kit to minimize use of coaxial adapters.
3. Set up the network analyzer display for either return loss (LOG MAG  $S_{11}$ ) or VSWR. Set the display for the desired scale range. Verify calibration accuracy by observing calibration load data on the display. Remove the calibration load and connect the multicoupler input to the directional coupler. Terminate the multicoupler output ports with its specified impedance load. Observe the measurement level on the analyzer.

 <b>NOTE</b>	Since the VSWR is a measure of the mismatch between the load and the line, it is possible to measure the voltage reflected from a load to a transmission line with a directional coupler. If the load is replaced by a short circuit whose reflection coefficient is unity, the reflected voltage measured through the directional coupler will be increased. (A short circuit reflects all the incident power.) The return loss is defined as the ratio of the voltage reflected from the short circuit to the voltage reflected from the load while keeping the input signal constant.
---	--

4. Move the network analyzer markers across the band pass of the multicoupler under test. Record the return loss in dB or VSWR at convenient increments across the band on Data Sheet 3-4. Note and record any abnormal changes in data versus frequency as the marker is moved.
5. Reverse the multicoupler connection in the test setup and repeat steps 3 and 4 to obtain the multicoupler output return loss or VSWR for each output.
6. Repeat steps 3 through 5 at high and low operating temperatures.

### **Alternate Procedure**

7. Set the generator frequency to the mid-band frequency of the multicoupler to be tested and adjust the calibrated attenuator for a level of about  $-40$  dBm into the directional coupler.

 <b>NOTE</b>	The input level should be 10 dB less than the 1-dB compression point obtained in Test <a href="#">3.1</a> .
--	---

8. Connect the short circuit termination to the coupler and establish a convenient reference level on the spectrum analyzer. A 0-dB reference is very convenient to use with the spectrum analyzer set for a log display.
9. Remove the short circuit termination and connect the multicoupler input to the directional coupler. Terminate the multicoupler output ports with its specified impedance load. Observe the signal level on the spectrum analyzer. The difference between the reference level established in step 8 and the new level observed in dB is the return loss.
10. Tune the signal generator across the band pass of the multicoupler under test. Record the return loss in dB at convenient increments across the band on Data Sheet 3-4. Note and record any abnormal changes in return loss versus frequency as the generator is tuned.
11. Reverse the multicoupler connection in the test setup and repeat steps 8 through 10 to obtain the multicoupler output return loss for each output.
12. Repeat steps 8 through 11 at high and low operating temperatures.

Data Sheet 3-4. Telemetry Multicouplers												
<b>Test 3.4</b>			<b>VSWR by return loss method including temperature variations</b>									
<b>Amplifier Manufacturer:</b>						<b>Model:</b>						
<b>Serial No.:</b>												
<b>Test Personnel:</b>						<b>Date:</b>						
Frequency (MHz)	Input Return Loss (dB)			Input VSWR <u><a href="#">Table 3-2</a></u> or Calculation			Output Return Loss (dB)			Output VSWR <u><a href="#">Table 3-2</a></u> or Calculation		
	Test 3.4	Test 3.4		Test 3.4	Test 3.4		Test 3.4	Test 3.4		Test 3.4	Test 3.4	
		Temp			Temp			Temp			Temp	
		H	L		H	L		H	L		H	L

### 3.4.6 Data Reduction

1. Convert the return loss data to equivalent VSWR by using the dB-to-VSWR values shown in [Table 3-2](#).

<b>Table 3-2. Return Loss to Equivalent VSWR</b>							
<b>dB</b>	<b>VSWR</b>	<b>dB</b>	<b>VSWR</b>	<b>dB</b>	<b>VSWR</b>	<b>dB</b>	<b>VSWR</b>
0	∞	8	2.32	17	1.33	26	1.11
.5	34.78	9	2.10	18	1.29	27	1.09
1	17.39	10	1.92	19	1.25	28	1.08
2	8.72	11	1.78	20	1.22	29	1.07
3	5.85	12	1.67	21	1.20	31	1.06
4	4.42	13	1.58	22	1.17	32	1.05
5	3.57	14	1.50	23	1.15	34	1.04
6	3.01	15	1.43	24	1.13	37	1.03
7	2.61	16	1.38	25	1.12	40	1.02

2. The VSWR can be calculated from the return loss, measured in dB, using the equations:

$$L_R = 20 \log \frac{1}{\rho} . \tag{Eq. 3-4}$$

Therefore:  $\rho = \frac{1}{\text{anti log } (L_R / 20)}$  (Eq. 3-5)

Then:  $VSWR = \frac{1 + \rho}{1 - \rho}$  (Eq. 3-6)

Where:

$L_R$  = return loss measured

$\rho$  = reflection coefficient of load being measured

## 3.5. TEST: Noise Figure

**3.5.1 Purpose.** This test measures the noise figure, which is the ratio of the input, signal-to-noise ratio (SNR) divided by the output SNR expressed in dB. Alternately, the average noise figure is the ratio of the total noise power delivered to the load when the input is at 290 K at all frequencies to that portion of noise power generated by the input termination, expressed in dB (reference IEEE Dictionary Standard 100-1988). The noise figure of the multicoupler is important because it is one factor in determining the sensitivity of the receiving system. System sensitivity establishes the lower limit of system dynamic range or range of linear operation. See [Appendix B](#) for a discussion of noise figure.

**3.5.2 Test Equipment.** Noise figure meter or noise figure system, noise source, dc block, 10-dB attenuator, receiver, and terminations (characteristic impedance).

**3.5.3 Setup.** Connect the test equipment as shown in [Figure 3-11](#) or [Figure 3-12](#).

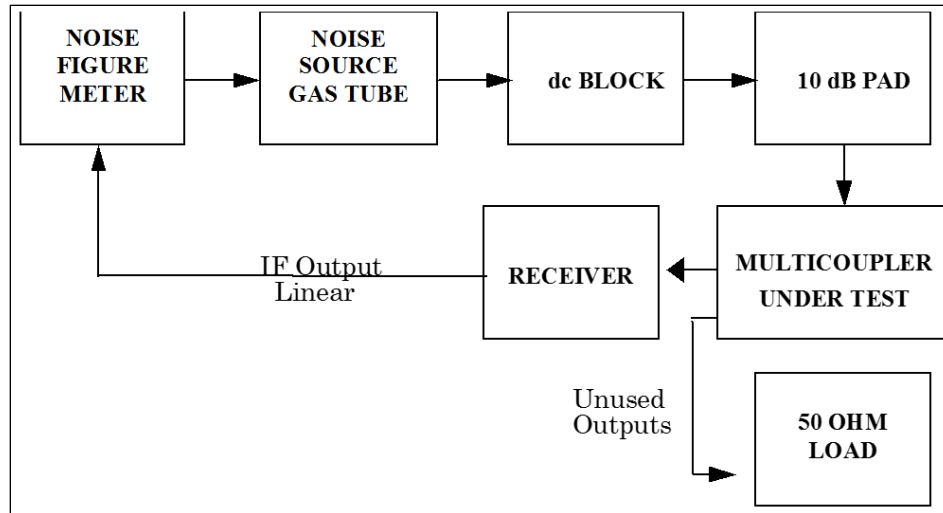

Figure 3-11. Test Setup for Measurement of Noise Figure



**Figure 3-11:** Do not remove the dc block or the 10-dB pad between the noise source and the multicoupler under test because the multicoupler may be damaged.

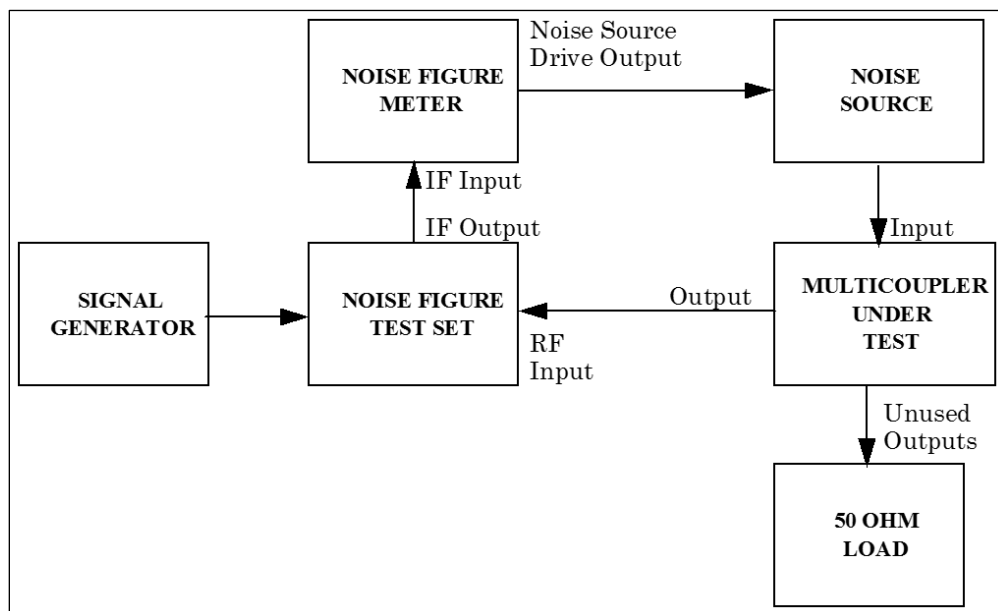



Figure 3-12. Alternate Test Setup for Measurement of Noise Figure

3.5.4 **Conditions.** Perform this test under laboratory conditions after a warm-up time of at least 30 minutes. Variations in supply voltage and operating temperature will be evaluated.

### 3.5.5 Procedure

1. In [Figure 3-11](#), set the receiver for a long time constant or set it in the AGC disable mode with the manual gain adjusted for linear operation. In [Figure 3-12](#), ensure the correct noise source excess noise ratio (ENR) data are stored in the noise figure meter.

2. Measure the noise figure. Refer to the operating instructions of the noise figure meter. Make this measurement by continuously tuning the receiver across the band of interest.
3. Record the noise figure reading in dB on Data Sheet 3-5.

 <b>NOTE</b>	If the device under test is to be used in varying atmospheric conditions, it will be necessary to initially evaluate the device under those conditions. Place the device in a chamber where climatic conditions can be controlled and varied, and repeat some or all of the previous tests.
---	---



Data Sheet 3-5.      Telemetry Multicouplers	
<b>Test 3.5</b>	<b>Noise figure</b>
<b>Amplifier Manufacturer:</b>	<b>Model:</b>
<b>Serial No.:</b>	
<b>Test Personnel:</b>	<b>Date:</b>
Frequency (MHz)	Noise Figure (dB)

### 3.6. TEST: Output Isolation

3.6.1 Purpose. This test measures the output isolation of a multicoupler, which is the isolation in dB between any two output ports with all other ports terminated in their characteristic impedance. Adequate isolation between sources can be critical to proper system operation.

3.6.2 Test Equipment. Signal generator, spectrum analyzer, and terminations (characteristic impedance).

3.6.3 Setup. Connect the test equipment as shown in [Figure 3-13](#).

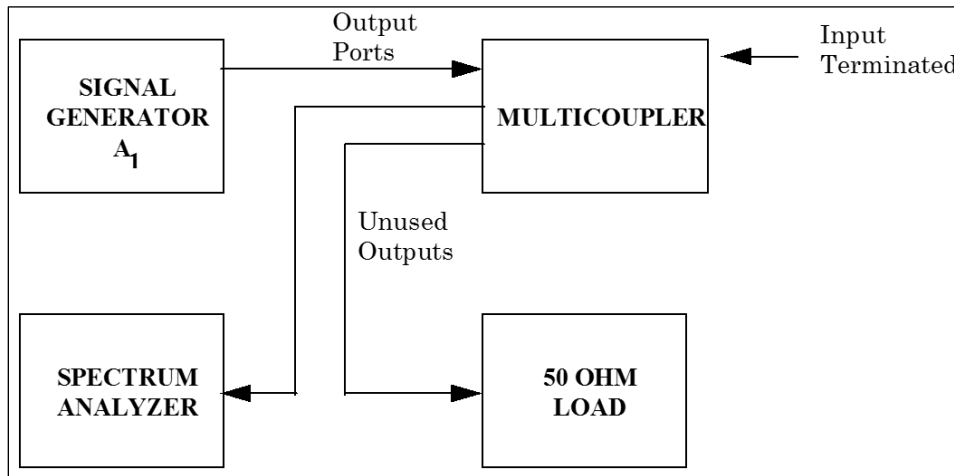

Figure 3-13. Output Isolation

3.6.4 Conditions. Perform this test under laboratory conditions after a warm-up time of at least 30 minutes. Variations in supply voltage and operating temperature may be evaluated depending on intended application.

#### 3.6.5 Procedure

1. Remove the multicoupler under test from the setup shown in [Figure 3-13](#). Set the signal generator frequency to the center of the passband and set the generator attenuator A<sub>1</sub> to a value at least 70 dB below the maximum signal generator output. Set a convenient reference level on the spectrum analyzer.
2. Record in dB the attenuator reading A<sub>1</sub> on Data Sheet 3-6.
3. Connect the multicoupler between the signal generator and the spectrum analyzer illustrated in [Figure 3-13](#) with the characteristic impedance of all unused ports terminated. Increase the signal generator attenuator A<sub>1</sub>' to return the signal level on the analyzer to reference level and record the attenuator setting A<sub>1</sub>' on Data Sheet 3-6.
4. Repeat step 3 for various frequencies in the multicoupler passband and for other pairs of output ports as required. Be aware of the amount of isolation used. It will not be possible to return the signal to the reference level if the unit has too much isolation.

3.6.6 Data Reduction. Calculate the output isolation (A<sub>1</sub>' - A<sub>1</sub>) and record on Data Sheet 3-6.



This page intentionally left blank.

## CHAPTER 4

### Test Procedures for Telemetry Receivers

#### 4. General

This chapter provides a set of test procedures to determine the performance characteristics of a TM receiver. It may not be necessary to conduct all of the tests described in this chapter for any one receiver if the receiver will be used for a specific application. Some tests are appropriate for frequency division multiplexing while others are appropriate for time division multiplexing. For example, if a system is intended to handle a large number of modulated sub-carriers, the noise power ratio (NPR) test (notch noise test) is a very practical indicator of the suitability of the receiver. On the other hand, if the system will be handling pulse code modulation (PCM) formats, the BER test is a good test. When performing the tests identified in this chapter, use the standard test conditions identified in [Table 4-1](#) unless otherwise specified.

 <p><b>NOTE</b></p>	<p>The tests in this section have been identified as Core or Non-Core tests. The Core tests are the ones that should always be conducted by ranges on their TM receivers whenever possible. Non-Core tests are still important but may be deemed optional based on the specific needs of individual ranges.</p>
--	---

<b>Table 4-1. Standard Test Conditions</b>	
Minimum warm-up time:	30 minutes
Input signal frequency:	Mid-band
RF input level:	As stated in procedure
First local oscillator:	Desired operational mode
IF bandwidth:	Desired operational bandwidth
Demodulator type:	FM
AFC:	Off
AGC:	On, shortest time constant
Video bandwidth:	Maximum available
Video output:	1 V rms
Video amplifier:	Terminate in design load impedance

[Table 4-2](#) lists the types of tests and their test and paragraph number.

<b>Table 4-2. Test Matrix for TM Receivers</b>	
<b>Test Number</b>	<b>Test Description</b>
<a href="#">4.1</a>	Spurious signal response test (CORE)
<a href="#">4.2</a>	Noise figure (CORE)
<a href="#">4.3</a>	IF SNR Linearity Test (CORE)
<a href="#">4.4</a>	AGC static test (CORE)
<a href="#">4.5</a>	AGC dynamic test – Response to square wave (NON-CORE)
<a href="#">4.6</a>	AGC dynamic test – Response to sine wave test (NON-CORE)
<a href="#">4.7</a>	FM capture ratio (NON-CORE)

**Table 4-2. Test Matrix for TM Receivers**

Test Number	Test Description
<a href="#">4.8</a>	NPR (NON-CORE)
<a href="#">4.9</a>	Local oscillator radiation (CORE)
<a href="#">4.10</a>	Local oscillator stability (NON-CORE)
<a href="#">4.11</a>	PCM BER (NON-CORE) See Subsection <a href="#">7.1</a> for updated BER testing.
<a href="#">4.12</a>	Frequency modulation step response (NON-CORE)
<a href="#">4.13</a>	Receiver band pass frequency response using unmodulated signal (CORE)
<a href="#">4.14</a>	Receiver band pass frequency response using phase-modulated signal (CORE)
<a href="#">4.15</a>	Receiver band pass frequency response using white-noise input (CORE)
<a href="#">4.16</a>	Data frequency response (NONE-CORE)
<a href="#">4.17</a>	AGC stability (NON-CORE)
<a href="#">4.18</a>	Receiver video spurious outputs (NON-CORE)
<a href="#">4.19</a>	Pre-detection carrier output (NON-CORE)
<a href="#">4.20</a>	FM receiver dc linearity and deviation sensitivity (NON-CORE)
<a href="#">4.21</a>	Receiver phase noise (CORE)
<a href="#">4.22</a>	Receiver adjacent-channel interference (CORE)

#### 4.1. TEST: Spurious Signal Response

4.1.1 **Purpose.** This test determines how a TM receiver reacts to the presence of a strong RF signal that is outside of the passband to which the receiver is tuned. This situation can occur frequently on a major test range or other location where multiple RF TM signals are being transmitted at the same time from multiple test vehicles at varying distances from the TM receive site.

4.1.2 **Test Equipment.** An RF frequency synthesizer or RF generator, microwave counter, step attenuator (0 to 60-dB minimum), 3-way power splitter, spectrum analyzers, and dc voltmeter.

4.1.3 **Test Method.** This test measures spurious response by applying a large out-of-passband signal to the receiver input. The resulting AGC voltage is compared with the AGC voltage produced when a smaller (typically -60 dB) signal is applied with a frequency equal to the receiver center frequency. The spectra at the receiver input and IF output are also monitored.

4.1.4 **Setup.** Connect the test equipment as shown in [Figure 4-1](#).

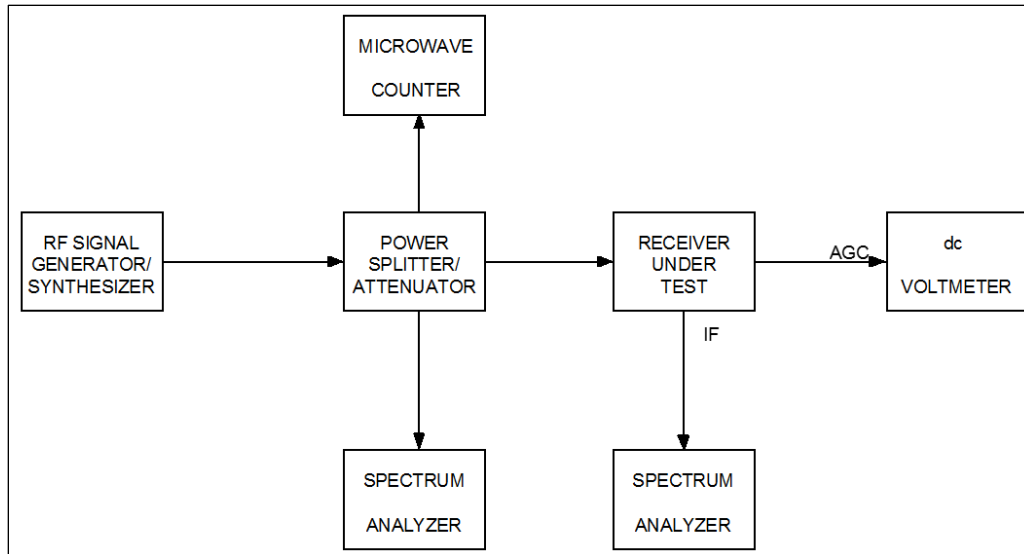

Figure 4-1. Receiver Spurious Signal Response Test

4.1.5 **Conditions.** Set the RF generator to continuous-wave mode. Any spurious signals at the RF generator output should be at least 10 dB below the specified value of receiver spurious rejection. The receiver local oscillators should be set to crystal mode, if possible. Set the receiver IF bandwidth to 1 MHz (or the closest value to 1 MHz). Set the frequency spans of the spectrum analyzers to approximately four times the receiver IF bandwidth and the resolution bandwidths (RBWs) to 10 kHz.

#### 4.1.6 Procedure

1. Set the receiver tuner to the center of its tuning range. Set the RF generator to the receiver center frequency with a signal level of  $-30$  dBm. Set the step attenuator to the specified value of spurious rejection (60 dB is a typical value, 60-dB attenuation would result in a signal level of  $-90$  dBm). Measure the receiver AGC voltage and record on Data Sheet 4-1.
2. Set the RF generator frequency to a value at least 10 MHz below the lowest tuner frequency. Decrease the step attenuation to 0 dB. Slowly increase the RF generator frequency while monitoring the dc voltmeter and spectrum analyzers. If the AGC voltage indicates a signal that is stronger than that measured in step 1, record the maximum AGC voltage and the RF generator frequency on Data Sheet 4-1 after verifying that the RF generator does not have a spurious component at the receiver center frequency. Continue increasing the RF generator frequency until it is at least 10 MHz higher than the highest tuner frequency. Monitor the IF SNR on the spectrum analyzer throughout this test. Note any degradation in IF SNR.

#### NOTE



The AGC voltage should indicate a strong signal when the RF generator is at the receiver center frequency. Do not record values on the Data Sheet when the RF generator frequency is within the  $-60$  dB band pass of the receiver.

3. Repeat steps 1 and 2 for other receiver center frequencies as desired.
4. Turn the RF generator off. Monitor the spectrum of the receiver IF output while tuning the receiver from its lowest frequency to its highest frequency. If any discrete signals appear on the spectrum display, record the tuner frequency and AGC voltage on Data Sheet 4-1. For

this test, discrete signals are defined as signals that are more than 6 dB above the background noise level.

5. This test can be automated if the RF generator, spectrum analyzer, receiver, frequency counter, step attenuator, and dc voltmeter are under computer control. The RF generator step size should be equal to or less than the receiver IF bandwidth.



<b>Data Sheet 4-1. Telemetry Receivers</b>	
<b>Test 4.1</b>	<b>Spurious signal response</b>
<b>Receiver Manufacturer:</b>	<b>Model:</b>
<b>Serial No:</b>	
<b>Test personnel:</b>	<b>Date:</b>
Center frequency: _____ (MHz)	IF BW _____ (kHz)
Final LO mode: _____ XTAL _____ Variable Frequency Oscillator (VFO)	
Location: _____	
Receiver AGC voltage (60-dB attenuation): _____ volts	
<u>RF generator frequency</u> _____ _____ _____ _____	<u>AGC voltage</u> _____ _____ _____ _____
<u>Receiver tuner frequency</u> _____ _____ _____ _____	<u>Amplitude of discrete signal</u> _____ _____ _____ _____
*BW - bandwidth	

## 4.2. TEST: Noise Figure

4.2.1 Purpose. This test measures the noise figure that is the ratio of the input signal to noise divided by the output signal to noise expressed in dB. See [Appendix B](#) for a discussion of noise figure. The noise figure of a device is a measure of how much noise is added to the signal by that device. The lower the noise figure, the better the device.

4.2.2 Test Equipment. Noise source and noise figure meter.

4.2.3 Setup. Connect the test equipment as shown in the manual for the noise figure meter.

4.2.4 Conditions. Use the test conditions described in the manual for the noise figure meter. Use the standard test conditions described in [Table 4-1](#) if not covered in the noise figure meter manual.

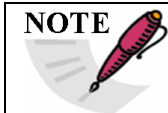

**NOTE** If the AGC time constants will not permit measurement of noise figure in the automatic mode, switch the receiver to MGC and adjust the gain as recommended by the manufacturer. If MGC is not available, this test should be eliminated. Also, make certain the gain of the receiver under test is linear.

### 4.2.5 Procedure

1. Tune the receiver slowly across the entire range with the noise figure meter operating in the automatic mode and properly adjusted. Note the maximum and minimum readings as well as any abrupt changes in noise figure. After verifying the calibration of the instrument at these settings, record the noise figures and the corresponding readings of the tuning dial on Data Sheet 4-2 for the minimum and maximum values.
2. Conduct noise figure measurement in 10-MHz increments across the entire tuning range of the receiver.

4.2.6 Data Reduction. Plot measured data as shown in [Figure 4-2](#).

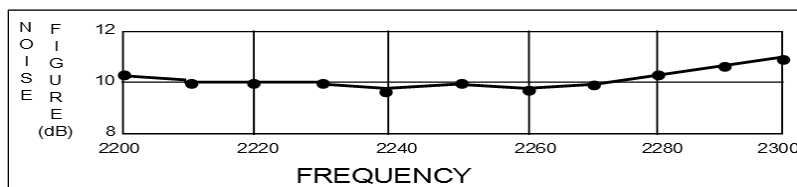



Figure 4-2. Noise Figure Plot

<b>Data Sheet 4-2. Telemetry Receivers</b>	
<b>Test 4.2</b>	<b>Noise figure</b>
<b>Manufacturer:</b>	<b>Model:</b>
<b>Serial No:</b>	
<b>Test personnel:</b>	<b>Date:</b>
Receiver Tuning (MHz)	Noise Figure (dB)
Freq =	Max NF =
Freq =	Min NF =
<b>Note:</b> Take additional readings where data slope changes abruptly.	

### 4.3. TEST: IF SNR Linearity Test

4.3.1 Purpose. This test determines the linearity of the receiver linear IF output. This test will determine how well the linear IF SNR tracks the RF input signal power. It is important for proper operation with diversity combiners or other devices that depend on the linearity of the receiver IF for correct operation.

 <b>NOTE</b>	Many receivers have a limited IF output as well. Be sure not to use this output for this test.
---	--

4.3.2 Test Equipment. Signal generator and true rms voltmeter.

4.3.3 Setup. Connect the test equipment as shown in [Figure 4-1](#).

4.3.4 Conditions. Use the standard test conditions described in [Table 4-1](#).

4.3.5 Procedure

1. Use the true rms voltmeter to measure the linear output of the final IF with  $-10$ -dBm RF input power applied to the receiver input (unmodulated) and the AGC on. The IF output should be loaded with the impedance recommended by the manufacturer. This measurement of signal plus noise is identified as  $V_1$ .
2. Set the receiver controls for MGC. Adjust the MGC to produce a linear final IF output having the same amplitude ( $V_1$ ) as that measured with  $-10$  dBm applied to the input with the AGC on.
3. Remove the RF signal from the receiver input and terminate the input at 50 ohms. Again measure the linear output of the second IF with the true rms voltmeter. This measurement of noise voltage is identified as  $V_2$ .
4. Record the measured data on Data Sheet 4-3.
5. Repeat steps 1 through 4 in 10-dB increments from  $-10$  to  $-120$  dBm.

4.3.6 Data Reduction

1. Calculate the voltage  $SNR$  out of the final IF from the following equation:

$$SNR = \sqrt{(V_1/V_2)^2 - 1} \quad (\text{Eq. 4-1})$$

This is a numerical ratio and may be changed to dB as follows:

$$SNR (dB) = 20 \log SNR \quad (\text{Eq. 4-2})$$

2. Calculate SNR for each of the RF input power levels shown on Data Sheet 4-3.

<b>Data Sheet 4-3. Telemetry Receivers</b>				
<b>Test 4.3</b>		<b>IF SNR</b>		
<b>Manufacturer:</b>		<b>Model:</b>		
<b>Serial No:</b>				
<b>Test personnel:</b>		<b>Date:</b>		
<b>RF Input Power</b> (dBm)	<b>Second IF Output</b> (Measured Values)		<b>SNR</b> (Calculated Values)	
	Signal + Noise $V_1$ (mV rms)	Noise $V_2$ (mV rms)	SNR	SNR (dB)
-10				
-20				
-30				
-40				
-50				
-60				
-70				
-80				
-90				
-100				
-110				
-120				
NO SIGNAL				
<b>Note:</b> Take additional readings where data slope changes abruptly.				

#### 4.4. TEST: AGC Static

4.4.1 Purpose. This test determines the AGC output characteristic as a function of the RF input level to the receiver and determines its effectiveness in controlling the linear IF signal amplitude.

4.4.2 Test Equipment. Signal generator, power meter, digital voltmeter, and true rms voltmeter.

4.4.3 Setup. Connect the test equipment as shown in [Figure 4-3](#).

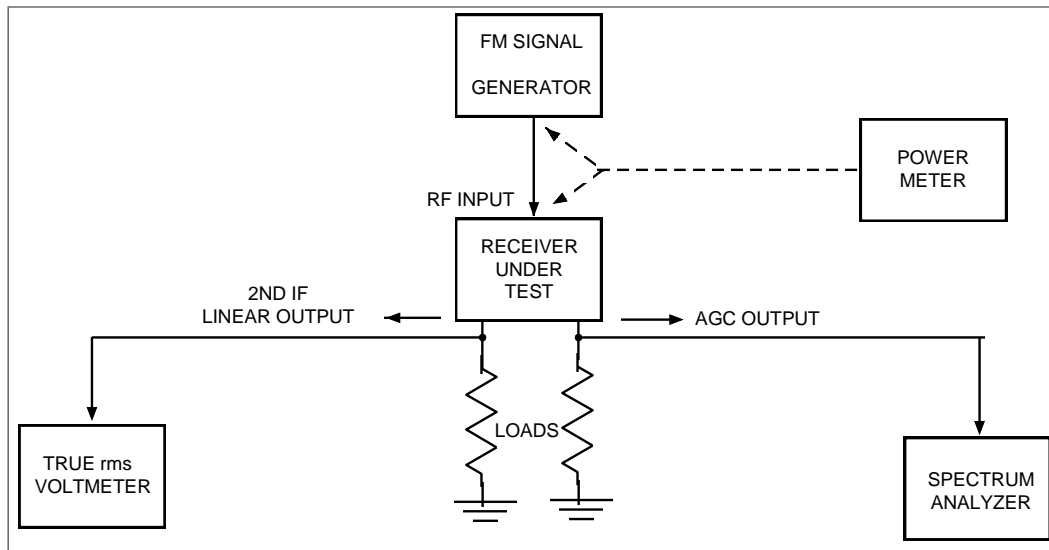

Figure 4-3. AGC Static Test

4.4.4 Conditions. Use the standard test conditions described in [Table 4-1](#) except as follows:

Input amplitude: as stated in the test procedure  
AGC: ON, maximum time constant

#### 4.4.5 Procedure

1. Use the power meter to measure the insertion loss of the cable that connects the FM signal generator to the receiver under test. Use this measured insertion loss to compensate the RF power setting of the FM signal generator in the following steps.
2. Adjust the FM signal generator output for a receiver mid-band frequency and a  $-10$ -dBm input to the receiver.
3. Tune the receiver for proper reception of the input signal (0 on tuning meter).
4. Measure and record the AGC output level with the digital voltmeter.
5. Measure and record the IF output amplitude with the true rms voltmeter.
6. Record measured data on Data Sheet 4-4.
7. Measure and record the AGC voltages and the IF output amplitude in 10-dB increments from  $-10$  to  $-120$  dBm.

4.4.6 Data Reduction. Plot the AGC and the IF characteristics as illustrated in [Figure 4-4](#).

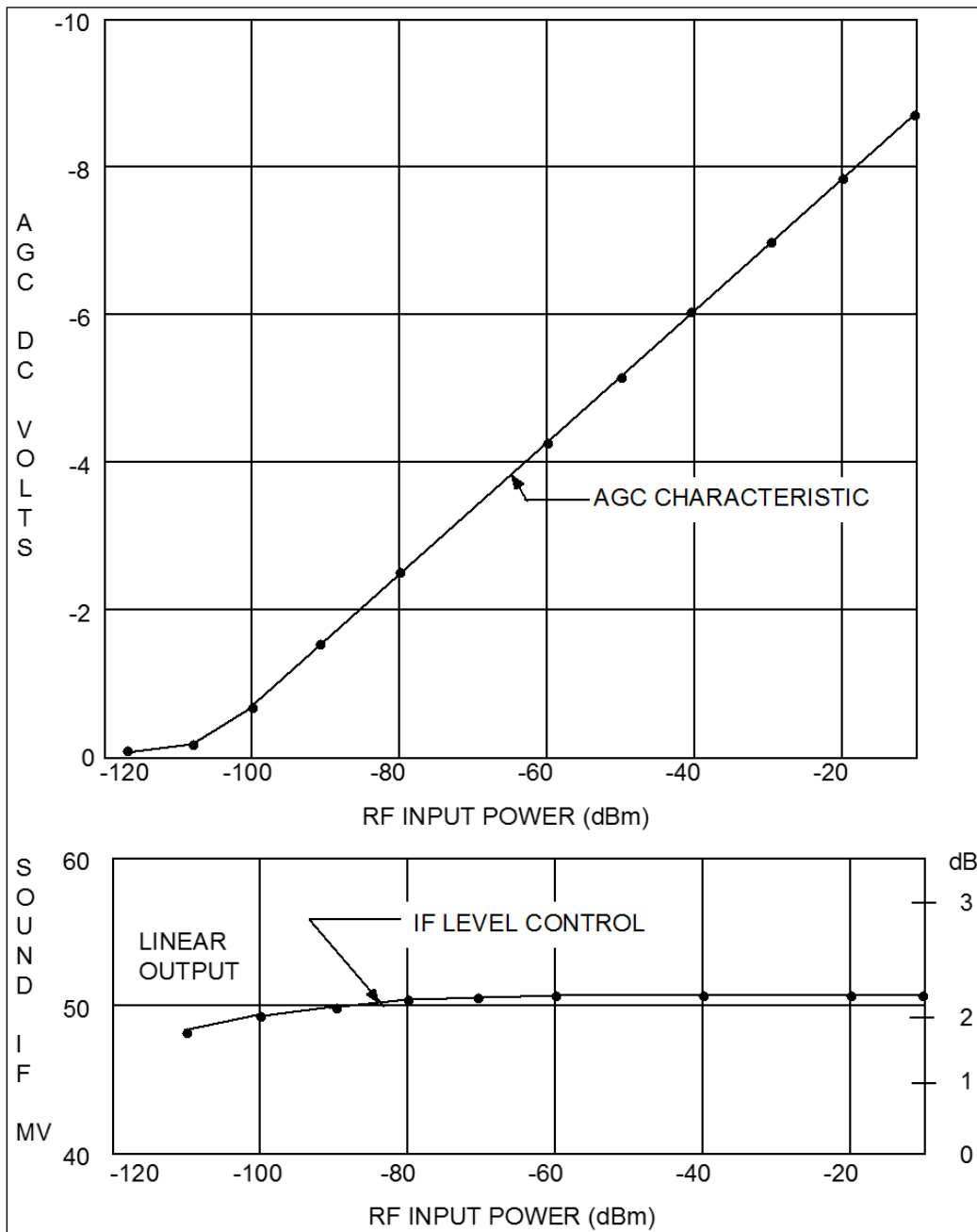

Figure 4-4. AGC Characteristics and IF Level Control

<b>Data Sheet 4-4      Telemetry Receivers</b>		
<b>Test 4.4</b>		<b>AGC static</b>
<b>Manufacturer:</b>		<b>Model:</b>
<b>Serial No:</b>		
<b>Test Personnel:</b>		<b>Date:</b>
Cable loss (FM signal generator to receiver)		dB
Receiver RF Input Power (dBm)	AGC Output Level (Vdc)	IF Output Amplitude (mV rms)
-10		
-20		
-30		
-40		
-50		
-60		
-70		
-80		
-90		
-100		
-110		
-120		
NO SIGNAL		
<b>Note:</b> Take additional readings where data slope changes abruptly.		



#### 4.5. TEST: AGC Dynamic Test - Response to Square Wave

4.5.1 **Purpose.** This test determines the AGC attack and recovery time with square wave AM. In addition, it shows the effects of abrupt changes in the RF power level on AGC voltages, IF signals and video output.

4.5.2 **Test Equipment.** Function generator, signal generator with AM modulation capability or a separate PIN modulator, power meter, oscilloscope and camera, digital voltmeter, and true rms voltmeter.

4.5.3 **Setup.** Connect the test equipment as shown in [Figure 4-5](#) and set the oscilloscope channel 1 and 2 input selector switches to dc.

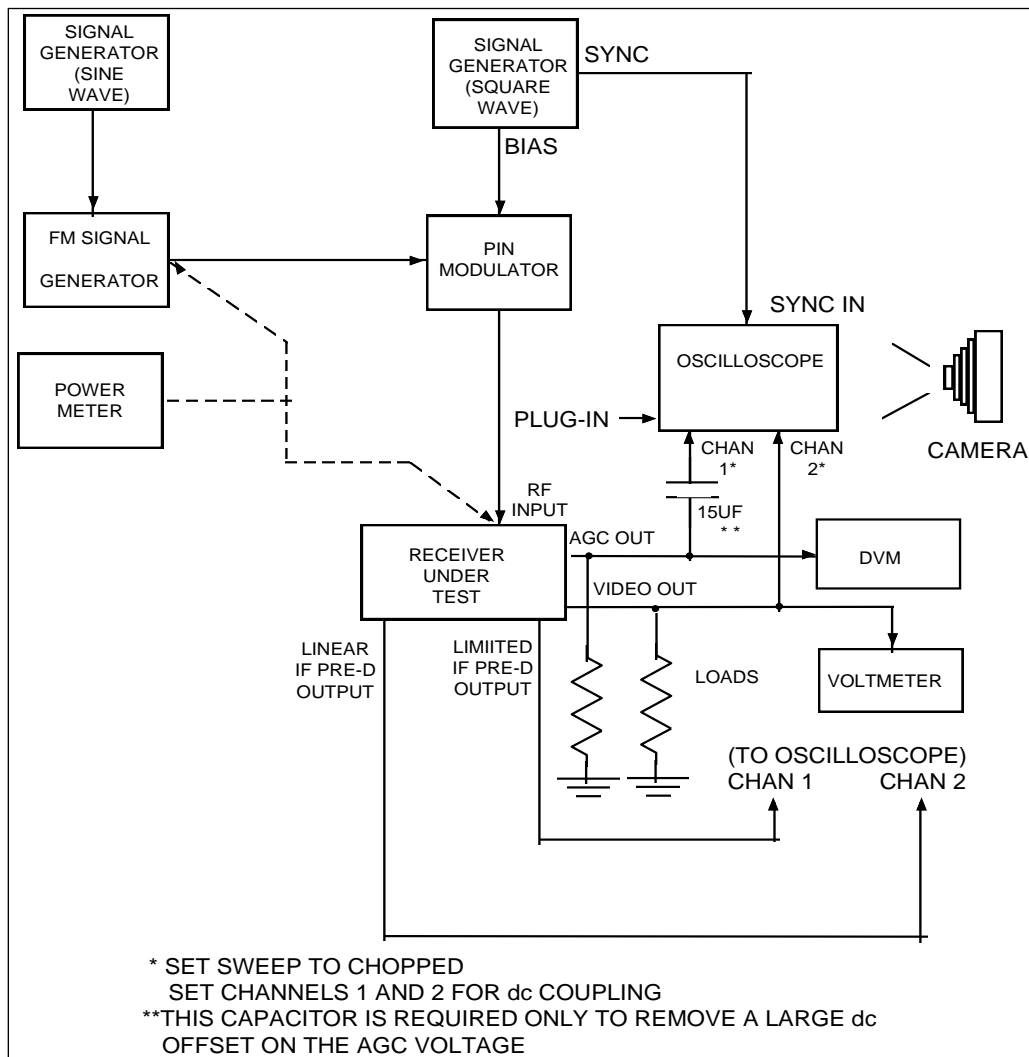

Figure 4-5. AGC Response to Square Wave AM

4.5.4 **Conditions.** Use the standard test conditions described in [Table 4-1](#) except as follows:

- RF input power: as stated in the test procedure
- AGC: as stated in the test procedure
- Modulation frequency: variable



One set of measurements is conducted with only AM applied to the carrier. An oscilloscope presentation is examined to determine both attack and recovery times of the AGC circuit. Another set of measurements is conducted with both AM and FM applied to the carrier. The oscilloscope displays are photographed to show AGC response, limited and linear IF signal response, and the video output signal.

#### 4.5.5 Procedure

1. Use the RF power meter, with no bias applied in the PIN modulator as illustrated in [Figure 4-5](#), to measure the insertion loss of cables and the PIN modulator connected between the receiver input and the FM signal generator.
2. Tune the receiver for proper reception of the input signal and adjust the receiver AGC time constant to the minimum setting.



Compensate for this insertion loss when applying RF power to the receiver input in subsequent measurements.

3. Reconnect the bias signal (square wave) to the PIN modulator to apply AM to the receiver input signal.
4. Use the calibration of the AGC output voltage versus the RF input voltage previously measured and tabulated on Data Sheet 4-5 in the Static AGC test when adjusting the desired amplitude of modulation.
5. Set the mean level of the receiver input signal by adjusting the RF output of the signal generator.
6. Select those settings of the PIN modulator bias and the signal generator output that cause the receiver input to vary between the power levels of  $-57$  and  $-97$  dBm. Temporarily adjust the frequency of the square wave bias signal to approximately 0.1 Hz. This frequency allows sufficient time to read the resulting AGC output voltage with the digital voltmeter and make appropriate adjustments.
7. Adjust the frequency of the bias signal to show the maximum excursion of the AGC characteristic with a level portion equal to approximately one-quarter of the cycle period.
8. Adjust the sweep speed of the oscilloscope for a calibrated setting that will give the maximum sweep speed but show one full cycle of the AGC characteristic.
9. Display the resulting AGC characteristic on the oscilloscope so that the trace is centered and the vertical deflection on the oscilloscope is 5 cm (1.96 in).
10. Select the polarity of the vertical amplifier so that the part of the AGC trace corresponding to the lower RF level is at the bottom of the display.
11. Inspect the oscilloscope trace to determine the attack time and recovery time. The attack time is the time required for the AGC voltage to change from 10 to 90 percent of the full range indicated on the oscilloscope as the input RF power level changes from  $-97$  to  $-57$  dBm. The

recovery time is the time required for the 10 to 90 percent change of the AGC voltage when the input changes from  $-57$  to  $-97$  dBm. Record these values on Data Sheet 4-5.

12. Adjust the modulation input to the FM signal generator to produce a 200-kHz peak deviation of the RF signal input to the receiver with the AM still applied to the carrier.
13. Ensure that the modulation frequency is approximately eight times the frequency of the bias signal applied to the PIN modulator.
14. Set the receiver AGC time constant to minimum.
15. Adjust the video gain of the receiver to produce 1 V rms output and connect the video signal channel 2 input of the oscilloscope.
16. Superimpose the video signal on the AGC trace and position the video signal in the top half of the display as illustrated on Data Sheet 4-5.
17. Ensure that the vertical deflection of the video signal is 2 cm (0.79 in).
18. Adjust the FM frequency to produce a stationary oscilloscope presentation.
19. Photograph the oscilloscope display of the AGC and video output characteristics.

 <b>NOTE</b>	The preceding measurement procedures may be repeated for other settings of the receiver AGC time constant as required.
---	--

20. Disconnect the AGC and the video output from the oscilloscope and connect the linear and limited outputs of the second IF to the oscilloscope (see [Figure 4-5](#)).
21. Position the limited IF trace at the bottom of the display and adjust the vertical amplifier gain to produce a 1-cm (0.39 in) deflection.
22. Position the linear IF trace in the center of the display and adjust the vertical amplifier gain to produce a 1-cm (0.39 in) deflection for the quiescent state.
23. Photograph the IF output signals.
24. Take additional photographs of the AGC, the video output, and the IF output signals corresponding to RF input power level changes of  $-77$  to  $-97$  dBm,  $-37$  to  $-97$  dBm,  $-37$  to  $-57$  dBm, and  $-37$  to  $-77$  dBm.

#### 4.5.6 Data Reduction

1. Attach photographs to Data Sheet 4-5 as illustrated.
2. Inspection of the photographs will yield several items of qualitative information relative to AGC characteristics. The AGC attack and recovery times are determined and compared, degradation intervals of the receiver video output resulting from the imperfect response of the AGC circuit and demodulator are observed, and the dynamic response of both the limited and linear IF signals to AGC action are shown.

**Data Sheet 4-5. Telemetry Receivers**

**Test 4.5** **AGC dynamic test - response to square wave**

**Manufacturer:** **Model:**

**Serial No:**

**Test Personnel:** **Date:**

Receiver AGC Setting	Measured AGC Attack Time (ms)	Measured AGC Recovery Time (ms)
_____	_____	_____
_____	_____	_____
_____	_____	_____
_____	_____	_____
_____	_____	_____
_____	_____	_____

AGC Attack and Recovery, Video and IF Characteristics



LINEAR  
IF  
  
LIMITED  
IF

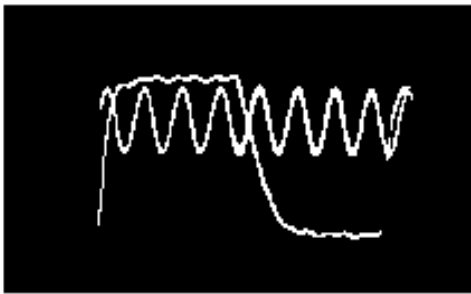

VIDEO  
  
AGC

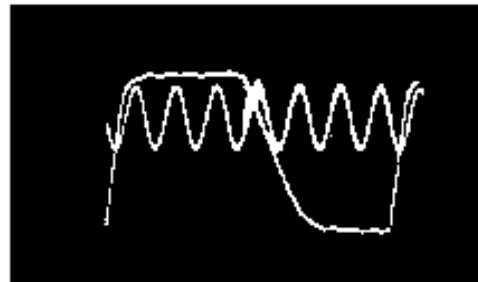

RF Input: -57 dBm to -97 dBm

RF Input: -37 dBm to -97 dBm

Sweep Speed \_\_\_\_\_ millisc/div

Sweep Speed \_\_\_\_\_ millisc/div

**Data Sheet 4-5 (continued)**

**Telemetry Receivers**

**TEST: 4.5 AGC dynamic test - Response to square wave**

Manufacturer:

Model:

Serial No:

Test personnel:

Date:



LINEAR  
IF  
  
LIMITED  
IF



VIDEO  
  
AGC

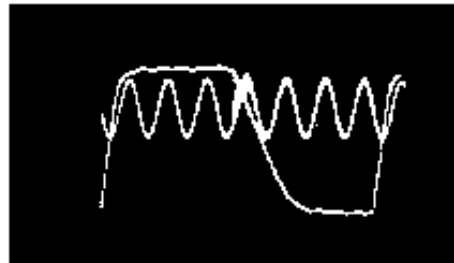

RF Input: -77 dBm to -97 dBm

Sweep Speed \_\_\_\_ millisec/div

RF Input: -37 dBm to -57 dBm

Sweep Speed \_\_\_\_ millisec/div

#### 4.6. TEST: AGC Dynamic Test - Response to Sine Wave

4.6.1 Purpose. This test determines the AGC attack and recovery time with a sine wave. It also shows the effects of changes in RF power level on AGC voltages, IF signals and video output.

4.6.2 Test Equipment. Power supply, audio signal generator, RF signal generator, PIN modulator, counter, oscilloscope, true rms voltmeter, and digital voltmeter.

4.6.3 Setup. Connect the test equipment as shown in [Figure 4-6](#) and set the oscilloscope channel 1 and 2 input selector switches to dc.

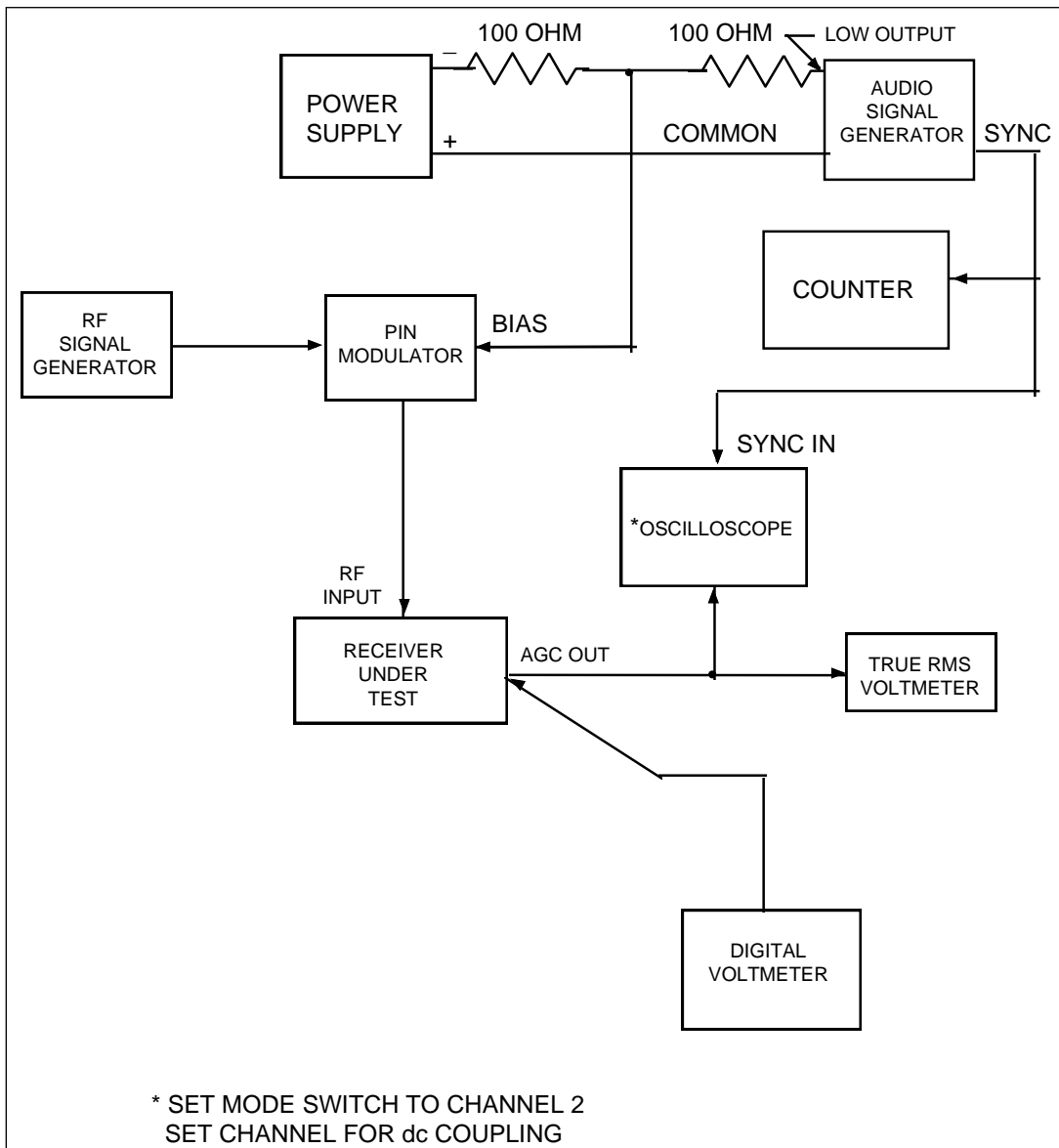

Figure 4-6. AGC Response to Sine Wave AM

4.6.4 Conditions. Use the test conditions described in Subsection [4.5.5](#) step 2.

#### 4.6.5 Procedure

1. Set the output level of the RF signal generator to  $-15$  dBm.
2. Adjust the dc bias on the PIN modulator to produce a  $-45$  dBm input to the receiver with no output from the audio signal generator as indicated by the AGC output voltage calibration plot obtained in the static AGC test.
3. Set the receiver AGC to the shortest time constant.
4. Set the frequency of the audio signal generator to a frequency determined by the formula  $f = 10/TC$ , where  $f$  is in hertz and  $TC$  (time constant) is in milliseconds. The result is the attack time corresponding to an input RF power level change from  $-77$  to  $-37$  dBm.
5. Determine from the plot of the static AGC test data the AGC voltage difference corresponding to an RF input change between  $-26$  and  $-20$  dBm.
6. Adjust the output voltage of the audio signal generator to produce an AGC signal the magnitude of this difference.

**NOTE**

At modulating frequencies below 10 Hz, the AGC signal should be measured with a direct-coupled oscilloscope. At modulating frequencies above 10 Hz, the AGC signal may be measured with a true rms voltmeter. To convert the static AGC voltage change obtained from the plot to rms, multiply by 0.35.

7. Increase the frequency of the audio signal generator and measure the frequencies at which the AGC output voltage excursion decreases by 3, 6, 9, and 12 dB ( $f_3$ ,  $f_6$ ,  $f_9$ , and  $f_{12}$  represent the frequencies at the  $-3$ ,  $-6$ ,  $-9$ , and  $-12$  dB points).
8. Record these frequency readings on Data Sheet 4-6.
9. Repeat procedure for other time constant settings of receivers as required.
10. Repeat the previous measurements of an AGC voltage difference corresponding to an RF input change between  $-70$  and  $-64$  dBm.

Data Sheet 4-6      Telemetry Receivers					
<b>Test 4.6</b>		<b>AGC dynamic test - response to sine wave</b>			
<b>Manufacturer:</b>			<b>Model:</b>		
<b>Serial No:</b>			<b>Date:</b>		
<b>Test Personnel:</b>					
<b><u>-20 dBm to -26 dBm</u></b>					
<b>Receiver AGC Setting</b>	<b>f<sub>0</sub></b>	<b>f<sub>3</sub></b>	<b>f<sub>6</sub></b>	<b>f<sub>9</sub></b>	<b>f<sub>12</sub></b>
Milliseconds	Hertz	Hertz	Hertz	Hertz	Hertz
0.1*					
1.0*					
10 *					
<b><u>-64 dBm to -70 dBm</u></b>					
<b>Receiver AGC Setting</b>	<b>f<sub>0</sub></b>	<b>f<sub>3</sub></b>	<b>f<sub>6</sub></b>	<b>f<sub>9</sub></b>	<b>f<sub>12</sub></b>
Milliseconds	Hertz	Hertz	Hertz	Hertz	Hertz
0.1*					
1.0*					
10 *					
*These settings may vary with receiver models.					



#### 4.7. TEST: FM Capture Ratio

4.7.1 Purpose. This test determines the FM capture ratio of the receiver. The capture ratio relates to the ability of the receiver to capture the stronger of two co-channel frequency modulated signals applied to the receiver input terminals. This applies to limiter discriminator for Tier 0 systems only.

4.7.2 Test Equipment. Counter, two FM signal generators, power meter, wave analyzer, two 10-dB attenuator pads, 20-dB attenuator pad, and power adder.

4.7.3 Setup. Connect the test equipment as shown in [Figure 4-7](#).

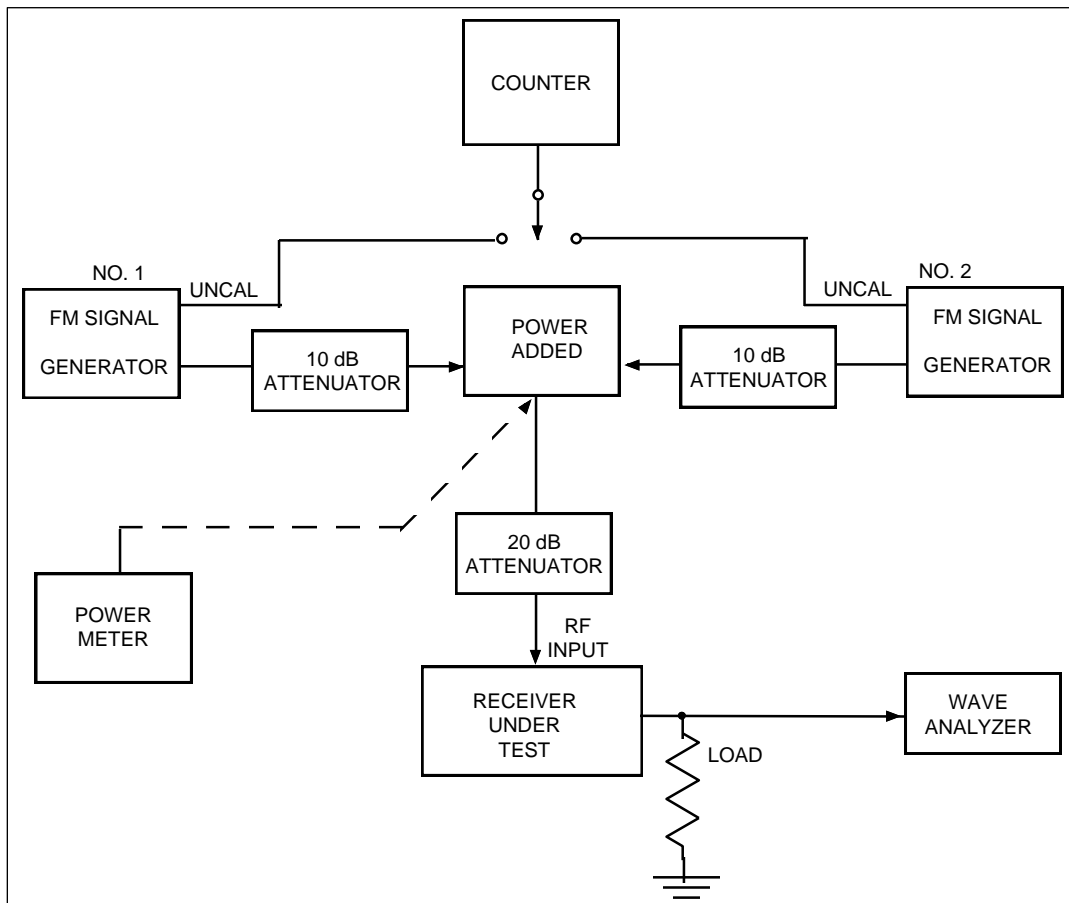



Figure 4-7. Capture Ratio Test

4.7.4 Conditions. Use the standard test conditions described in [Table 4-1](#), except as follows.

Input amplitude: variable  
AGC: 10 ms  
Video bandwidth: 100 kHz  
Carrier deviation no. 1: 200 kHz peak  
Modulation frequency: IRIG Channel 13 (14.5 kHz)  
Carrier deviation no. 2: 200 kHz peak  
Modulation frequency: IRIG Channel 16 (40 kHz)

#### 4.7.5 Procedure

1. Adjust the frequency of the number 2 signal generator for receiver mid-band and the output level for minimum output.
2. Adjust the frequency of the number 1 signal generator to within 5 kHz of generator number 2 and the output level to  $-25$  dBm as indicated by the power meter.
3. Record the attenuation reading that is on the signal generator dial. This is reference level  $P_1$ .
4. Frequency modulate the number 1 signal generator with a 14.5-kHz sine wave.
5. Adjust the deviation for a 200-kHz peak as indicated on the deviation meter.
6. Adjust the output level of the number 1 signal generator for minimum output and increase output level of signal generator number 2 to  $-25$  dBm as indicated by the power meter.
7. Frequency modulate the number 2 signal generator with a 40-kHz sine wave and adjust the deviation for a 200-kHz peak as indicated on the deviation meter.
8. Disconnect the power adder from the power meter and connect it to the receiver input through a 20-dB attenuator.
9. Tune the receiver for proper reception of the input signal (0 on tuning meter).

 <b>NOTE</b>	For all subsequent measurements, maintain the frequencies of the signal generators within 5 kHz of each other.
--	--

10. Tune the wave analyzer to the 40-kHz signal and adjust the receiver video output of 1 V rms.
11. Tune the wave analyzer to the 14.5-kHz modulation signal and increase the output of signal generator number 1 until the analyzer reads 0.1 V rms ( $-20$  dB relative to one volt [dBV]).
12. Record data on Data Sheet 4-7.

- 4.7.6 Data Reduction. Calculate the capture ratio as indicated on Data Sheet 4-7.

<b>Data Sheet 4-7.      Telemetry Receivers</b>	
<b>Test 4.7</b>	<b>FM capture ratio</b>
<b>Manufacturer:</b>	<b>Model:</b>
<b>Serial No:</b>	
<b>Test Personnel:</b>	<b>Date:</b>
<p><b>Signal generator No. 1</b></p> <p><math>P_1</math> _____ dBm</p> <p><math>P_2</math> _____ dBm</p> <p>Capture ratio = <math>P_1 - P_2 =</math> _____ dB</p>	

## 4.8. TEST: NPR

4.8.1 Purpose. This test measures the NPR and the NPR floor (NPRF) and determines the NPR intermodulation (NPRI) noise. This test only applies to FM/FM and systems using sub-carrier oscillators.

<p><b>NOTE</b> </p>	<p>The NPR is defined as the ratio of noise in a test channel when all channels are loaded with white noise to noise in the test channel when all channels except the test channel are fully noise loaded.</p> <p>The NPRF is defined as the ratio of noise in a test channel when all channels are loaded with white noise to noise in the test channel when noise loading is completely removed from the base band.</p> <p>The NPRI is defined as the ratio of noise in a test channel when all channels are loaded with white noise to noise in the test channel caused by IM power. The NPRI can be calculated one of two ways:</p> <ol style="list-style-type: none"><li><math>NPRI = NPR + \Delta</math>, where <math>\Delta</math> is obtained from a graph that relates <math>\Delta</math> to the quantity <math>(NPRF - NPR)</math>.</li><li><math>NPRI = NPR \cdot NPRF / (NPRF - NPR)</math> where all quantities are power ratios.</li></ol>
--	---

4.8.2 Test Equipment. Noise source, true rms voltmeter, audio signal generator, spectrum analyzer, noise receiver, and FM signal generator.

4.8.3 Test Method. A white-noise signal (with or without notch filter) of known amplitude is applied to the receiver under test. The output level is measured with a noise receiver and the noise ratio is calculated.

4.8.4 Setup. Connect the test equipment as shown in [Figure 4-8](#).

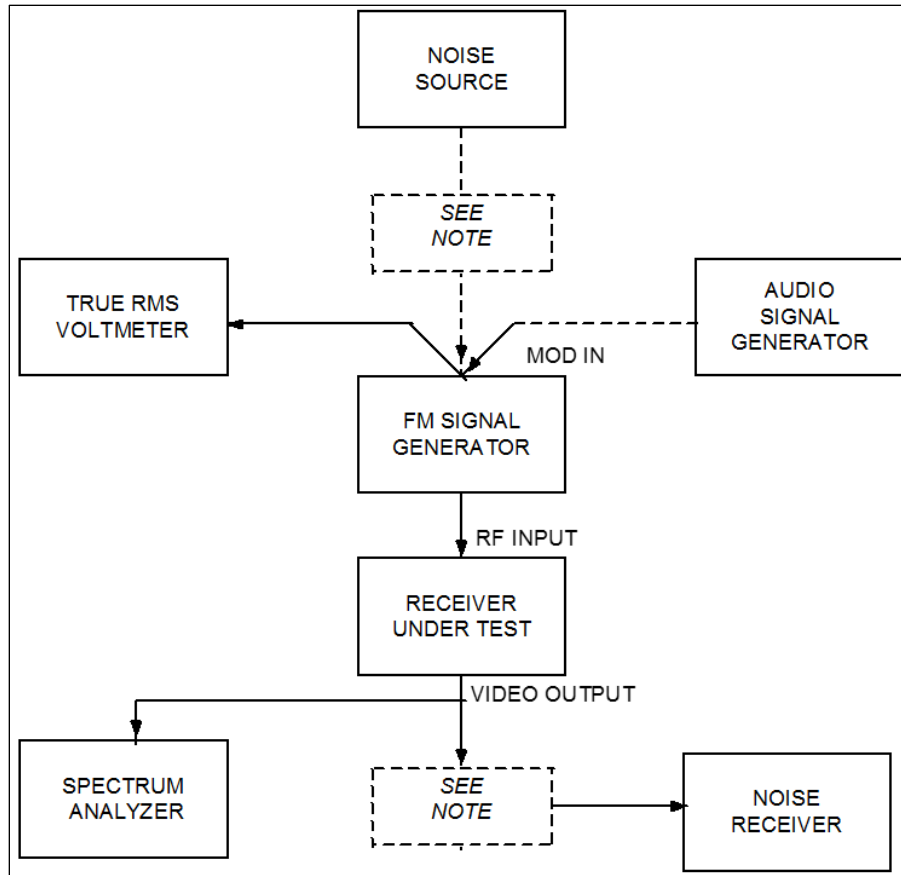



Figure 4-8. NPR Standard Test Setup

**NOTE**  Matching networks may be required at the output of the noise generator and at the input of the noise receiver if the connecting impedance differs greatly from 75 ohms. Short lengths (6 feet or less) of 50- or 93-ohm cable will not significantly affect measurement accuracy.

4.8.5 Conditions. Use the standard test conditions described in [Table 4-1](#) except as identified in [Table 4-3](#).

<b>Table 4-3. Exceptions to Standard Test Conditions</b>			
<b>IF Bandwidth (kHz)</b>	<b>Modulation Freq. NPR Base Band (kHz)</b>	<b>Video Bandwidth (dc to kHz)</b>	<b>Deviation (kHz rms)</b>
300	12–108	150–200	25
500	12–108	150–200	55
	12–156	175–300	50
	12–204	225–400	40
750	12–108	150–200	95
	12–156	175–300	85
	12–204	225–400	80
1000	12–204	225–400	125

<b>Table 4-3. Exceptions to Standard Test Conditions</b>			
<b>IF Bandwidth (kHz)</b>	<b>Modulation Freq. NPR Base Band (kHz)</b>	<b>Video Bandwidth (dc to kHz)</b>	<b>Deviation (kHz rms)</b>
1500	12–204	225–400	210
3300	12–204	225–400	530
RF input - variable (see Data Sheet 4-8)			
Demodulator bandwidth - wide (1.5 MHz)			

#### 4.8.6 Procedure

1. Record the measured data on Data Sheet 4-8.
2. Disconnect the noise generator and matching network from the FM signal generator.
3. Adjust the receiver RF input to obtain a 40-dB IF SNR by using IF SNR data obtained from the IF SNR test (see Section 4.3). If 40 dB is not obtain-able, use maximum.
4. Tune the receiver for proper reception of the input signal.
5. Use the audio signal generator to calibrate the deviation sensitivity of the FM signal generator. Set the frequency of the audio signal generator to 10 kHz and the output amplitude to 0.5 V as indicated by the true rms voltmeter.
6. Adjust the modulation level control on the FM signal generator to 140-kHz deviation as indicated by the deviation meter if the desired rms deviation is 100 kHz or less. If the desired rms deviation is more than 100 kHz, adjust the modulation level control for 710-kHz deviation as indicated by the deviation meter. These two settings represent 200-kHz rms deviation per V rms and 1000-kHz rms deviation per V rms respectively.
7. Replace the audio signal generator with the noise source at the modulation input of the FM signal generator.
8. Select the high-pass and low-pass filters for the noise source in accordance with the conditions listed in Subsection 4.8.5 to provide the appropriate base band noise for the IF bandwidth under test. To obtain the desired rms deviation, adjust the output noise voltage ( $V_1$ ) as indicated by the voltmeter for the levels listed on Data Sheet 4-8 under  $V_1$ . (These values apply only when using the equipment shown in the typical block diagram, Figure 4-8.)

	<p><b>NOTE</b> Guard against video amplifier overloading by: 1) observing the noise at the receiver video output with an oscilloscope to determine that noise spikes are not limited in amplitude, and 2) observing the video output of the receiver with the spectrum analyzer to be sure that the receiver does not exhibit spurious responses outside of the noise band pass or in the notches used in the test procedure.</p>
---	---

9. Determine the NPR for the channels shown on Data Sheet 4-8. Adjust the video output level to linear region.
10. Remove the base band noise modulation source and terminate the modulation input.
11. Use the same noise receiver reference level to again obtain NPR values for the channels shown on Data Sheet 4-8 and record these values under NPRF.

- Adjust the value of  $V_1$  required to set the remaining rms deviation levels shown on the data sheet and measure the corresponding NPR and NPRF for the channels shown on Data Sheet 4-8.
- Using the relationship  $B = \text{NPRF} - \text{NPR}$ , determine the value for  $\Delta$  from [Figure 4-9](#). Calculate the value for NPRI using the equation  $\text{NPRI} = \text{NPR} + \Delta$ .

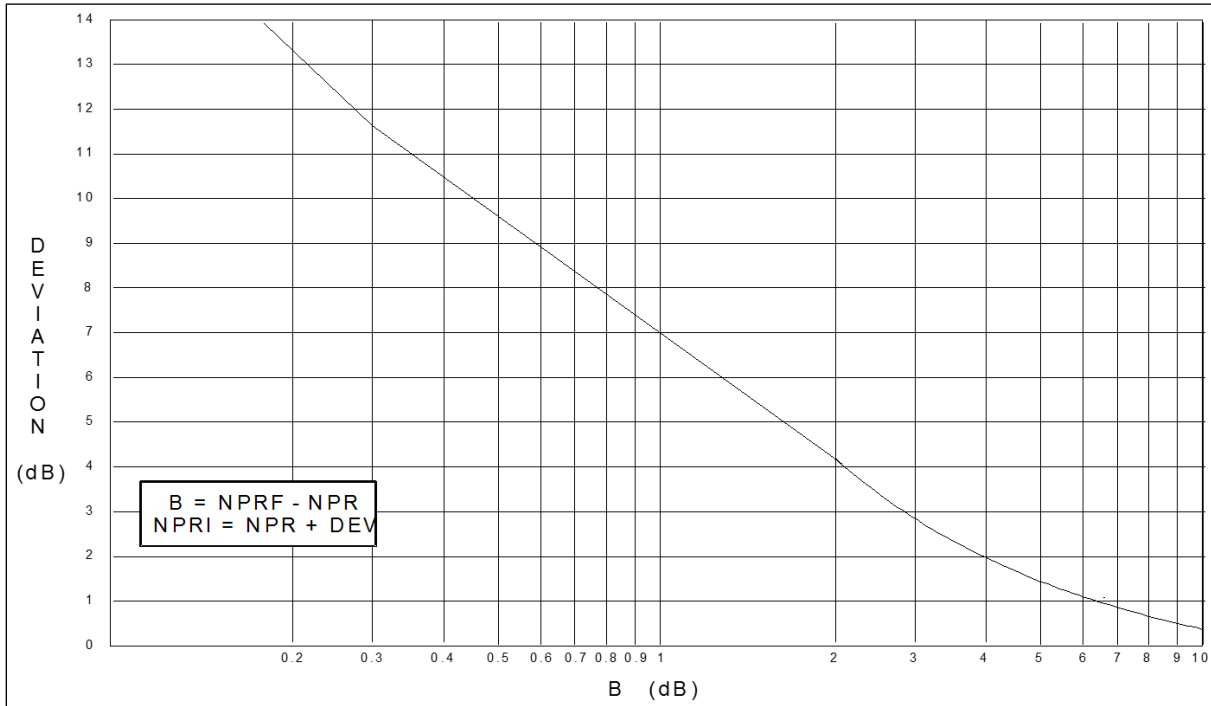

Figure 4-9. Curve for Converting NPR and NPRF Data to NPRI

- Repeat the previous measurements for other levels of IF SNR as desired. It must be pointed out, however, that the receiver may become noise floor limited at the lower IF SNR levels (that is,  $\text{NPR} = \text{NPRF}$ ). In such cases the calculation of NPRI is not possible. The measured data may be plotted as illustrated in [Figure 4-10](#).

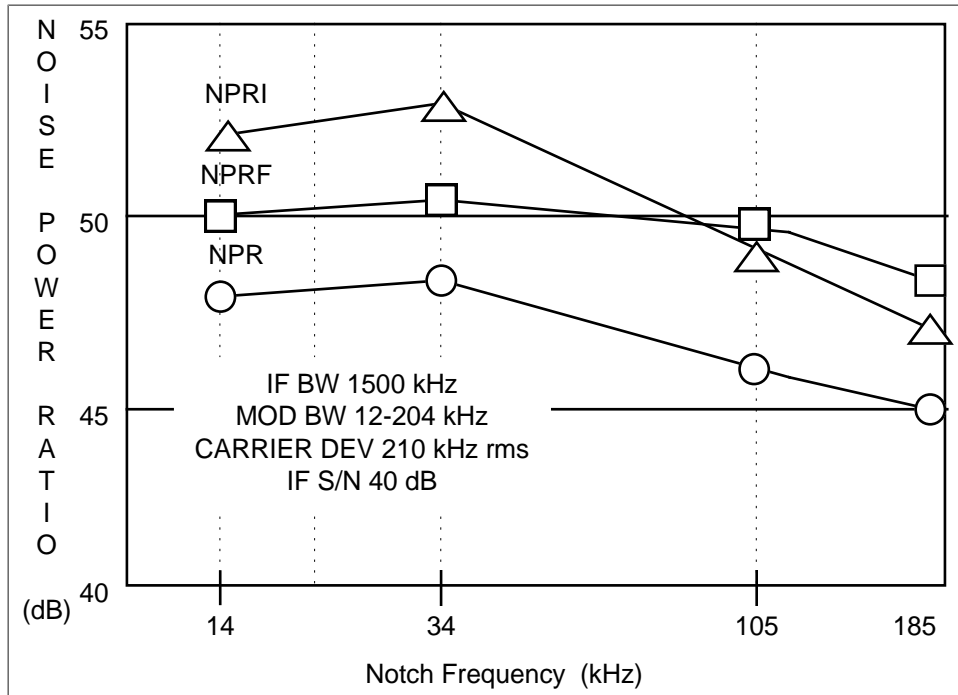

Figure 4-10. Noise Power Ratio



<b>Data Sheet 4-8. Telemetry Receivers</b>											
<b>Test 4.8</b>				<b>Noise power ratio</b>							
<b>Manufacturer:</b>				<b>Model:</b>							
<b>Serial No:</b>											
<b>Test Personnel:</b>											
<b>IF SNR = 40 dB (or max __ dB)</b>											
IF Bandwidth (kHz)	Mod Freq. Band (kHz)	Deviation (kHz rms)	V <sub>1</sub> (V rms)	NPR/NPRF (dB)				NPRI (dB)			
				Notch Freq. (kHz)				Notch Freq. (kHz)			
				14	34	70	105	14	34	70	105
300	12-108	25	0.125								
500	12-108	55	0.275								
750	12-108	95	0.475								
				14	34	70	152	14	34	70	152
500	12-156	50	0.250								
750	12-156	85	0.425								
				14	34	105	185	14	34	105	185
500	12-204	40	0.200								
750	12-204	80	0.400								
1000	12-204	125	0.125								
1500	12-204	210	0.210								
3300	12-204	530	0.530								

#### 4.9. TEST: Local Oscillator Radiation at RF Input

4.9.1 **Purpose.** This test determines if any emissions are appearing at the RF input terminals because of radiation from a local oscillator.

4.9.2 **Test Equipment.** FM signal generator, spectrum analyzer, and power meter.

4.9.3 **Test Method.** A spectrum analyzer is used to scan across the receiver band to detect any emission radiation.

4.9.4 **Setup.** Connect the test equipment as shown in [Figure 4-11](#).

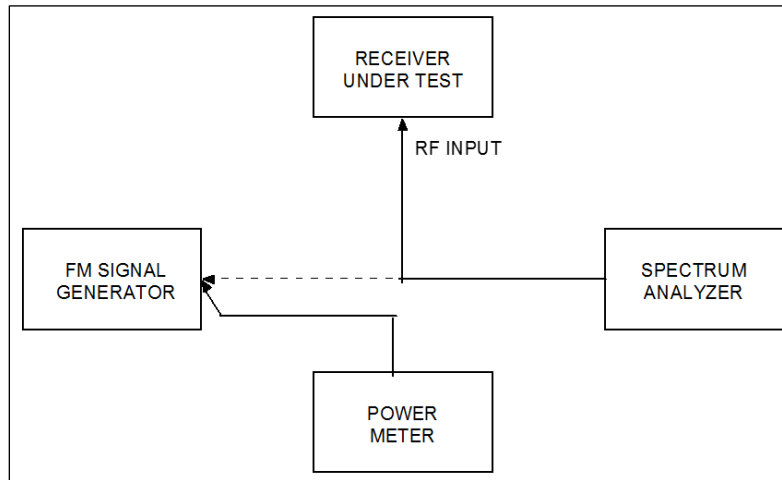







Figure 4-11. Local Oscillator Radiation Test

4.9.5 **Conditions.** Use the standard test conditions described in [Table 4-1](#). Use double shielded cable (RF 214/or equivalent) between the spectrum analyzer and the receiver RF input.

<b>NOTE</b> 	This test should be performed for all available modes of operation such as variable frequency oscillator (VFO), crystal, and synthesizer.
---	---

#### 4.9.6 Procedure

1. Tune the receiver to the desired frequency.
2. Connect the power meter to the FM signal generator output and adjust the generator frequency to correspond to the receiver tuning. Adjust the output level to  $-25$  dBm. This signal will be used to calibrate the spectrum analyzer.
3. Disconnect the power meter and connect the FM signal generator to the spectrum analyzer. Adjust the analyzer so that the  $-25$ -dBm input signal to the connecting cable appears as 0 dB on the display unit. Calibration of the spectrum analyzer should be checked at each observed frequency.
4. Remove the cable from the FM generator and connect the receiver RF input to the spectrum analyzer. Tune the spectrum analyzer slowly across the frequency range from 10 MHz to 10 GHz and record the frequency and amplitude of all signals observed.
5. Record measured data on Data Sheet 4-9.

<b>Data Sheet 4-9. Telemetry Receivers</b>			
<b>Test 4.9</b>		<b>Local oscillator radiation</b>	
<b>Manufacturer:</b>		<b>Model:</b>	
<b>Serial No:</b>			
<b>Test Personnel:</b>		<b>Date:</b>	
<b>Mode (both first and second local oscillator)</b> _____			
Frequency (MHz)	Indicated Amplitude (dBm)	Calibration Correction	Amplitude Corrected (dBm)
		 -25 dBm 	
<b>Mode (both first and second local oscillator)</b> _____			
Frequency (MHz)	Indicated Amplitude (dBm)	Calibration Correction	Amplitude Corrected (dBm)
		 -25 dBm 	

#### 4.10. TEST: Local Oscillator Stability

4.10.1 Purpose. This test determines the frequency stability of all LOs as a function of time.

4.10.2 Test Equipment. Electronic counter.

4.10.3 Setup. Connect the test equipment as shown in [Figure 4-12](#).

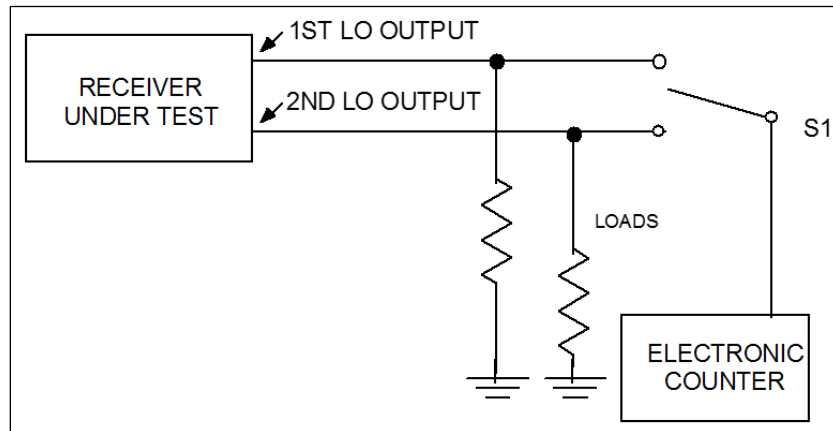

Figure 4-12. Local Oscillator Stability Test

4.10.4 Conditions. Use the standard test conditions described in [Table 4-1](#) except as follows:

Warm-up time:	none for receiver standard conditions for test equipment
RF input power:	none required
Receiver frequency:	near mid-band
First LO mode:	as stated in procedure
Second LO mode:	as stated in procedure

Disregard all other conditions.

#### 4.10.5 Procedure

1. Switch the first and second LOs to the crystal or synthesizer mode.
2. Turn on the receiver and tune to the desired frequency (preferably mid-band).
3. Turn on the receiver (cold start).
4. Measure and record the first and second local oscillator frequencies with switch S1 set to the appropriate position at the time intervals shown on Data Sheet 4-10 (crystal mode).
5. Switch the first and second LOs to the VFO mode.
6. Tune the receiver to mid-band.
7. Turn off the receiver and allow 30 minutes to cool down. Turn on the receiver (cold start).
8. Measure and record the first and second local oscillator frequencies with switch S1 set to the appropriate position at the time intervals shown on Data Sheet 4-10 (VFO mode).

#### 4.10.6 Data Reduction

1. Use the frequency obtained at the reference time to calculate the frequency change in percent for crystal and VFO modes.
2. Use the frequency measured at the reference time ( $t_r = 30$  minutes) to calculate the normal frequency ( $f_n$ ) as follows including the sign

$$f_n = f - f_r \quad (\text{Eq. 4-3})$$

The frequency change in percent for each measurement, including the direction of change as indicated by sign, is calculated as follows:

$$\% \text{ change} = \frac{f - f_r}{f_r} \bullet 100 \quad (\text{Eq. 4-4})$$

Where:

$f$  = frequency measured at a particular time

$f_r$  = frequency measured at the reference time

3. Repeat calculations for VFO mode.

<b>Data Sheet 4-10(1) (crystal mode). Telemetry Receivers</b>						
<b>Test 4.10</b>			<b>Local oscillator stability (crystal mode)</b>			
<b>Manufacturer:</b>			<b>Model:</b>			
<b>Serial No:</b>						
<b>Test Personnel:</b>						
Receiver tuned frequency _____ MHz						
Time (t) (min)	First Local Oscillator Frequency			Second Local Oscillator Frequency		
	Measured (MHz)	Normalized (f <sub>n</sub> , Hz)	Change %	Measured (MHz)	Normalized (f <sub>n</sub> , Hz)	Change %
5						
10						
15						
20						
25						
30 t <sub>r</sub>						
45						
60						
90						
120						
180						
240						
300						
360						
420						
480						
540						
600						
660						
720						

Data Sheet 4-10(2) (VFO mode). Telemetry Receivers						
Test 4.10			Local oscillator stability test (VFO mode)			
Manufacturer:			Model:			
Serial No:			Date:			
Test Personnel:						
Receiver tuned frequency _____ MHz						
Time (t) (min)	First Local Oscillator Frequency			Second Local Oscillator Frequency		
	Measured (MHz)	Normalized (f <sub>n</sub> , Hz)	Change %	Measured (MHz)	Normalized (f <sub>n</sub> , Hz)	Change %
5						
10						
15						
20						
25						
30 t <sub>r</sub>						
45						
60						
90						
120						
180						
240						
300						
360						
420						
480						
540						
600						
660						
720						

#### 4.11. TEST: Pulse Code Modulation Bit Error Rate

4.11.1 Purpose. This test measures the PCM BER as a function of the receiver IF SNR.

4.11.2 Test Equipment. RF signal generator with FM or phase modulation (PM) or both capabilities as needed, microwave counter, microwave spectrum analyzer, power splitter, PCM bit synchronizer and detector, PCM bit error rate test (BERT), oscilloscope, true rms meter, and step attenuator (1 dB steps, 100 dB attenuation minimum).

4.11.3 Test Method. This test assumes that a self-synchronizing BERT is available. The test can be performed with other test equipment with minor modifications to the procedure. This method is suitable for manual or computer controlled testing.

4.11.4 Setup. Connect the test equipment as shown in [Figure 4-13](#).

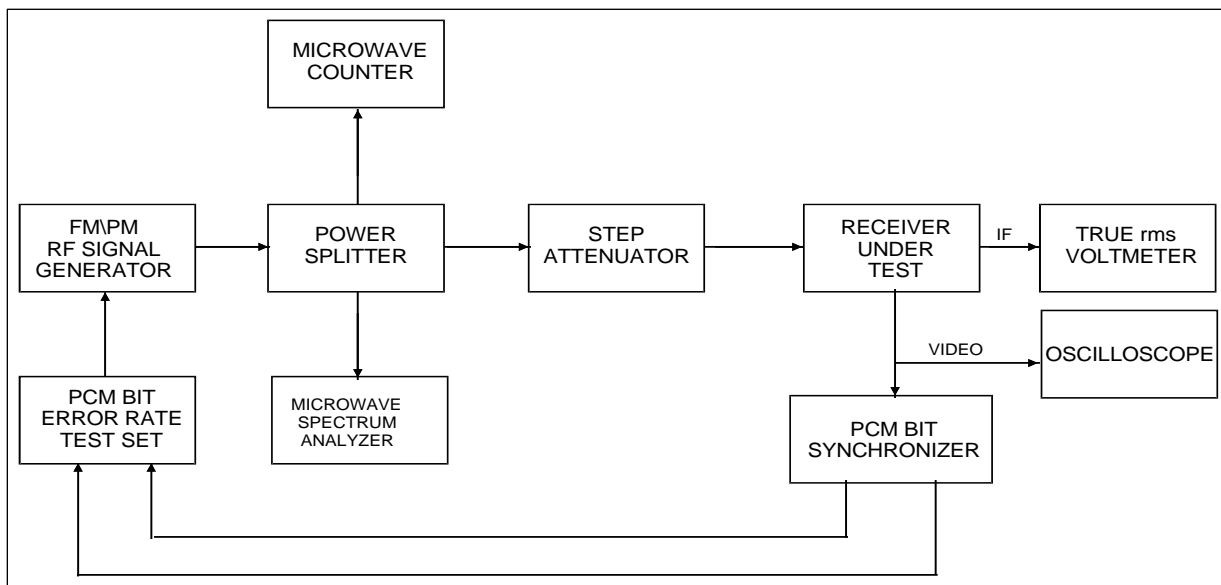

Figure 4-13. Receiver PCM Bit Error Rate

4.11.5 Conditions. Use the standard test conditions described in [Table 4-1](#). A low pass filter can be inserted between the BERT and the RF signal generator if desired.

#### 4.11.6 Procedure

1. Set the peak deviation of the RF signal generator to the value shown in [Table 4-4](#) for the PCM code and receiver demodulator type to be used in this test ( $F_B$  = bit rate). The deviation may be set using the Bessel null method or any other method preferred by the personnel conducting the test.

Table 4-4. PCM Peak Deviation for Various PCM Codes and Demodulator Types		
PCM Code	Demodulator Type	Peak Deviation
NRZ	FM	$0.35 F_B$
Biφ	FM	$0.65 F_B$
Biφ	PM	60 to 70°



NRZ-M,S	<u>PSK</u>	90° or ±1
Biφ-M,S	<u>PSK</u>	90° or ±1

2. Vary the attenuator setting until the BER is approximately  $10^{-5}$ . Decrease the attenuator (increase signal at receiver input) by 1 dB. Record this attenuator setting on Data Sheet 4-11. This setting will be the starting attenuator setting for this test.
3. Increase the RF signal applied to the TM receiver by 10 dB. Put the RF signal generator in the continuous-wave mode. Measure the amplitude of the linear IF signal using the rms voltmeter and record on Data Sheet 4-11 as the linear IF amplitude in the AGC mode. Place the receiver in MGC mode and adjust the gain to give the same IF amplitude recorded above (within ±10 percent of the value). The receiver may have an AGC freeze or hold mode that does the adjustment for you. Record this value on Data Sheet 4-11 as the IF amplitude in MGC mode. Increase the RF signal level by 6 dB. Measure the IF amplitude using the rms voltmeter and record on Data Sheet 4-11 as the +6 dB MGC amplitude. This value should be between 1.8 and 2.2 times as large as the previous MGC value. If it is not, decrease the manual gain and repeat the linearity check.
4. Return the attenuator to the starting value (see step 2). Set the manual gain to give the nominal linear IF output ±10 percent as determined in step 3 for the AGC mode. Measure and record this value on Data Sheet 4-11 as the starting value S + N. Set the attenuator to maximum attenuation. Measure the IF amplitude using the true rms voltmeter and record on Data Sheet 4-11 as the starting value N. Return the receiver to the AGC mode.
5. Set the RF signal generator to the modulation mode with the proper peak deviation. Set the attenuator and RF signal generator power to the values established in step 2 (starting value). Measure the bit errors per million bits and record on Data Sheet 4-11. An interval other than 1 million bits may be selected at the discretion of the test personnel.
6. Increase the attenuation by 1 dB. Measure the BER and record on Data Sheet 4-11. Repeat for 1 dB attenuator steps up to 10 dB.

4.11.7 Data Reduction. The receiver IF SNR (in dB) at the starting value can be calculated from (S + N and N assumed to be rms voltages).

$$(S/N)_{IF} = 10 \log_{10} (((S + N)^2 - N^2)/N^2) \quad (\text{Eq. 4-5})$$

The IF SNR referenced to a bandwidth equal to the bit rate can be calculated using

$$(S/N)_{Fb} = (S/N)_{IF} + 10 \log_{10} (ENPBW/F_B) \quad (\text{Eq. 4-6})$$

Where:

ENPBW = equivalent noise power bandwidth of the receiver IF filter  
F<sub>B</sub> = PCM bit rate

The receiver IF bandwidth can be used as an approximation to the equivalent noise power bandwidth when it is not known. Increasing the attenuation by X-dB results in an X-dB decrease in IF SNR. The measured values of BER versus IF SNR in a bandwidth equal to the bit rate can be compared to the results presented in Section 3 of RCC 119-06.

Data Sheet 4-11. Telemetry Receivers								
<b>Test 4.11</b>	<b>Pulse code modulation bit error rate</b>							
<b>Manufacturer:</b>	<b>Model:</b>							
<b>Serial No:</b>	<b>Center frequency:</b> _____ <b>MHz</b> <b>Video BW:</b> _____ <b>kHz</b>							
<b>Test Personnel:</b>								
<b>IF BW:</b> _____ <b>kHz</b>								
Final LO mode: _____ XTAL: _____ VFO: _____ AFC/APC								
Test personnel: _____ Date: _____ Location: _____								
PCM code: _____ Bit rate: _____ kbps Peak deviation: _____								
Modulation <input type="checkbox"/> FM <input type="checkbox"/> PM <input type="checkbox"/> PSK <input type="checkbox"/> Other (                    )								
Attenuator setting for $10^{-5}$ BER: _____ dB								
Linear IF amplitude in AGC mode: _____ mV rms								
IF amplitude in MGC mode: _____ mV rms								
IF amplitude in MGC mode (+6 dB): _____ mV rms								
Starting value S + N: _____ mV rms								
Starting value N: _____ mV rams								
Starting value IF SNR: _____ dB								
<table style="width: 100%; border: none;"> <tr> <td style="width: 33%; text-align: center;">Attenuator setting</td> <td style="width: 33%; text-align: center;">IF SNR (dB)</td> <td style="width: 33%; text-align: center;">Bit error rate</td> </tr> <tr> <td style="text-align: center;">_____</td> <td style="text-align: center;">_____</td> <td style="text-align: center;">_____</td> </tr> </table>			Attenuator setting	IF SNR (dB)	Bit error rate	_____	_____	_____
Attenuator setting	IF SNR (dB)	Bit error rate						
_____	_____	_____						

#### 4.12. TEST: Frequency Modulation Step Response

4.12.1 Purpose. This test measures the step response of the receiver to an input signal that is frequency modulated by pulses, for example, pulse amplitude modulation or PCM.

4.12.2 Test Equipment. An RF signal generator that can be frequency modulated, square-wave generator, microwave counter, oscilloscope, and power splitter.

4.12.3 Test Method. This test measures the frequency modulation step response of the receiver by applying an RF input signal that has been frequency modulated by a square wave.

4.12.4 Setup. Connect the test equipment as shown in [Figure 4-14](#).

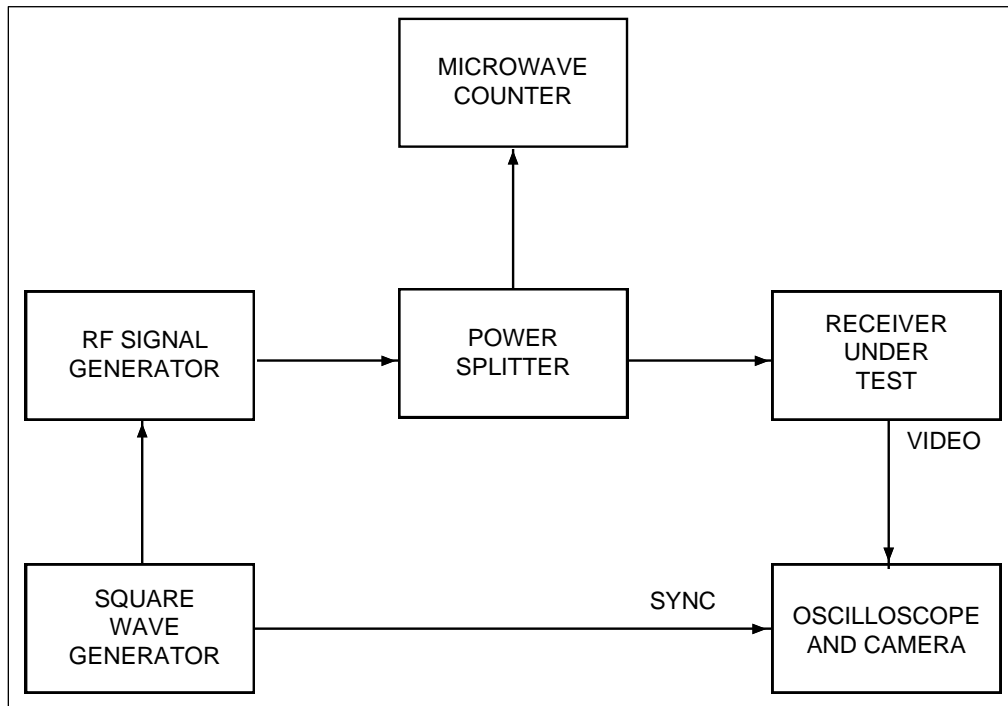

Figure 4-14. Receiver Frequency Modulation Step Response

4.12.5 Conditions. The RF signal generator output frequency should be set to the receiver's center frequency. Set the output power level to  $-50$  dBm. The step response characteristics of the square-wave generator and the RF signal generator frequency modulator must be 5 to 10 times better than the expected measured value, or the test results will not accurately reflect the receiver's FM step response.

4.12.6 Procedure. Frequency modulate the signal generator with a square wave. The square-wave frequency should be equal to 0.1 times the receiver video bandwidth (VBW). (The VBW should be less than or equal to one-half of the IF bandwidth.) The peak deviation of the RF signal generator should be 0.35 times the receiver IF bandwidth. Capture a plot of the oscilloscope display. Measure the rise time, overshoot, and settling time. Record this information on Data Sheet 4-12.

4.12.7 Data Reduction. Compare the results with the specification.

<b>Data Sheet 4-12. Telemetry Receivers</b>	
<b>Test 4.12</b>	<b>Frequency modulation step response</b>
<b>Receiver Manufacturer:</b> _____	<b>Model:</b> _____
<b>Serial No:</b> _____	
<b>Test Personnel:</b> _____	<b>Center frequency:</b> _____ <b>MHz</b>
<b>IF BW:</b> _____ <b>kHz</b>	<b>Video BW:</b> _____ <b>kHz</b>
First LO mode: _____ XTAL: _____ VFO: _____ AFC/APC	
Test personnel: _____ Date: _____ Location: _____	
<div style="text-align: center; margin-top: 100px;"> <p>Rise Time: _____microseconds</p> <p>Overshoot: _____percent</p> <p>Settling Time: _____microseconds</p> </div>	

#### 4.13. TEST: Receiver Band Pass Frequency Response using Unmodulated Signal

4.13.1 Purpose. This test measures the effective receiver band pass bandwidth.

4.13.2 Test Equipment. An RF signal generator, microwave counter, true rms voltmeter, RF counter (optional), wave analyzer (optional), and power splitter.

4.13.3 Test Method. This test measures receiver bandwidth by fixing the receiver gain, varying the input frequency, and measuring the linear IF output amplitude. This test works well for receivers that have stable MGC and linear IF output. This test is suitable for manual or computer controlled testing.

4.13.4 Setup. Connect the test equipment as shown in [Figure 4-15](#). The rms voltmeter can be used to test for less than 30 dB of filter attenuation. The wave analyzer and RF counter must be used for tests where greater attenuation is to be measured.

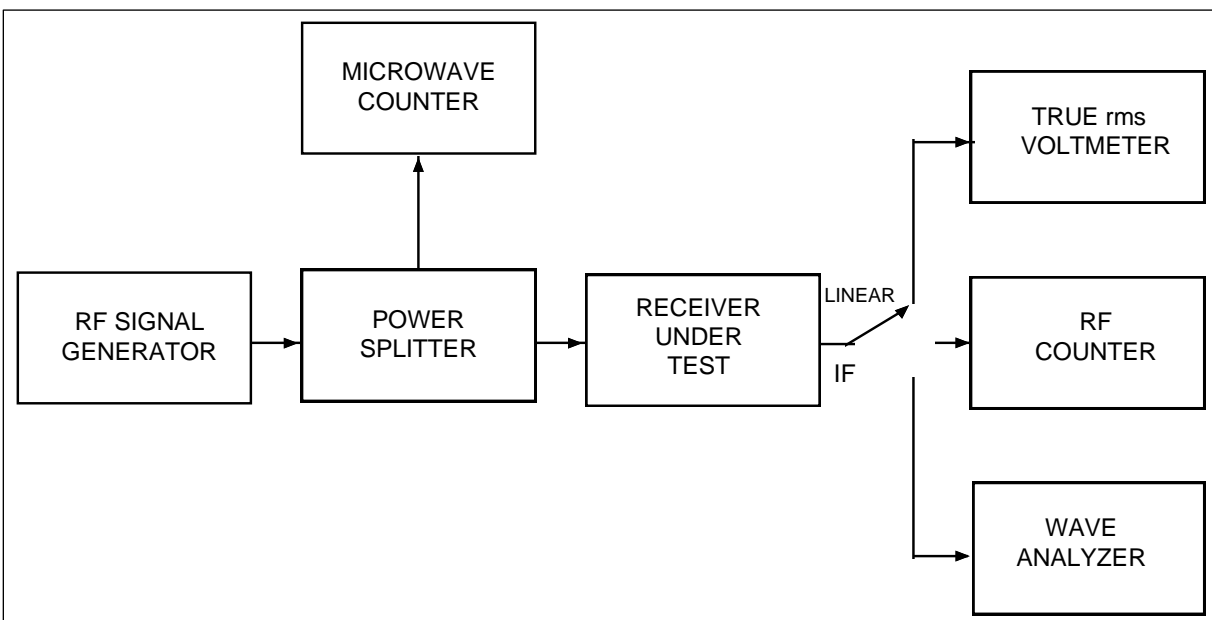

Figure 4-15. Receiver Band Pass Response using Unmodulated Signal

4.13.5 Conditions. The RF signal generator frequency should be set to the receiver center frequency. The output power should be set to give a receiver IF SNR of greater than 30 dB, however, do not saturate the receiver. The receiver local oscillator should be in crystal or synthesizer mode whenever possible. Automatic frequency control (AFC) modes cannot be used for this test. The wave analyzer band pass filter should be set to approximately 3 kHz. The receiver gain must remain fixed for the duration of the test. The gain of many receivers drifts with time. This test will not work with a wave analyzer if the RF signal generator or receiver under test has excessive PM or frequency drift.

##### 4.13.6 Procedure

1. Measure the amplitude of the signal at the output of the linear IF with the receiver in the AGC mode. Put the receiver in the MGC mode and set the linear IF output amplitude to a value approximately equal to the value measured in the AGC mode. Increase the RF generator output power by 6 dB. The linear IF output amplitude should increase by  $6 \pm 0.5$

dB. If it does not, decrease the linear IF output amplitude by 6 dB using the MGC and repeat until this condition is satisfied.

2. Set the RF generator to its original power level and measure the linear IF amplitude (MGC mode). Disconnect the RF generator and measure the linear IF output amplitude. (This step can be skipped if the wave analyzer is used.) Record this value on Data Sheet 4-13 as the baseline noise level.
3. Reconnect the RF generator to the receiver under test. If the wave analyzer is to be used in this test, count the frequency of the receiver IF output. Record on Data Sheet 4-13 as the center frequency IF output frequency. This value will be used to calculate the measurement frequencies for the wave analyzer.
4. Increase the RF generator frequency by 10 kHz. Measure the linear IF output frequency. If it increased by 10 kHz, the receiver IF output tracks the input. If it decreased by 10 kHz, the receiver IF output frequency change is opposite to the input change. If the frequency changes by some other amount, a problem exists and an investigation is necessary.
5. Set the RF generator to a frequency equal to the receiver center frequency minus two times the IF bandwidth (minus one times the IF bandwidth if a true rms voltmeter is used). Set the wave analyzer to a frequency equal to the IF frequency measured in step 3 minus two times the IF bandwidth if the IF frequency tracks the input frequency (plus two times the IF bandwidth if the IF frequency change is opposite to the input frequency change). Measure the amplitude of the linear IF output (using true rms voltmeter or wave analyzer) and record on Data Sheet 4-13 along with the RF input frequency.
6. Increase the RF generator frequency by 0.25 times the receiver IF bandwidth setting. Set the wave analyzer frequency to the calculated IF frequency. Measure the amplitude of the linear IF output and record on Data Sheet 4-13 along with the RF input frequency. Repeat this step until the RF generator frequency is equal to the receiver center frequency plus two times the IF bandwidth (plus one times the IF bandwidth if a true rms voltmeter is used).

 <p><b>NOTE</b></p>	<p>This test can be performed with any frequency step size that is desired. A quick test can be performed with a step size of 0.5 times the receiver IF bandwidth setting. A test that measures the IF response in more detail may use a step size of 0.05 or 0.1 times the receiver IF bandwidth setting.</p>
--	--

#### 4.13.7 Data Reduction

1. The rms voltmeter readings can be corrected for background noise by subtracting the background noise power (voltage squared) from the measured values. If the measured value was 7.4 mV rms and the background noise was 4.8 mV rms, the signal amplitude was

$$\sqrt{7.42^2 - 4.82^2} = \sqrt{54.76 - 23.04} = 5.63 \text{ mV.} \quad (\text{Eq. 4-7})$$

The wave analyzer values do not need to be corrected because the 3 kHz band pass filter does not pass much noise and the noise power decreases beyond the receiver IF filter band edges.

2. The 3-dB bandwidth of the IF filter can be calculated by finding the input frequencies where the signal was attenuated by slightly more than 3 dB with respect to the signal at center

frequency. Perform a linear interpolation between this frequency and the adjacent frequency where the signal was attenuated by slightly less than 3 dB to find the approximate upper and lower 3 dB frequencies. That is, if the signal was attenuated by  $A_1$  dB at frequency  $f_1$  and  $A_2$  dB at frequency  $f_2$ , the approximate 3 dB frequency would be

$$f_1 + \frac{A_1 - 3}{A_1 - A_2} (f_2 - f_1) \quad (\text{Eq. 4-8})$$

Let  $f_1 = 10.45$  MHz,  
 $f_2 = 10.5$  MHz,  
 $A_1 = 2.2$  dB,  
 $A_2 = 3.2$  dB,

then  $f_{-3 \text{ dB}} = 10.45 + \{(2.2 - 3)/(2.2 - 3.2)\} \cdot (10.5 - 10.45) = 10.49$  MHz.

3. The receiver IF filter equivalent noise power bandwidth with respect to the center frequency can be calculated by dividing the measured power at each frequency by the measured power at the center frequency and then multiplying each of these values by the frequency step size and adding all of these values.

<b>Data Sheet 4-13. Telemetry Receivers</b>		
<b>Test 4.13</b>	<b>Receiver band pass frequency response using unmodulated signal</b>	
<b>Manufacturer:</b> _____	<b>Model:</b> _____	
<b>Serial No:</b> _____		
<b>Test Personnel:</b> _____	<b>Center frequency:</b> _____ <b>MHz</b>	
<b>IF BW:</b> _____ <b>kHz</b>	<b>Video BW:</b> _____ <b>kHz</b>	
Final LO mode: _____ XTAL: _____ VFO: _____		
Test personnel: _____ Date: _____ Location: _____		
Baseline noise level: _____ Center frequency IF output frequency: _____		
<b>RF input frequency</b>	<b>Linear IF output amplitude</b>	<b>Corrected linear IF output amplitude</b>
_____	_____	_____
Upper -3 dB frequency	_____	
Lower -3 dB frequency	_____	
-3 dB bandwidth	_____	
Equivalent noise power bandwidth	_____	



#### 4.14. TEST: Receiver Band Pass Frequency Response using Phase-Modulated Signal

4.14.1 Purpose. This test measures the effective receiver band pass bandwidth.

4.14.2 Test Equipment. An RF signal generator with PM capability, sine-wave generator, microwave counter, microwave spectrum analyzer, RF counter, wave analyzer (or spectrum analyzer), and power splitter.

4.14.3 Test Method. This method measures receiver bandwidth using a phase-modulated carrier. It takes advantage of the principle that the amplitudes of the Bessel sidebands of a PM carrier do not change with the modulating frequency (phase deviation held constant). The method is especially well suited to automated testing. It is not recommended for manual testing. This method also works for receivers that do not have MGC.

4.14.4 Setup. Connect the equipment as shown in [Figure 4-16](#).

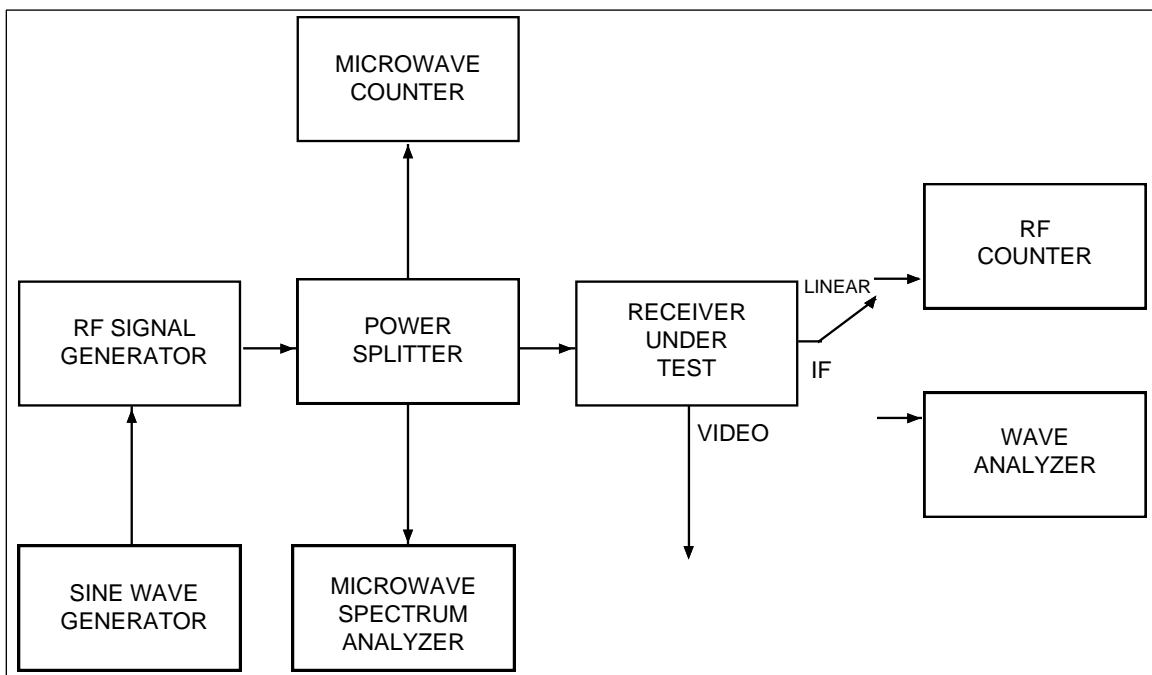

Figure 4-16. Receiver Band Pass Response using Phase-Modulated Signal

4.14.5 Conditions. The RF signal generator should be set to

Output frequency: receiver center frequency

Output power: sufficient to give >30-dB IF SNR or as desired.

The wave analyzer (or spectrum analyzer) RBW should be set to 3 kHz. For narrow IF bandwidths, use an RBW no wider than 0.03 times the receiver IF bandwidth.

4.14.6 Procedure

1. The first step in this procedure will be to set the peak phase deviation to approximately  $82^\circ$ . Increase the amplitude of the sine-wave generator (frequency = 10 kHz), while monitoring RF signal using spectrum analyzer, until the carrier component and the first order sidebands are equal in amplitude. The second order sidebands should be approximately 8 dB lower in

amplitude. Increase the sine-wave generator frequency to a value equal to two times the receiver IF bandwidth. Verify that the amplitudes of the carrier component and the first order sidebands are within  $\pm 1$  dB of each other. If they are not within  $\pm 1$  dB, the RF generator does not have sufficient bandwidth to perform this test.

 <p><b>NOTE</b></p>	<p>This method will not work if the RF signal generator or receiver under test has excessive incidental phase, frequency modulation, or frequency drift.</p>
--	--

- Set the sine-wave generator to a frequency equal to 0.05 times the receiver IF bandwidth (50 kHz for a 1 MHz IF bandwidth). Measure and record the frequency of the carrier component and the amplitudes of the carrier component and both first order sidebands at the receiver linear IF output.  $F_C$  represents carrier frequency translated to the receiver IF and  $F_M$  represents modulating frequency; therefore, the frequency of the lower first order sideband is  $F_C - F_M$ . Increase the sine-wave generator frequency in steps of 0.05 times the receiver IF bandwidth. The maximum frequency will be two times the receiver IF bandwidth. Measure and record on Data Sheet 4-14 the amplitudes of the carrier component and both first order sidebands. Sample Data Sheet 4-14 is included to show calculations.

#### 4.14.7 Data Reduction

- Average the values of the first order sideband amplitudes at a modulation frequency of 0.05 times the IF bandwidth. Subtract this value from the amplitude of the carrier component with this modulating frequency. Use this value as a correction value for all other data points. Subtract the amplitude of the carrier component from each sideband amplitude and add the correction value. Repeat for all modulating frequencies.
- The 3 dB bandwidth of the IF filter can be calculated by finding the input frequencies where the signal was attenuated by slightly more than 3 dB with respect to the signal at center frequency. Perform a linear interpolation between this frequency and the adjacent frequency, where the signal was attenuated by slightly less than 3 dB, to find the approximate upper and lower 3 dB frequencies. That is, if the signal was attenuated by  $A_1$  dB at frequency  $f_1$  and  $A_2$  dB at frequency  $f_2$ , the approximate  $-3$  dB frequency would be

$$f_1 + \frac{A_1 - 3}{A_1 - A_2} (f_2 - f_1) \quad (\text{Eq. 4-9})$$

Let:  $f_1 = 10.45$  MHz,  
 $f_2 = 10.5$  MHz,  
 $A_1 = 2.2$  dB,  
 $A_2 = 3.2$  dB,

then  $f_{-3 \text{ dB}} = 10.45 + \{(2.2 - 3)/(2.2 - 3.2)\} (10.5 - 10.45) = 10.49$  MHz.

- The receiver IF filter equivalent noise power bandwidth with respect to the center frequency can be calculated by dividing the measured power at each frequency by the measured power at the center frequency and then multiplying each of these values by the frequency step size and adding all of these values.

<b>Data Sheet 4-14. Telemetry Receivers</b>			
<b>Test 4.14</b>	<b>Receiver band pass frequency response using a phase-modulated signal</b>		
<b>Manufacturer:</b>	<b>Model:</b>		
<b>Serial No:</b>			
<b>Test Personnel:</b>	<b>Center frequency:</b> _____ <b>MHz</b>		
<b>IF BW:</b> _____ <b>kHz</b>	<b>Video BW:</b> _____ <b>kHz</b>		
Final LO mode: _____ XTAL: _____ VFO: _____			
Test personnel: _____ Date: _____ Location: _____			
Measured frequency at receiver IF output (F <sub>C</sub> ) _____ kHz			
Modulating Frequency	F <sub>C</sub> Amplitude (dB)	FC – FM Amplitude (dB)	FC + FM Amplitude (dB)
_____	_____	_____	_____
_____	_____	_____	_____
Upper –3 dB frequency _____			
Lower –3 dB frequency _____			
–3 dB bandwidth _____			
Equivalent noise power bandwidth _____			

Data Sheet 4-14 (SAMPLE).		Telemetry Receivers	
<b>Test 4.14</b>	<b>Receiver band pass frequency response using a phase-modulated signal</b>		
<b>Manufacturer:</b>		<b>Model:</b>	
<b>Serial No:</b> <u>366</u>			
<b>Test Personnel:</b>		<b>Center frequency:</b>	<u>2250.5</u> MHz
<b>IF BW:</b>	<u>1000</u> kHz	<b>Video BW:</b>	<u>500</u> kHz
Final LO mode: _____ XTAL: <u>X</u> VFO: _____			
Test personnel: _____ Date: <u>4/16/89</u> Location: _____			
Measured frequency at receiver IF output (F <sub>C</sub> ) <u>20000</u> kHz			
Modulating Frequency	FC Amplitude (dB)	FC – FM Amplitude (dB)	FC + FM Amplitude (dB)
50 kHz	-12.98	-13.16	-13.24
450 kHz	-10.98	-13.52	-14.07
500 kHz	-10.58	-13.85	-14.52
1000 kHz	-8.04	-26.51	-28.22
1500 kHz	-7.92	-49.19	-51.27
2000 kHz	-7.94	-69.50	-70.72
Upper -3 dB frequency <u>20 458</u> kHz			
Lower -3 dB frequency <u>19 504</u> kHz			
-3 dB bandwidth <u>954</u> kHz			
Equivalent noise power bandwidth <u>972</u> kHz			

#### 4.15. TEST: Receiver Band Pass Frequency Response using White-noise Input

4.15.1 Purpose. This test measures the effective receiver band pass bandwidth.

4.15.2 Test Equipment. Spectrum analyzer (or wave analyzer) with RBW <10% of specified receiver band pass filter bandwidth and effective VBW of <1% of RBW, white-noise generator, and oscilloscope camera or plotter for recording spectrum analyzer display.

4.15.3 Test Method. This method measures receiver bandwidth using a white-noise input signal. A TM preamplifier with a terminated input can be used as a noise generator. This test can also be performed with the receiver RF input terminated. The results may change depending on the amount of noise generated in various sections of the receiver. This test can be performed with receivers in the AGC mode and can also be performed on receivers with only a limited IF output. This test is suited for both manual and computer controlled testing.

4.15.4 Setup. Connect the test equipment as shown in [Figure 4-17](#).

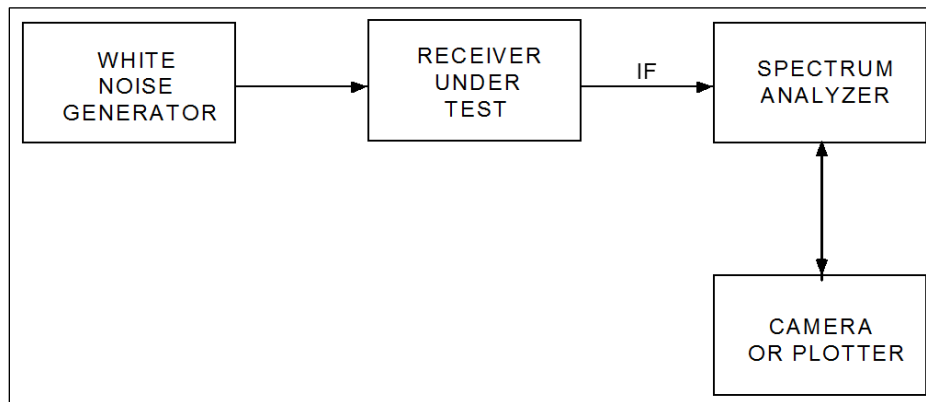

Figure 4-17. Receiver Band Pass Response using White Noise

4.15.5 Conditions. Set the spectrum analyzer center frequency to the receiver IF output center frequency. Set the spectrum analyzer sweep width to sweep from IF center frequency minus two times specified IF bandwidth to IF center frequency plus two times specified IF bandwidth. For a receiver with a 10 MHz IF output and a 1 MHz IF bandwidth, the spectrum analyzer would be set to sweep from 8 MHz to 12 MHz with a 30-kHz RBW (100 kHz optional) and a 300-Hz VBW. If the spectrum analyzer only has certain span settings, use the smallest setting that is greater than or equal to the calculated setting.

4.15.6 Procedure. Measure and record the noise spectrum at the receiver IF output. Estimate the gain (loss) at the frequencies listed on Data Sheet 4-15. Attach the photograph or plot to the data sheet.

4.15.7 Data Reduction. Estimate (calculate) the  $-3$ -dB bandwidth of the receiver band pass output. Record this value on Data Sheet 4-15.

<b>Data Sheet 4-15. Telemetry Receivers</b>																			
<b>Test 4.15</b>	<b>Receiver band pass frequency response using white-noise input</b>																		
<b>Manufacturer:</b>		<b>Model:</b>																	
<b>Serial No:</b>																			
<b>Test Personnel:</b>		<b>Center frequency:</b>	_____ <b>MHz</b>																
<b>IF BW:</b>	_____ <b>kHz</b>	<b>Video BW:</b>	_____ <b>kHz</b>																
Final LO mode: _____ XTAL: _____ VFO: _____																			
Test personnel: _____ Date: _____ Location: _____																			
<table border="1" style="margin: auto; border-collapse: collapse; width: 80%;"> <thead> <tr> <th style="padding: 5px;">Frequency</th> <th style="padding: 5px;">Amplitude (dB)</th> </tr> </thead> <tbody> <tr><td style="padding: 5px;"><math>F_0</math></td><td style="padding: 5px;"></td></tr> <tr><td style="padding: 5px;"><math>F_0 - BW/2</math></td><td style="padding: 5px;"></td></tr> <tr><td style="padding: 5px;"><math>F_0 + BW/2</math></td><td style="padding: 5px;"></td></tr> <tr><td style="padding: 5px;"><math>F_0 - BW</math></td><td style="padding: 5px;"></td></tr> <tr><td style="padding: 5px;"><math>F_0 + BW</math></td><td style="padding: 5px;"></td></tr> <tr><td style="padding: 5px;"><math>F_0 - 2 BW</math></td><td style="padding: 5px;"></td></tr> <tr><td style="padding: 5px;"><math>F_0 + 2 BW</math></td><td style="padding: 5px;"></td></tr> </tbody> </table>				Frequency	Amplitude (dB)	$F_0$		$F_0 - BW/2$		$F_0 + BW/2$		$F_0 - BW$		$F_0 + BW$		$F_0 - 2 BW$		$F_0 + 2 BW$	
Frequency	Amplitude (dB)																		
$F_0$																			
$F_0 - BW/2$																			
$F_0 + BW/2$																			
$F_0 - BW$																			
$F_0 + BW$																			
$F_0 - 2 BW$																			
$F_0 + 2 BW$																			
$F_0 =$ IF center frequency		$BW =$ IF bandwidth (-3 dB)																	
Estimated -3-dB bandwidth _____																			

#### 4.16. TEST: Data Frequency Response

4.16.1 Purpose. This test measures the data frequency response of a TM receiver.

4.16.2 Test Equipment. Sine-wave generator, RF signal generator that can be frequency modulated or phase-modulated or both, microwave counter, oscilloscope, rms voltmeter, and microwave spectrum analyzer.

4.16.3 Test Method. This test measures data frequency response by measuring the receiver video output level while varying the modulation frequency. The carrier deviation is kept at a constant value.

4.16.4 Setup. Connect the test equipment as shown in [Figure 4-18](#).

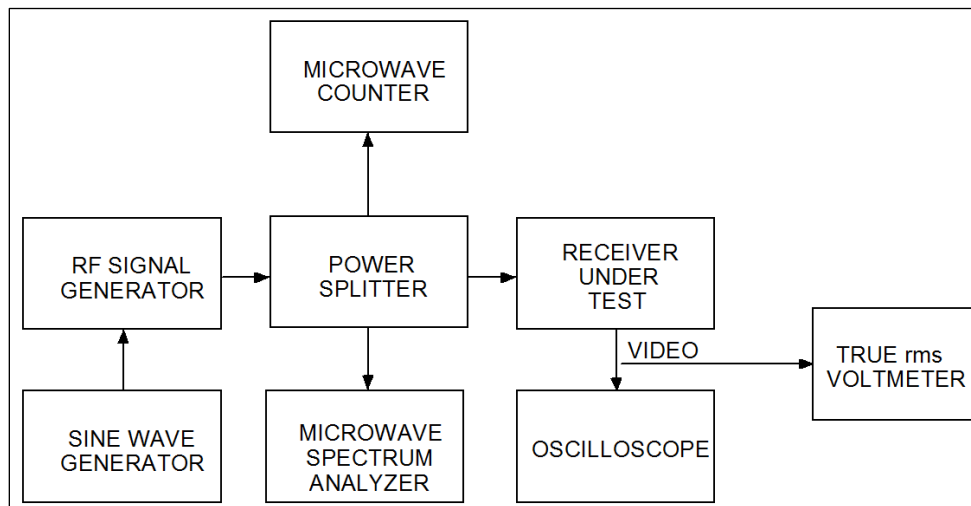

Figure 4-18. Receiver Data Frequency Response

4.16.5 Conditions. The signal generator should be set to

Output frequency: receiver center frequency  
Output amplitude: sufficient to give >30-dB IF SNR.

The receiver video output should be set to approximately 0 Vdc with an unmodulated center frequency input.

4.16.6 Procedure

1. The first step in this procedure will be to set the RF signal generator peak deviation. If a receiver with an FM demodulator is being used, set the peak deviation equal to the selected VBW. (The IF bandwidth should be at least twice the VBW.) The peak deviation can be set using Bessel nulls or whatever method is familiar to the test operator. If a receiver with a PM demodulator is being used, set the peak deviation to  $82^\circ$ . Set the sine-wave oscillator frequency to two times the VBW. Measure the difference (in dB) between the modulated carrier amplitude and the amplitudes of the first sideband pair. This difference should be 11.8 dB for frequency modulation (sidebands lower than modulated carrier) and 0 dB for PM. If both sidebands are not between 10.8 and 12.8 dB ( $\pm 1$  dB for PM) lower than the modulated carrier, the frequency response of the signal generator is not adequate for this test, and a different signal generator must be used.

 <b>NOTE</b>	This test can also be performed using a spectrum analyzer with tracking generator in place of the sine-wave generator and true rms voltmeter.
---	---

2. Set the sine-wave oscillator frequency to one-tenth of the receiver VBW. Maintain the sine-wave oscillator amplitude equal to the value determined in step 1. Measure the output on the rms voltmeter and record on Data Sheet 4-16.
3. Increase the sine-wave oscillator frequency (amplitude held constant) in steps of one-tenth of the receiver VBW. The highest sine-wave oscillator frequency will be equal to twice the receiver VBW. Measure and record the video output on Data Sheet 4-16 for each frequency.

4.16.7 Data Reduction. Subtract the video output amplitude (in dB) at one-tenth the VBW from the amplitude at each of the other frequencies. Record on Data Sheet 4-16.



<b>Data Sheet 4-16. Telemetry Receivers</b>			
<b>Test 4.16</b>	<b>Data frequency response</b>		
<b>Manufacturer:</b> _____		<b>Model:</b> _____	
<b>Serial No:</b> _____		<b>Center frequency:</b> _____ <b>MHz</b>	
<b>IF BW:</b> _____ <b>kHz</b>		<b>Video BW:</b> _____ <b>kHz</b>	
Final LO mode: _____ XTAL: _____ VFO: _____ AFC/APC			
FM _____ PM _____ Other ( _____ )			
Test personnel: _____ Date: _____ Location: _____			
Video Bandwidth (VBM)	Frequency	Amplitude (dB)	Relative Amplitude (dB)
0.1			
0.2			
0.3			
0.4			
0.5			
0.6			
0.7			
0.8			
0.9			
1.0			
1.1			
1.2			
1.3			
1.4			
1.5			
1.6			
1.7			
1.8			
1.9			
2.0			

#### 4.17. TEST: Automatic Gain Control Stability

- 4.17.1 Purpose. This test measures the stability of the receiver AGC system versus time.
- 4.17.2 Test Equipment. Chart recorder, dc voltmeter, RF generator (optional), microwave counter (optional), and power splitter (optional).
- 4.17.3 Test Method. This test measures and records the variations in AGC over a specified time interval with no input signal applied to the receiver. This test can also be performed with a stable, non-saturating RF signal applied to the receiver input.
- 4.17.4 Setup. Connect the test equipment as shown in [Figure 4-19](#).

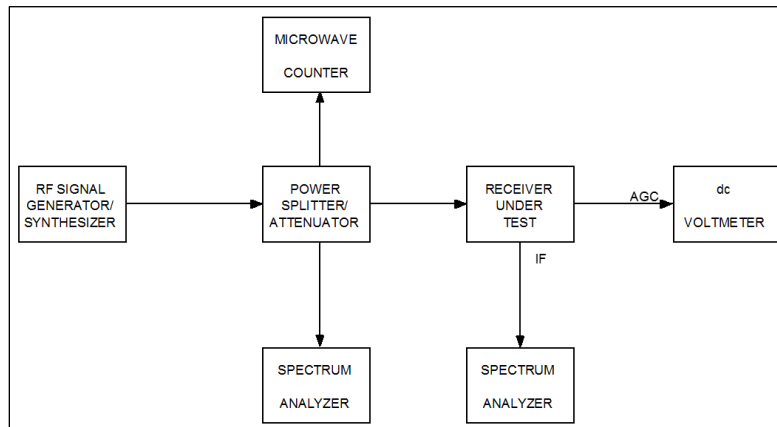

Figure 4-19. Receiver AGC Stability

- 4.17.5 Conditions. The receiver should be turned on before the start of the test for the specified warm-up time. The RF generator (if used) must also be stabilized before the test is started. The RF generator should be set to the receiver center frequency.
- 4.17.6 Procedure. Start the pen recorder and record the receiver AGC voltage for the length of time desired. (Eight hours is a reasonable time interval.) If a computer controlled test system is available, read the dc voltmeter on a periodic basis, and store the data. At least 100 readings should be taken during the test. Record the total test time and the starting and ending AGC values on Data Sheet 4-17.
- 4.17.7 Data Reduction. Find the maximum and minimum values of AGC voltage. Record these values on Data Sheet 4-17. Subtract the minimum value from the maximum value and record this value as the total change during the test interval.

<b>Data Sheet 4-17. Telemetry Receivers</b>													
<b>Test 4.17</b>	<b>Automatic gain control stability</b>												
<b>Manufacturer:</b>	<b>Model:</b>												
<b>Serial No:</b>	<b>Center frequency:</b> _____ <b>MHz</b>												
<b>IF BW:</b> _____ <b>kHz</b>	<b>AGC time constant:</b> _____ <b>ms</b>												
Final LO mode: _____ XTAL: _____ VFO: _____ AFC/APC FM _____ PM _____ Other ( _____ )													
Test personnel: _____ Date: _____ Location: _____													
<table border="1" style="margin: auto; border-collapse: collapse; width: 80%;"> <tbody> <tr> <td style="padding: 5px;">Total test time</td> <td style="width: 150px;"></td> </tr> <tr> <td style="padding: 5px;">AGC voltage at start of test</td> <td></td> </tr> <tr> <td style="padding: 5px;">AGC voltage at end of test</td> <td></td> </tr> <tr> <td style="padding: 5px;">Maximum AGC voltage</td> <td></td> </tr> <tr> <td style="padding: 5px;">Minimum AGC voltage</td> <td></td> </tr> <tr> <td style="padding: 5px;">Total change (maximum – minimum)</td> <td></td> </tr> </tbody> </table>		Total test time		AGC voltage at start of test		AGC voltage at end of test		Maximum AGC voltage		Minimum AGC voltage		Total change (maximum – minimum)	
Total test time													
AGC voltage at start of test													
AGC voltage at end of test													
Maximum AGC voltage													
Minimum AGC voltage													
Total change (maximum – minimum)													

#### 4.18. TEST: Receiver Video Spurious Outputs

4.18.1 Purpose. This test measures the amplitude of any spurious signals at the demodulator output.

4.18.2 Test Equipment. An RF signal generator with FM or PM or both capabilities, sine-wave generator, microwave spectrum analyzer, low frequency spectrum analyzer or wave analyzer, oscilloscope, microwave counter, and power splitter.

4.18.3 Test Method. The video output spectrum is monitored for discrete output signals with a strong, unmodulated input signal.

4.18.4 Setup. Connect the test equipment as shown in [Figure 4-20](#).

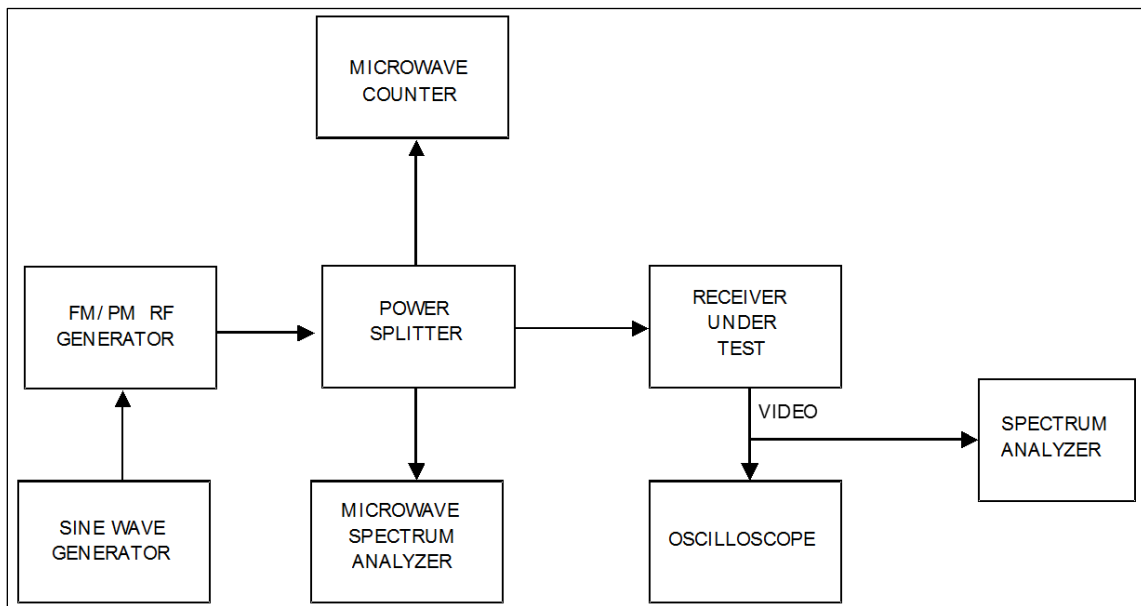

Figure 4-20. Receiver Video Spurious Outputs

4.18.5 Conditions. Set the RF signal generator frequency to the receiver center frequency. Set the RF generator output power to  $-50$  dBm. The receiver IF bandwidth and video output filter should be set to their widest settings.

#### 4.18.6 Procedure

1. Adjust the amplitude of the sine-wave generator to produce a peak frequency deviation of 100 kHz if an FM demodulator is being tested or a peak phase deviation of 1 radian if a PM demodulator is being tested. This deviation can be checked by modulating with a 100-kHz sine wave. The modulation index will be 1 for both FM and PM. At a modulation index of 1, the first-order sideband pair should both be attenuated by approximately 4.8 dB with respect to the carrier, and the second order pair should be approximately 16.5 dB lower than the carrier.
2. Tune the receiver to center the input signal if necessary. Measure the amplitude at the receiver video output at a frequency of 100 kHz with the RBW of the spectrum analyzer (or wave analyzer) set to 1 or 3 kHz (whichever is available). Record this value on Data Sheet 4-18 as the measurement reference.

3. Set the RF generator to the continuous-wave mode. Verify that no spectral sideband components are within  $\pm 1$  receiver IF bandwidth of the RF generator center frequency. If any components produced by angle modulation are present, they will appear at the receiver video output.
4. Measure the amplitude and frequency of any discrete signals in the receiver video output. Record these values on Data Sheet 4-18.
5. Monitor the receiver video output on the oscilloscope. Check for low frequency signals that the spectrum analyzer could not resolve, such as 60 Hz and multiples thereof. Record the approximate amplitude and frequency of any low-frequency signals on Data Sheet 4-18.

4.18.7 Data Reduction. Convert the amplitudes of the signals measured in step 4 to effective peak deviation by using one of the following equations:

Measurements in dBm and dBV:

$$\text{Effective peak deviation} = 10^z \cdot \text{reference peak deviation} \quad (\text{Eq. 4-10})$$

Measurements in volts:

$$\text{Effective peak deviation} = \frac{A_i}{A_{\text{ref}}} \cdot \text{reference peak deviation} \quad (\text{Eq. 4-11})$$

Where:

$A_i$  = amplitude measured in step 4

$A_{\text{ref}}$  = amplitude measured in step 2

$z$  =  $(A_i - A_{\text{ref}})/20$

Reference peak deviation = 100 kHz or 1 radian

The effective peak deviation of signals measured in step 5 can be calculated using these equations provided the amplitudes are converted to the same units used to make the reference measurement.

<b>Data Sheet 4-18. Telemetry Receivers</b>		
<b>Test 4.18</b>	<b>Receiver video spurious outputs</b>	
<b>Manufacturer:</b>	<b>Model:</b>	
<b>Serial No:</b>	<b>Center frequency:</b> _____ <b>MHz</b>	
<b>IF BW:</b> _____ <b>kHz</b>	<b>Video BW:</b> _____ <b>kHz</b>	
Final LO mode: _____ XTAL: _____ VFO: _____ AFC/APC		
Test personnel: _____	Date: _____	Location: _____
Demodulator type: <input type="checkbox"/> FM <input type="checkbox"/> PM		
Measurement reference amplitude _____		
<b>Spurious Signals</b>		
Frequency	Amplitude	Effective Peak Deviation

#### 4.19. TEST: Pre-detection Carrier Output

4.19.1 Purpose. This test measures the amplitude, frequency stability, and accuracy of the receiver pre-detection carrier output. Output instability and frequency errors could be caused by problems in any of the receiver local oscillators.

4.19.2 Test Equipment. An RF signal generator, microwave counter, counter, true rms voltmeter, power splitter, and wave analyzer (optional).

4.19.3 Test Method. This test measures the frequency and amplitude of the pre-detection output with a strong, unmodulated RF input signal. This test is suitable for manual or computer controlled testing. The pre-detection down converter may be in the receiver, in a diversity combiner, or in an external accessory housing.

4.19.4 Setup. Connect the test equipment as shown in [Figure 4-21](#).

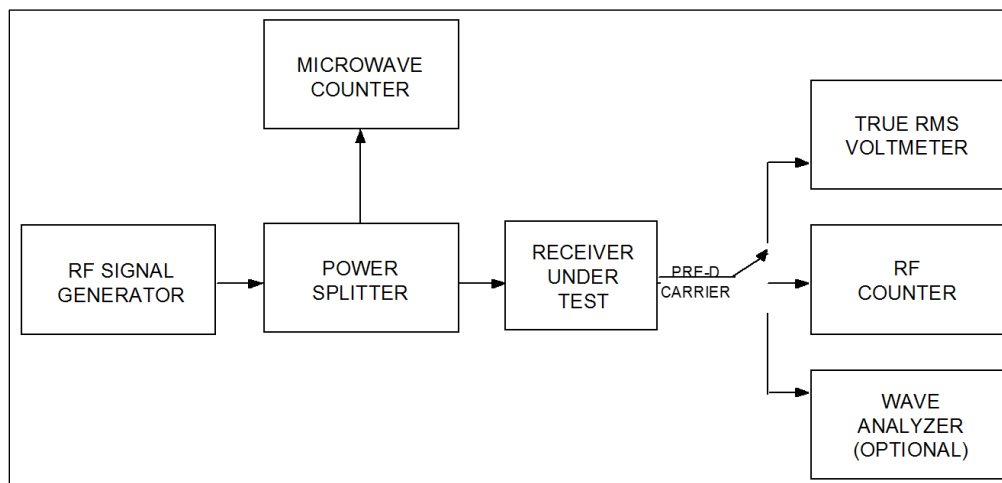

Figure 4-21. Receiver Pre-detection Carrier Output

4.19.5 Conditions. The RF signal generator must be stabilized before the test is started. The receiver should be on for the specified warm-up time before the start of the test. Set the RF signal generator frequency to the center frequency of the receiver under test. Set the RF signal generator output power to  $-50$  dBm.

#### 4.19.6 Procedure

1. Select a pre-detection carrier frequency. Measure the amplitude and frequency of the pre-detection output. Record these values on Data Sheet 4-19. The frequency at the receiver input shall also be counted and recorded on Data Sheet 4-19.
2. Repeat step 1 at 5-minute intervals over a 2-hour time interval. The interval between measurements and the total test time can be varied at the discretion of the test personnel.
3. This procedure can be repeated for other pre-detection carriers as desired.

4.19.7 Data Reduction. Record the maximum and minimum frequencies and amplitudes measured. Calculate and record the maximum frequency error (measured frequency – selected frequency).

Data Sheet 4-19.    Telemetry Receivers			
<b>Test 4.19</b>	<b>Pre-detection carrier output</b>		
<b>Manufacturer:</b> _____		<b>Model:</b> _____	
<b>Serial No:</b> _____		<b>Center frequency:</b> _____ <b>MHz</b>	
<b>IF BW:</b> _____ <b>kHz</b>	<b>Video BW:</b> _____ <b>kHz</b>		
Final LO mode: _____ XTAL: _____ VFO: _____ AFC/APC			
Test personnel: _____ Date: _____ Location: _____			
Pre-detection carrier frequency: _____ <b>kHz</b>			
Receiver Input		Pre-detection Output	
<b>Time</b>	<b>Frequency</b>	<b>Frequency</b>	<b>Amplitude</b>
Maximum frequency: _____ <b>kHz</b>			
Minimum frequency: _____ <b>kHz</b>			
Maximum frequency error: _____ <b>kHz</b>			
Maximum amplitude: _____ <b>volts rms</b>			
Minimum amplitude _____ <b>volts rms</b>			



#### 4.20. TEST: FM Receiver DC Linearity and Deviation Sensitivity

4.20.1 **Purpose.** This test measures the dc linearity and deviation sensitivity of the demodulator and video amplifier of a dc coupled FM TM receiver. This test method is well suited to computer controlled testing.

4.20.2 **Test Equipment.** An RF frequency synthesizer or RF generator, microwave counter, dc voltmeter, oscilloscope, and power splitter.

4.20.3 **Test Method.** The RF input frequency is varied in discrete steps and the video output voltage is measured for each input frequency. A best-fit line is calculated. The slope of this line is the deviation sensitivity.

4.20.4 **Setup.** Connect the test equipment as shown in [Figure 4-22](#). The oscilloscope should be used to make sure the video output does not have excessive noise or glitches.

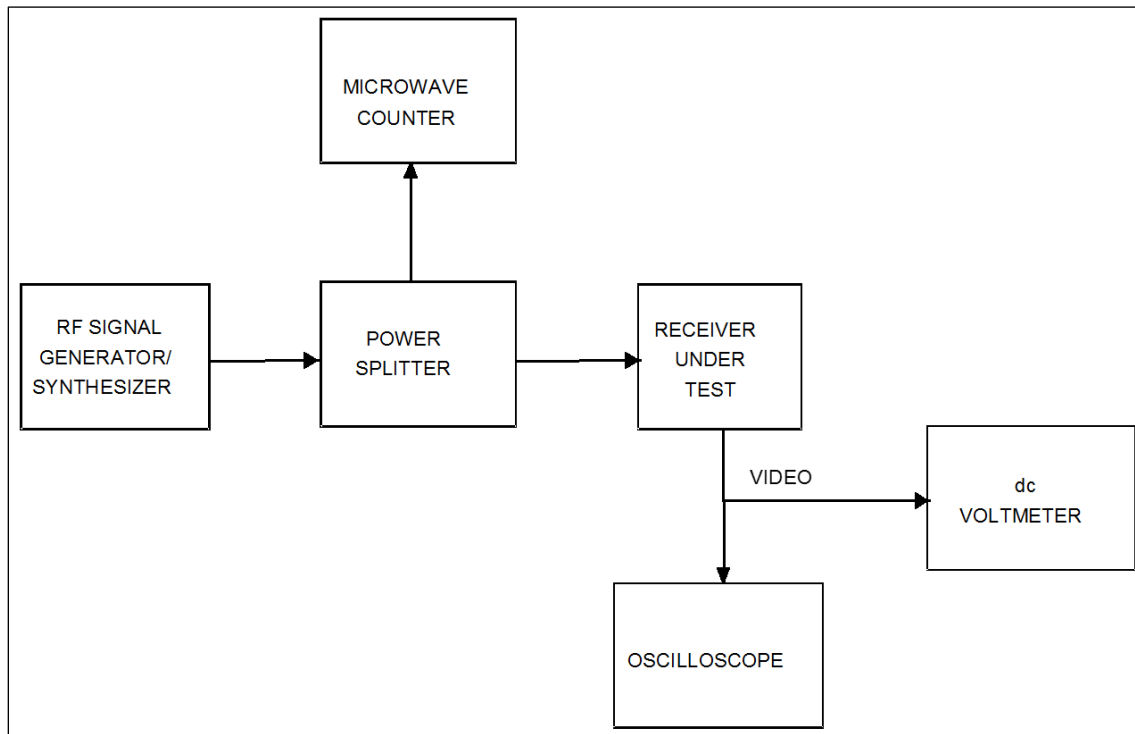

Figure 4-22. FM Receiver dc Linearity and Deviation Sensitivity

#### 4.20.5 Conditions

1. Set the TM receiver center frequency and video output filter as desired. Set the receiver local oscillators to crystal mode if possible. Automatic frequency control (AFC) mode is not acceptable.
2. Set the receiver final IF filter bandwidth to at least two times the peak deviation to be used in the test.
3. Set the generator RF output power to approximately  $-30$  dBm. This power level will produce a high SNR in the receiver under test.
4. Terminate the receiver video output with the proper impedance (typically 75 ohms).

5. Verify that the receiver video output is dc coupled. This test will not work with an ac-coupled video output.

#### 4.20.6 Procedure

1. Set the RF frequency to the center frequency of the receiver under test. Adjust the video output voltage to approximately 0 V.
2. Increase the RF frequency by an amount equal to the peak deviation to be used in this test. Verify that the receiver video output is not limited by increasing the RF frequency slightly. The video output should change accordingly.
3. This test may be performed with any number of equally spaced frequencies that is desired. Commonly used numbers of points are 5, 11, 21, and 41. Select the number of points and call it N. The frequency step size will be:

$$\frac{\text{peak deviation}}{\frac{N-1}{2}} \quad (\text{Eq. 4-12})$$

Frequency step sizes for several values of N are listed next (f = peak deviation).

<u>N</u>	<u>Frequency Step Size</u>
5	$\Delta f/2$
11	$\Delta f/5$
21	$\Delta f/10$
41	$\Delta f/20$

The smaller values of N should be used for a quick check of linearity while the larger values of N provide a better characterization of the linearity.

4. Set the RF frequency to a frequency equal to the receiver center frequency minus the desired peak deviation. Measure the receiver video output using the dc voltmeter. Record this value on Data Sheet 4-20 along with the measured RF input frequency.
5. Increase the RF frequency by one step:

$$\left[ \frac{\text{peak deviation}}{\frac{N-1}{2}} \right]$$

Measure and record the video output dc voltage and RF input frequency on Data Sheet 4-20.

6. Repeat the previous step until the RF frequency is equal to the receiver center frequency plus the desired peak deviation.

4.20.7 Data Reduction. The data reduction consists of calculating the best-fit straight line using the least squares method. This line is of the form

$$V = a + bf \quad (\text{Eq. 4-13})$$

Where:

V = measured output dc voltage (volts)

a = calculated video output offset

b = calculated deviation sensitivity (volts/kHz)

f = (measured input RF frequency – receiver center frequency) (kHz)

The coefficients a and b can be obtained from the following equations:

$$b = \frac{N(\sum_{i=1}^N f_i v_i) - (\sum_{i=1}^N v_i)(\sum_{i=1}^N f_i)}{N(\sum_{i=1}^N f_i^2) - (\sum_{i=1}^N f_i)(\sum_{i=1}^N f_i)} \quad (\text{Eq. 4-14})$$

And

$$a = \frac{(\sum_{i=1}^N v_i - b \sum_{i=1}^N f_i)}{N} \quad (\text{Eq. 4-15})$$

The worst-case deviation ( $E_{\max}$ ) from the best-fit straight line can be calculated using the following equation:

$$E_{\max} = \text{Maximum } (|V_i - a - b f_i|) \quad (\text{Eq. 4-16})$$

<b>Data Sheet 4-20. Telemetry Receivers</b>			
<b>Test 4.20</b>	<b>FM receiver dc linearity and deviation sensitivity</b>		
<b>Manufacturer:</b>		<b>Model:</b>	
<b>Serial No:</b>		<b>Center frequency:</b>	<b>MHz</b>
<b>IF BW:</b>	<b>kHz</b>	<b>Video BW:</b>	<b>kHz</b>
Final LO mode: _____ XTAL: _____ VFO: _____ AFC/APC			
Test personnel: _____ Date: _____ Location: _____			
RF Input Frequency (kHz)		Video Output (volts dc)	
_____		_____	
_____		_____	
_____		_____	
<div style="display: flex; justify-content: space-around;"> <span>a = _____ volts</span> <span>b = _____ Volts/kHz</span> <span><math>E_{max}</math> = _____ volts</span> </div>			

#### 4.21. TEST: Receiver Phase Noise

4.21.1 Purpose. This test verifies that the single-sideband phase noise of the receiver meets the specification. Excess phase noise can increase BER at a given  $E_b/N_0$  and degrade demodulator synchronization performance. This test assumes that a spectrum analyzer is the only appropriate measurement device available and therefore is limited to frequency offsets greater than 100 Hz. Measurements at lower frequency offsets tend to be very time consuming. Measurements closer to the carrier frequency can be made with very high quality spectrum analyzers exhibiting low internal phase noise and reliable 1-Hz or 3-Hz RBW settings. Specialized phase noise test sets are always the best choice especially if measurements must be made at frequency offsets below 100 Hz. The frequency range that has been observed to cause the most problems in current receiver designs is 1 to 20 kHz.

4.21.2 Test Equipment. RF generator with phase noise sidebands at least 10 dB lower than specified phase noise of system to be measured, spectrum analyzer with 10-Hz RBW (option: phase noise test set).

4.21.3 Setup. Connect test equipment as shown on [Figure 4-23](#). If a phase noise test set is available, connect the equipment and conduct the test in accordance with the manufacturer's instructions.

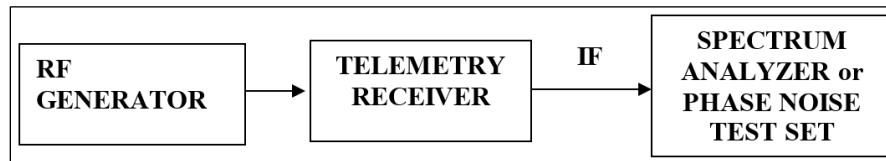

Figure 4-23. Test Setup for Receiver Phase Noise Test

4.21.4 Conditions. Use test conditions described in [Table 4-1](#).

#### 4.21.5 Procedure

1. Connect the RF generator output to the receiver's RF input and the spectrum analyzer to the receiver's linear IF output. Set the RF generator and receiver frequencies to the same value. Set the RF generator output level to provide a strong signal to the receiver (−30 dBm would usually be a reasonable value).
2. If the spectrum analyzer has a phase noise measurement mode, follow the manufacturer's instructions for this test. Otherwise, set the spectrum analyzer center frequency to the receiver final IF output center frequency. Set the span to 200 kHz with continuous sweep. Set the reference level such that the peak of the signal is near the top of the display. Set the center frequency such that the signal is 10 to 20 percent of full scale from the left edge of the display. Set the RBW to 1 kHz and VBW to 1 kHz. Average the spectrum over 100 sweeps. Record the maximum signal level on Data Sheet 4-21 (0-dBc level). If the analyzer has a power per 1-Hz measurement mode (sometimes referred to as "noise" mode), set the analyzer to that mode. Otherwise, correct for RBW and detector error by subtracting 27.5 dB in the signal processing step (−30 dB for conversion from 1-kHz to 1-Hz bandwidth +2.5 dB for typical spectrum analyzer detector error with noise-like signal, 2.5 dB is the approximate correction value for several common spectrum analyzers including the HP8566B but check your manual for the correct value for the spectrum analyzer used in the test). Use Data Sheet

4-21 to record power levels at frequency offsets of +10 kHz, +20 kHz, +50 kHz, and +100 kHz from the maximum signal (one can use peak search and delta marker functions to simplify the process). Record the frequency and level of any discrete components larger than -45 dB relative to the carrier (dBc) and any abnormally large continuous components. The results are only valid if the measured levels are at least 6 dB above the spectrum analyzer noise floor.

3. Set the spectrum analyzer center frequency to the receiver IF output center frequency. Set the span to 10 kHz with continuous sweep. Set the reference level such that the peak of the signal is near the top of the display and set the center frequency such that the maximum signal is 10 to 20 percent of full scale from the left edge of the display. Set the RBW to 100 Hz and VBW to 100 Hz. Average the spectrum over 100 sweeps. Record the maximum signal level on Data Sheet 4-21 (0-dBc level). If the analyzer has a power per 1-Hz measurement mode, set the analyzer to that mode. Otherwise, correct the readings by subtracting 17.5 dB in the signal processing step. Use Data Sheet 4-21 to record the power levels at frequency offsets of +1 kHz, +2 kHz, and +5 kHz from the maximum signal. Record the frequency and level of any discrete components larger than -45 dBc and any abnormally large continuous components.
4. (*optional test because of long time duration*) Set the spectrum analyzer center frequency to the receiver IF output center frequency. Set the span to 2 kHz and continuous sweep. Set the reference level such that the maximum value of the signal is at the top of the display and set the center frequency such that the maximum signal is 10 to 20 percent of full scale from the left edge of the display. Set the RBW to 10 Hz and VBW to 10 Hz. Average the spectrum over 100 sweeps (this process will take nearly 1 hour). Record the maximum signal level on Data Sheet 4-21 (0-dBc level). If the analyzer has a power per 1-Hz measurement mode, set the analyzer to that mode. Otherwise, correct the readings by subtracting 7.5 dB in the signal processing step. Use Data Sheet 4-21 to record the power levels at frequency offsets of +100 Hz, +200 Hz, and +500 Hz from the maximum signal. Record the frequency and level of any discrete components larger than -45 dBc and any abnormally large continuous components.

4.21.6 Data Reduction. Calculate phase noise by subtracting the main signal level from the measured noise level (not needed if delta markers were used to measure levels). If the spectrum analyzer does not have a power per Hz mode, correct for RBW and detector errors by subtracting 27.5, 17.5, or 7.5 dB as appropriate (see above).

<b>Data Sheet 4-21. Telemetry Receivers</b>			
<b>Test 4.21</b>		<b>Receiver phase noise test</b>	
<b>Manufacturer:</b>		<b>Model:</b>	
<b>Serial No:</b>		<b>Center frequency:</b> _____ <b>MHz</b>	
Test personnel: _____ Date: _____ Location: _____			
Frequency (offset from carrier) (kHz)	Maximum Signal (Carrier) Power (dBm)	Measured Power Level (dBm)	Phase Noise (dBc/Hz)
0.1			
0.2			
0.5			
1			
2			
5			
10			
20			
50			
100			

## 4.22. TEST: Receiver Adjacent Channel Interference

4.22.1 Purpose. This test measures the effect on bit error probability (BEP) of signals in adjacent frequency slots. The results will be a function of modulation methods, receiver filter characteristics, bit rates, relative power levels, frequency spacing, and demodulator characteristics.

4.22.2 Test Equipment. Spectrum analyzer, BERT, attenuators, signal sources, noise source, power splitters, power meter, and a bit synchronizer if the receiver/demodulator does not include one (a specialized adjacent-channel interference test set can be used if one is available).

4.22.3 Setup. Connect test equipment as shown in [Figure 4-24](#).

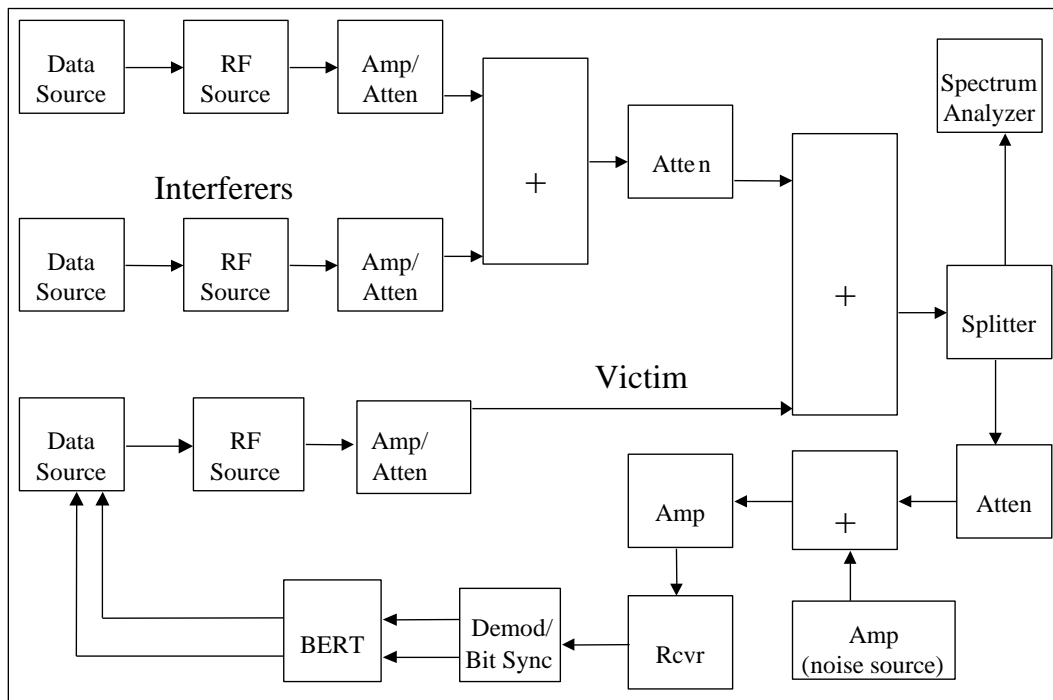

Figure 4-24. Test Setup for Adjacent Channel Interference Test

4.22.4 Conditions. This test can be performed using various modulation types as the interferers. All filtering and deviations should be the same as would typically be used in TM operations. The test can also be performed with only one interferer or with two interferers (one above and one below the victim signal). This test can be performed with actual TM transmitters or with appropriate laboratory signal generators. The laboratory generators should be passed through an amplifier of the same type as what will be used in the actual transmitters (an amplifier operating in its non-linear range can be used instead of a Class C amplifier if a Class C amplifier is not available). If the purpose of the test is to evaluate performance during a test mission with a specific set of frequencies, bit rates, and modulation types, use these parameters for the test.

### 4.22.5 Procedure

1. Set the receiver and demodulator to the nominal values that would be used to receive the victim signal. Set the BERT to generate the desired bit rate with a pseudo noise sequence length of at least  $2^{11}-1$  bits. Use this BERT as the input to an RF source of the desired type



(this signal will be the center signal and called the victim). The modulator output will typically need to be non-linearly amplified. Similarly, modulate the other two RF sources with independent pseudo noise sequences at the same bit rate and non-linearly amplify (the purpose of the non-linear amplification is to emulate a typical TM transmitter) the outputs. Set the frequencies of these signals to frequencies spaced the desired amounts (for example, for NRZ-L PCM/FM the desired spacing would be in the range of 2 to 2.5 times the bit rate if all signals were at the same bit rate) above and below the frequency of the victim signal.

2. Apply maximum attenuation to the two interferers to effectively remove them from the output (at least 30 dB below desired signal power). Set the attenuation of the victim such that the level at the receiver input is typical of what would be expected in actual use and vary the noise source level to produce a BEP of  $10^{-5}$ . Increase the level of the victim signal by 1 dB.
3. Use the spectrum analyzer (or alternatively a power meter) to set the relative powers of the signals. A typical starting point is to have the two interfering signals 20 dB larger than the victim signal. Vary the attenuator that is common to the two interferers until the BEP is again  $10^{-5}$ . Measure the power levels of the victim and interferers at the receiver input and record on Data Sheet 4.22.
4. Repeat steps 1 through 3 for various modulation types, bit rates, center frequencies, and frequency separations, as desired.

4.22.6 Data Reduction. Subtract the victim power level from the interferer power level and record on Data Sheet 4.22.

<b>Data Sheet 4-22. Telemetry Receivers</b>	
<b>Test 4.22</b>	<b>Adjacent channel interference</b>
Manufacturer:	Model:
Serial No.:	
Test Personnel:	Date:
Receiver IF Bandwidth _____ MHz	
Victim: Frequency _____ MHz	Bit rate _____ Mbps
Peak deviation _____	Filter BW _____ MHz
Power _____ dBm	
Interferer 1: Frequency _____ MHz	
Peak deviation _____	Bit rate _____ Mbps
Filter BW _____ MHz	Modulation type _____
Power _____ dBm	
Interferer 2: Frequency _____ MHz	
Peak deviation _____	Bit rate _____ Mbps
Filter BW _____ MHz	Modulation type _____
Power _____ dBm	
<b>Power level difference between Victim and Interferers _____ dB</b>	
Receiver IF Bandwidth _____ MHz	
Victim: Frequency _____ MHz	Bit rate _____ Mbps
Peak deviation _____	Filter BW _____ MHz
Power _____ dBm	
Interferer 1: Frequency _____ MHz	
Peak deviation _____	Bit rate _____ Mbps
Filter BW _____ MHz	Modulation type _____
Power _____ dBm	
Interferer 2: Frequency _____ MHz	
Peak deviation _____	Bit rate _____ Mbps
Filter BW _____ MHz	Modulation type _____
Power _____ dBm	
<b>Power level difference between Victim and Interferers _____ dB</b>	
Receiver IF Bandwidth _____ MHz	
Victim: Frequency _____ MHz	Bit rate _____ Mbps
Peak deviation _____	Filter BW _____ MHz
Power _____ dBm	
Interferer : 1 Frequency _____ MHz	
Peak deviation _____	Bit rate _____ Mbps
Filter BW _____ MHz	Modulation type _____
Power _____ dBm	
Interferer 2: Frequency _____ MHz	
Peak deviation _____	Bit rate _____ Mbps
Filter BW _____ MHz	Modulation type _____
Power _____ dBm	
<b>Power level difference between Victim and Interferers _____ dB</b>	

## CHAPTER 5

### Test Procedures for Diversity Combiners

#### 5. General

These tests measure the performance of pre-detection and post-detection diversity combiners under static and dynamic operating conditions. The static tests include operation with equal and unequal SNRs at the combiner signal inputs. The dynamic tests include operation with equal and unequal average SNRs at the combiner inputs, in-phase and out-of-phase fading, and periodic and random fading. These tests are designed to make the results independent of other components of the system to the maximum extent possible. The criterion for evaluation of combiner performance is measurement of BEP improvement (or degradation) when signals are combined as compared with single-channel operation. The BEP is defined as the ratio of bit errors to the total number of bits transmitted in a given time interval. (For typical results of various tests, see Ashley and Hill.<sup>5</sup>)

The fading tests with sinusoidal modulation of the phase shifters simulate the signal level variations of specular reflection such as off water and land and the signal level variations of transmitting antenna nulls. The fading tests with Gaussian noise modulation of the phase shifters simulate the signal level variations that occur when the RF signal passes through the flame plasma of a missile.

[Table 5-1](#) lists the types of tests and their test and paragraph number.

<b>Table 5-1. Test Matrix for Diversity Combiners</b>	
<b>Test Number</b>	<b>Test Description</b>
<a href="#">5.1</a>	Diversity combiner static evaluation with equal RF signal strengths
<a href="#">5.2</a>	Diversity combiner static evaluation with unequal RF signal strengths
<a href="#">5.3</a>	Diversity combiner dynamic evaluation with in-phase fading and equal RF signal strengths
<a href="#">5.4</a>	Diversity combiner dynamic evaluation with periodic in-phase fading and unequal RF signal strengths
<a href="#">5.5</a>	Diversity combiner dynamic evaluation with periodic out-of-phase fading and equal RF signal strengths
<a href="#">5.6</a>	Diversity combiner dynamic evaluation with periodic out-of-phase fading and unequal RF signal strengths
<a href="#">5.7</a>	Diversity combiner break frequency test
<a href="#">5.8</a>	Diversity combiner evaluation with random fading
<a href="#">5.9</a>	Pre-detection combiner band pass frequency response using phase-modulated signal
<a href="#">5.10</a>	Pre-detection combiner band pass frequency response using unmodulated signal
<a href="#">5.11</a>	Combiner data frequency response test
<a href="#">5.12</a>	Combiner pre-detection carrier output

<sup>5</sup> Ashley, C. G. and E. R. Hill. Diversity Combiner Characterization Preliminary Test Report. TP-72-13. Pacific Missile Test Center, Point Mugu, California, 12 April 1972.

### 5.1. TEST: Diversity Combiner Static Evaluation with Equal RF Signal Strengths

5.1.1 **Purpose.** This test evaluates the static performance characteristics of a diversity combiner as a component with the two combiner channels weighted equally. This test is the least demanding of diversity combiner tests. If the diversity combiner has difficulty passing this test, it will not likely pass any other tests and may do more harm than good if used in a TM receive system.

5.1.2 **Test Equipment.** An RF signal generator, PCM BERT, PCM bit synchronizer, RF attenuators, dual-channel TM receiver, RF power meter, dc power supply, dc voltmeter, low-pass filter, and power splitter.

#### 5.1.3 Setup

1. Connect the test equipment as shown in [Figure 5-1](#).

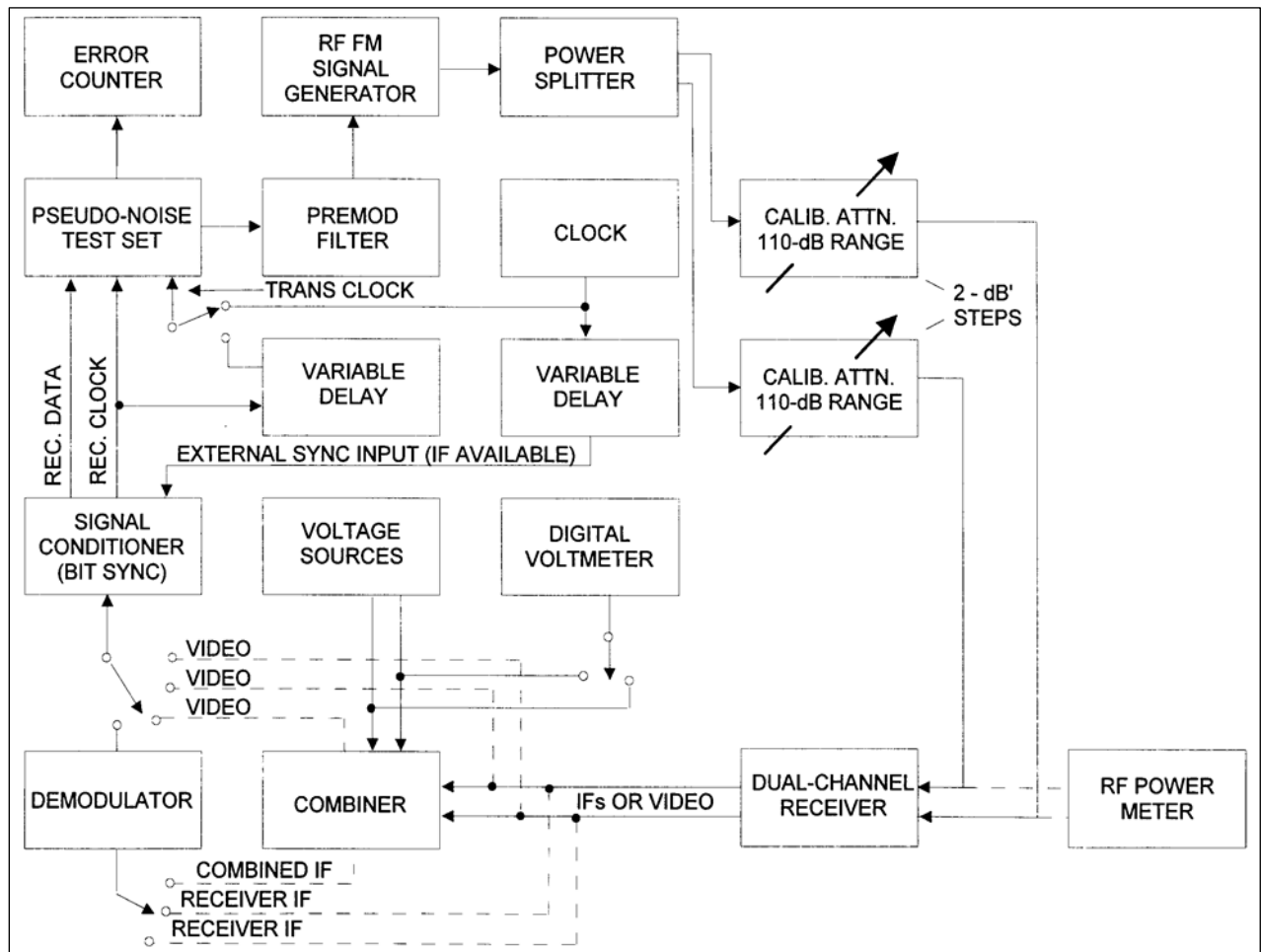



Figure 5-1. Static Evaluation Test Setup for Diversity Signal Combiner

2. To make the test results independent of characteristics of components in the test setup (other than the combiner under test) to the maximum extent possible, it is desirable to have a common clock signal (hardware synchronizer) to drive both the pseudo-noise test set and the

bit synchronizer. The preferred method is to use an external clock source. A variable delay is needed between the clock and the external synchronizer input to the bit synchronizer to ensure that the data bit stream is sampled at the correct time interval. The reason for adjusting the variable delay is to produce the lowest BEP. If the bit synchronizer is not equipped to accept an external synchronizing signal, hardware synchronization may be simulated as shown in [Figure 5-1](#) by using a properly delayed clock signal from the bit synchronizer to drive the test set. The variable delay is needed in this interconnection to cause the clock signals to occur at the correct rate. The clock rate is a function of the delay setting because the test setup comprises a closed loop and the phase lock loop in the bit synchronizer locks up at the specific frequency for each delay. The delay setting is correct when the clock rate matches the rate selected by the front panel controls on the bit synchronizer.

 <p><b>NOTE</b></p>	<p>Two single-channel receivers can be used to conduct the test rather than the dual-channel receiver indicated in the test setup. If single-channel receivers are used for pre-detection combining, it is strongly recommended that the receivers be interconnected so that common (both first and second) local oscillators are used. For post-detection combining, common local oscillators are not a requirement.</p>
--	---

5.1.4 Conditions. Tests are conducted by using simulated PCM data formats. Select test conditions that correspond to the conditions under which the combiner will be used.

5.1.4.1 Receiver Tuning. Tune the receiver so that the modulated carrier is in the center of the IF passband. Improper tuning can have significant degrading effects on test results. If unusual or inconsistent data is noted during testing, check the tuning.

5.1.4.2 Test Equipment Settings

Signal generator frequency:	Receiver band center frequency
Receiver LOs (first and second):	Common (pre-detection combining)
Receiver AGC:	ON (fastest time constant)
PN pattern length:	2047 bits

5.1.4.3 Single-Channel BEP Reference Measurements. A method is needed to make single-channel BEP measurements that can be compared with BEP measurements for the combined signals. The bypass method of measurement is recommended provided an external demodulator is available. If an external demodulator is not available, use the alternate method for AGC weighted combiners described in [Subsection 5.1.4.3.2](#).

*5.1.4.3.1. Bypass Method.* In the pre-detection mode, bypass the combiner and connect the receiver IF signals, one at a time, to an external demodulator. In the post-detection mode, bypass the combiner and connect the receiver video outputs, one at a time, directly to the signal conditioner (bit synchronizer). Connect the external demodulator output to the signal conditioner (bit synchronizer). An external demodulator is needed because the same demodulator is used for both single-channel measurements and combined signal measurements and because the demodulator in the receiver is not accessible when combined signal measurements are being made.

*5.1.4.3.2. Alternate Method.* Disconnect both of the receiver AGC input voltages at the combiner. Substitute an external dc voltage source for one of the AGC voltages and leave the other AGC input to the combiner disconnected. The external dc voltage should be adjusted to a

level that corresponds to a strong RF signal for the channel under test. In addition, it may be necessary to disconnect the IF input signal that corresponds to the AGC input that was disconnected.

#### 5.1.5 Procedure

1. Record measured data on Data Sheet 5-1.
2. Adjust the RF input levels to receiver channels 1 and 2 for approximately  $-60$  dBm at the receiver (calibrated attenuators set to 40 dB). Adjust the combiner according to the manufacturer's instructions.
3. Consult the single-channel BEP reference measurements described in Subsection [5.1.4.3](#) and select the method best suited for the combiner under test. Using the selected single-channel BEP measurement method, adjust the calibrated attenuator to reduce the receiver RF input level to channel 1 until the BEP is approximately  $1.5 \cdot 10^{-2}$ . Similarly, adjust the receiver RF input level to channel 2 until the BEP measured by the error counter is approximately  $1.5 \cdot 10^{-2}$ .

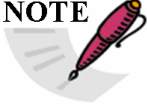
 <b>NOTE</b>	The RF input levels to channels 1 and 2 should not differ by more than 3 dB. If there is a difference, it must be maintained throughout the test to obtain valid data. If the difference is greater than 3 dB, recheck the setup and the receiver tuning adjustments. If the difference is still greater than 3 dB, some attention should be given to repairing or realigning the receiver. The combiner must be aligned so that the channels are weighted equally when the data quality of the channel is the same.
---	--

4. Determine the appropriate artificial AGC voltages. In preparing to measure the BEP that results from signal combining, appropriate artificial AGC voltages must be supplied to the combiner. Next is an example of how artificial AGC voltages are selected. Assume that the receiver in the test setup develops an AGC of  $-2$  V when the RF input to the receiver is  $-90$  dBm. Also assume that the receiver AGC slope is 50 mV/dB. Thus, the artificial AGC voltage to the combiner should be  $-2$  V when the RF input to the receiver is  $-90$  dBm,  $-1.90$  V when the RF input to the receiver is  $-92$  dBm,  $-1.80$  V when the RF input to the receiver is  $-94$  dBm.
5. Adjust the RF input to the receiver and the AGC voltage to the combiner to produce a single-channel BEP reading within the range of  $1 \cdot 10^{-5}$  to  $1 \cdot 10^{-4}$ . (This signal level represents a proper signal level with a conveniently measured number of bit errors and serves as a starting point for the measurements following.) Measure and record the BEP for each single-channel signal and for the combined channel signal on Data Sheet 5-1. Also record the RF input levels for channels 1 and 2.
6. Decrease the RF input levels to the receiver in 2-dB steps and at the same time decrease the AGC voltage to values corresponding to 2 dB step changes in RF input levels (see step 4). Measure and record on Data Sheet 5-1 the single-channel BEP, combined channel BEP, and the RF input levels until a single-channel BEP range of approximately  $1 \cdot 10^{-5}$  to  $2 \cdot 10^{-1}$  has been covered.

5.1.6 Data Reduction. The BEP at the demodulated output of a pre-detection combiner at a given RF power level should be less than the BEPs of the single channels at a 2 dB stronger RF

power level. If this condition is not true, the combiner and receiver alignment and interconnections should be checked. If everything is correct, the combiner is not working properly. Post-detection combiner performance is a function of modulation but should not be worse than the best single channel.

<b>Data Sheet 5-1. Diversity Combiners</b>					
<b>Test 5.1</b>		<b>Static, equal RF signal strength</b>			
<b>Manufacturer:</b>		<b>Model:</b>		<b>Serial No.:</b>	
<b>Test Personnel:</b>				<b>Date:</b>	
<b>Mode: Pre-D:</b>				<b>Post-D:</b>	
<b>Single channel measurement technique used:</b>					
<b>AGC</b>	<b>RF Input Level</b>		<b>Bit Error Probability</b>		
Volts	Channel 1 (dBm)	Channel 2 (dBm)	Channel 1	Channel 2	Combined



## 5.2. TEST: Diversity Combiner Static Evaluation with Unequal RF Signal Strengths

5.2.1 Purpose. This test evaluates the static performance characteristics of a diversity combiner with unequal RF signal strengths.

5.2.2 Test Equipment. Refer to Subsection [5.1.2](#).

5.2.3 Setup. Connect the test equipment as described in Subsection [5.1.3](#).

5.2.4 Conditions. Use the test conditions described in Subsection [5.1.4](#).

5.2.5 Procedure

1. Record measured data on Data Sheets 5-2(1) and 5-2(2).
2. Measure the single-channel BEP for both channels and the combined signal BEP while the RF input level is held constant at a selected level in one channel and varied over a selected range in the other channel. Repeat these measurements for a total of three selected constant RF input levels. When choosing the constant input levels, examine the data recorded on Data Sheet 5-2(1) and select the three RF input levels and AGC voltages that resulted in single-channel BEP readings of approximately  $1 \cdot 10^{-5}$ ,  $1.5 \cdot 10^{-2}$ , and  $2 \cdot 10^{-1}$ . These levels will be identified as X, Y, and Z. Data sheets 5-2(1) and 5-2(2) can be used for measurements at levels X, Y, and Z interchangeably by simply deleting two of the letters and entering the selected RF level and AGC voltage on the data sheet. The ranges of RF levels and AGC voltages for the variable channel are selected by again examining Data Sheet 5-2(1). The detailed procedures are described next.
3. While holding the channel 1-RF input and AGC voltage constant at values corresponding to level X, change the channel 2-RF input level in 2-dB steps over the range shown on Data Sheet 5-2(1) for this test and change the AGC voltage for each RF step in increments required by the AGC slope of the receiver in the test setup (see Subsection [5.1.5](#) step 4 for an example). Following steps 2 through 6 in Subsection [5.1.5](#), measure channel 1 BEP, channel 2 BEP, the combined BEP, and record the measurements on Data Sheet 5-2(1). Repeat these measurements while holding the channel 1-RF input and AGC voltage at constant values corresponding to levels Y and Z. For each of the selected channel-1 RF input levels (X, Y, or Z), the channel-1 BEP should remain constant and need not be measured each time a channel-2 measurement is made. The channel 1 BEP should be checked occasionally to make sure that the bit error change is not excessive (10 percent of the total bit errors or 20 bit errors, whichever is greater). If the bit error change is excessive, additional warm-up time may be required to allow the signal generator and the receiver to stabilize.
4. Repeat the measurement sequence described in step 3 with the channel 2-RF input and AGC voltage held constant at levels X, Y, and Z rather than channel 1. Record the data on Data Sheet 5-2(2).

5.2.6 Data Reduction. The BEP at the combiner output should be less than or equal to the BEP of the “best” channel. A 0.5-dB degradation, interpolated from data in Test [5.1](#), is allowable. If this condition is not true, the combiner and receiver alignment and interconnections should be checked. If everything is correct, the combiner is not working properly.

Data Sheet 5-2(1). Diversity Combiners								
Test 5.2		Static, unequal RF signal strength						
Manufacturer:			Model:		Serial No.:			
Test Personnel:					Date:			
Mode: Pre-D:					Post-D:			
Single channel measurement technique used:								
RF Input Level and AGC				Bit Error Probability				
Channel 1		Channel 2		Channel 1	Channel 2	Channel 3		
RF (dBm)	AGC (volts)	RF (dBm)	AGC (volts)					
		↑	↑					
		↓	↓	X, Y, Z				

Data Sheet 5-2(2). Diversity Combiners							
Test 5.2		Static, unequal RF signal strength					
Manufacturer:		Model:		Serial No.:			
Test Personnel:				Date:			
Mode: Pre-D:				Post-D:			
Single channel measurement technique used:							
RF Input Level and AGC				Bit Error Probability			
Channel 1		Channel 2		Channel 1	Channel 2	Combined	
RF (dBm)	AGC (volts)	RF (dBm)	AGC (volts)				
 X, Y, Z							

### 5.3. TEST: Diversity Combiner Dynamic Evaluation with In-Phase Fading and Equal RF Signal Strengths

5.3.1 **Purpose.** This test evaluates the dynamic performance characteristics of a diversity signal combiner as a component.

5.3.2 **Test Equipment.** An RF signal generator, dual-channel TM receiver, diversity signal simulator, PCM BERT, PCM bit synchronizer, RF power meter, and low pass filter.

5.3.3 **Setup.** Connect the test equipment as shown in [Figure 5-2](#) and [Figure 5-3](#). See Subsection [5.1.3](#) for additional setup information.

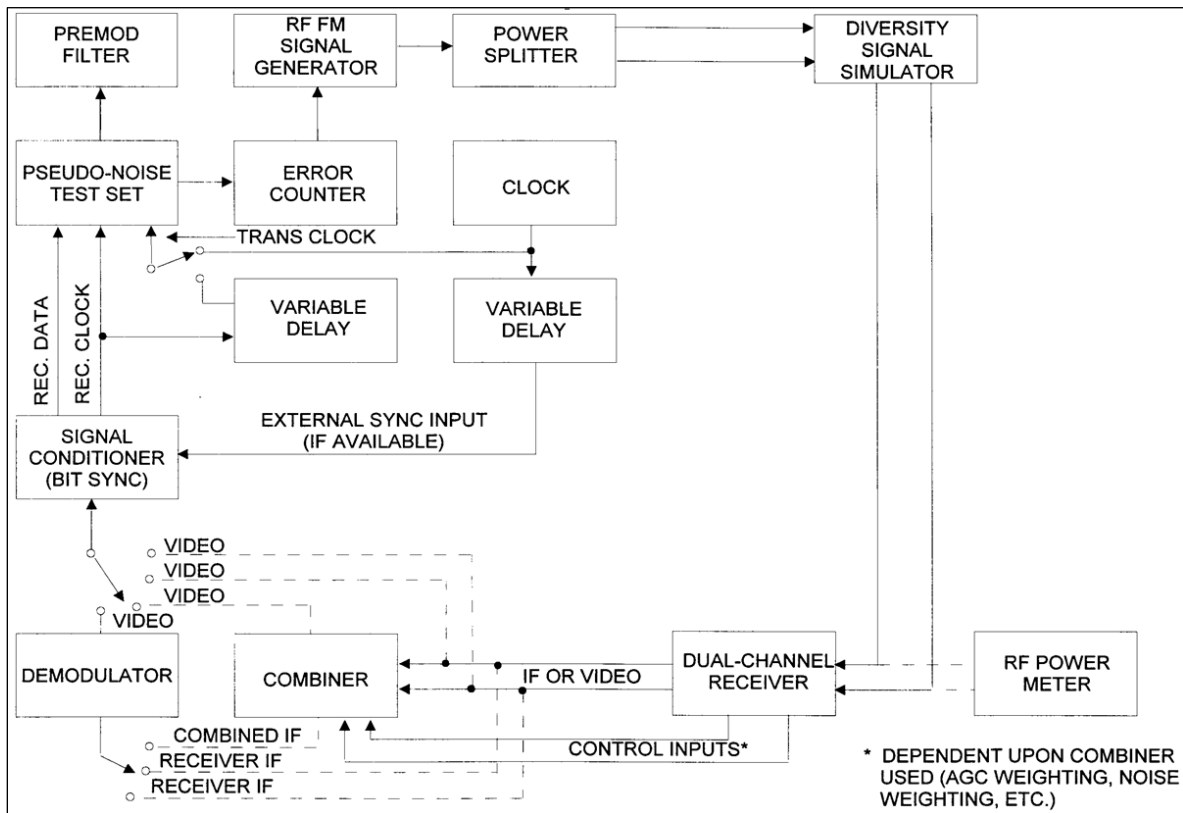

Figure 5-2. Dynamic Evaluation Test Setup for Diversity Signal Combiner

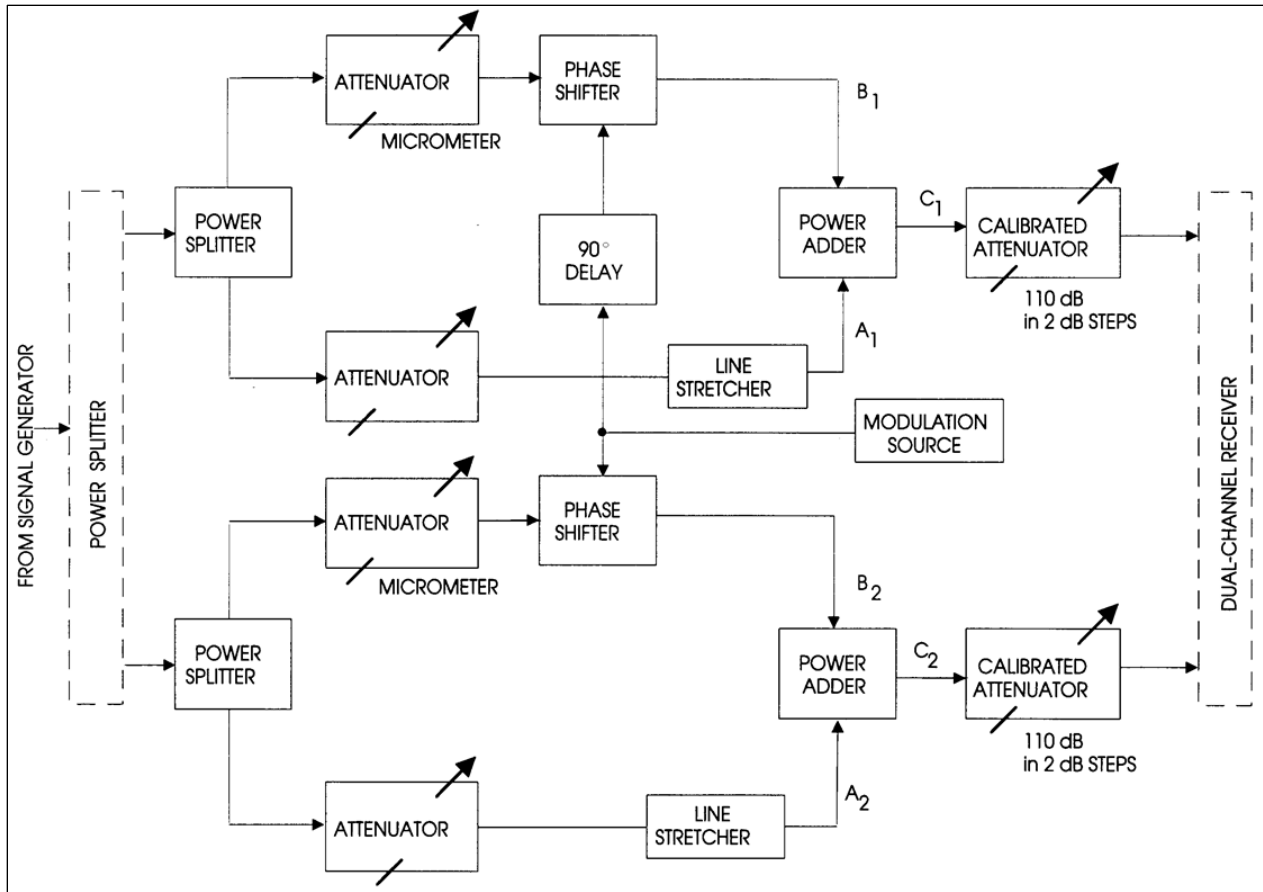



Figure 5-3. Diversity Signal Simulator

5.3.4 Conditions. Use the test conditions described in Subsection 5.1.4.

5.3.5 Procedure

1. Record data on Data Sheet 5-3.
2. Connect the power splitter outputs directly to the dual-channel receiver (see Figure 5-2 and Figure 5-3). Adjust the receiver RF input levels to channel 1 and channel 2 for approximately  $-60$  dBm at the receiver (calibrated attenuators set to 40 dB). Tune the receiver and adjust the combiner according to the manufacturer's instructions.
3. Reconnect the diversity simulator into the test setup and make the following adjustments to produce signal fades of 20 dB at a rate of 50 fades per second.

 <p><b>NOTE</b></p>	<p>Signal fades are produced by adjusting the simulator (see Figure 5-3) so that the signals at <math>A_1</math> and <math>B_1</math> have the proper relative amplitudes and a median phase angle between them of <math>180^\circ</math>. The same requirements apply to the signals at <math>A_2</math> and <math>B_2</math>.</p>
--	---

4. Select the fastest receiver AGC time constant and adjust the frequency of the phase shifter modulation source in the diversity simulator (Figure 5-3) to 25 Hz. (This setting will produce 50 fades per second.) The modulation waveform should be a sine wave. Connect one input of

a dual-channel oscilloscope to monitor channel 1 receiver AGC voltage. Connect the other input of the oscilloscope to monitor the phase shifter modulation waveform.



**NOTE** The modulation frequency should be low enough to allow the AGC to track the RF signal fades. If 25 Hz is too high, select a frequency where the product of the AGC time constant (in seconds) and the modulation frequency (in Hz) is equal to or less than 0.01. It should be noted also that phase shifters are normally deviated by a positive voltage only. Therefore, to deviate about a point such as the 180° phase difference between A<sub>1</sub> and B<sub>1</sub>, the modulation voltage must include a dc offset. The offset and the modulation voltage amplitude depend on the performance characteristics of the phase shifter and may vary from model to model.

- Remove the 90° delay that is shown in [Figure 5-3](#) between the modulation source and one of the phase shifters. Adjust the line stretcher in path A<sub>1</sub> until the oscilloscope display appears as shown in [Figure 5-4](#). Assuming that the receiver produces a negative going AGC voltage in response to increasing RF signal strength, the important aspect of the adjustment is to ensure that the two negative excursions of the AGC voltage are equal. Nonsymmetry in the horizontal axis reflects the nonlinearity of the phase shifter. This nonlinearity is not highly important unless nonlinearity exceeds a ratio of approximately 2:1, in which case the symmetry can be improved by decreasing the amplitude of the modulation voltage applied to the phase shifters. Next, adjust the micrometer attenuator in line B<sub>1</sub> until the AGC excursion indicates a 20-dB fade depth of the RF signal. It may also be necessary to adjust the attenuator in line A<sub>1</sub>. The AGC slope of the receiver must be known to calibrate the oscilloscope. The linear region of the AGC curve should be used in making the calibration.

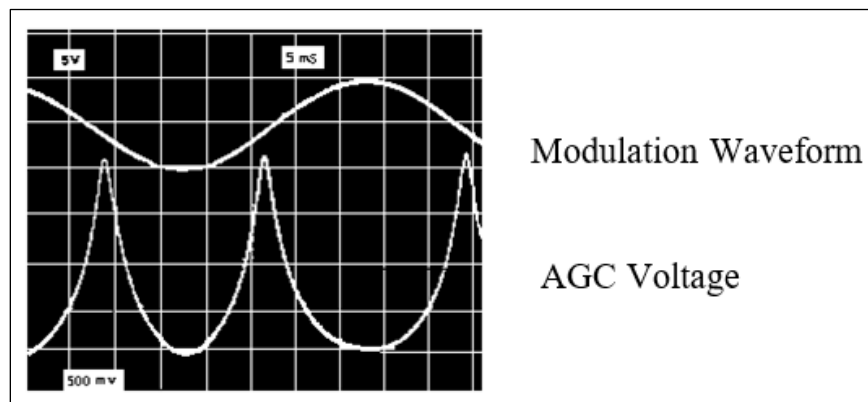

Figure 5-4. Phase-Shifter Modulation and Receiver-AGC Voltage



**NOTE** The line stretcher in path A<sub>1</sub> and the micrometer attenuator in path B<sub>1</sub> interact. Therefore, several adjustments of the line stretcher and the micrometer attenuator may be required to equalize the AGC voltage excursions and ensure that a 20-dB fade depth is produced.

- Repeat steps 4 and 5 to make the proper adjustments in lines A<sub>2</sub> and B<sub>2</sub> while observing the channel 2 receiver AGC voltage.
- Connect a dual-channel oscilloscope to the two receiver AGC voltages to observe that the signal fading occurs in phase. The 90° delay in the fade simulator is still removed. Consult the single-channel BEP measurement methods described in Subsection [5.1.4.3](#) and select the

method best suited for the combiner under test. Using the selected single-channel BEP measurement method, make the proper connections to measure the BEP of channel 1. Use the calibrated attenuator to adjust the receiver RF input signal level to channel 1 until the BEP is approximately  $1.5 \cdot 10^{-2}$ . (A BEP of  $1.5 \cdot 10^{-2}$  was selected because it represents enough errors for single-channel performance to be readily compared.) Measure and record the BEP and the RF input on Data Sheet 5-3. Repeat for channel 2.



**NOTE** The RF levels required in channels 1 and 2 to produce approximately  $1.5 \cdot 10^{-2}$  BEP should not differ more than 3 dB. If there is a difference, it must be maintained throughout the test to obtain valid data. When the difference is greater than 3 dB, recheck the setup and tuning adjustments. If the difference remains greater than 3 dB, attention should be given to repairing or realigning the receiver.

8. After the single-channel performance has been suitably equalized (within 3 dB), adjust the RF inputs to produce single-channel BEP readings in the range of approximately  $1 \cdot 10^{-5}$  to  $1 \cdot 10^{-4}$ . (This signal level represents a proper signal level with a conveniently measured number of bit errors.) Measure and record the BEP for each single channel and for the combined signal on Data Sheet 5-3. Also measure the RF input levels for channels 1 and 2.



**NOTE** Maintain the RF input level difference observed above.

9. Use the calibrated attenuators to decrease the RF input levels to the receiver in 2-dB steps. Measure and record on Data Sheet 5-3 the single-channel BEPs, the combined signal BEP, and the RF input levels until a single-channel BEP range of approximately  $1 \cdot 10^{-5}$  to  $2 \cdot 10^{-1}$  has been covered.

**5.3.6 Data Reduction.** The BEP at the demodulated output of a post-detection combiner at a given RF power should be less than the BEPs of the single channels at a 2-dB stronger RF power level. If this condition is not true, the combiner and receiver alignment and interconnections should be checked. If everything is correct, the combiner is not working properly. Post-detection combiner performance is a function of modulation but should not be worse than the best single channel.

<b>Data Sheet 5-3. Diversity Combiners</b>				
<b>Test 5.3</b>	<b>Dynamic, equal RF signal strength (in-phase fading)</b>			
<b>Manufacturer:</b>		<b>Model:</b>		<b>Serial No.:</b>
<b>Test Personnel:</b>				<b>Date:</b>
<b>Mode: Pre-D:</b>				<b>Post-D:</b>
<b>Single channel measurement technique used:</b>				
<b>RF Input Level</b>		<b>Bit Error Probability</b>		
Channel 1 (dBm)	Channel 2 (dBm)	Channel 1	Channel 2	Combined



## 5.4. TEST: Diversity Combiner Dynamic Evaluation with Periodic In-Phase Fading and Unequal RF Signal Strengths

5.4.1 Purpose. This test evaluates the dynamic performance of a diversity combiner with periodic in-phase fading and unequal RF signal strengths.

5.4.2 Test Equipment. Refer to Subsection [5.3.2](#).

5.4.3 Setup. Connect the test equipment as shown in [Figure 5-2](#) and [Figure 5-3](#). See Subsection [5.1.3](#) for additional setup information.

5.4.4 Conditions. Use the test conditions described in Subsection [5.1.4](#).



5.4.5 Procedure



1. Record measured data on Data Sheets 5-4(1) and 5-4(2).
2. Check or repeat steps 2 through 4 in Subsection [5.3.5](#).
3. Measure the single-channel BEP for both channels and the combined signal BEP while the average RF input level is held constant at a selected level in one channel and varied over a selected range in the other channel. Repeat these measurements for a total of three selected constant RF input levels. In choosing the constant RF input levels, examine the data recorded on Data Sheet 5-3 and select the three average RF input levels that resulted in single-channel BEP readings of approximately  $1 \cdot 10^{-5}$ ,  $1.5 \cdot 10^{-2}$ , and  $2 \cdot 10^{-1}$ . These levels will be identified as X, Y, and Z. Data sheets 5-4(1) and 5-4(2) can be used for measurements at levels X, Y, and Z interchangeably by simply deleting two of the letters and entering the selected average RF level on the data sheet. The ranges of RF levels for the variable channel are selected by again examining Data Sheet 5-3. The detailed procedures follow.
4. While holding the channel 1 average RF input constant at level X, vary the channel 2 average RF input level in 2-dB steps over the range shown on Data Sheet 5-3 for Test [5.3](#). Using these procedures, measure channel 1 BEP, channel 2 BEP, and the combined BEP. Repeat the measurement while holding the channel 1 average RF inputs constant at levels Y and Z. For each of the selected channel 1 RF input levels (X, Y, and Z), the channel 1 BEP should remain constant and need not be measured each time a channel 2 BEP measurement is made.

 <b>NOTE</b>	The channel 1 BEP should be checked occasionally to make sure that the drift is not excessive (10 percent of the total bit errors or 20 bit errors, whichever is greater). If the bit error change is excessive, additional warm-up time may be required to allow the signal generator and the receiver to stabilize.
---	---

5. Repeat the measurement sequence described in steps 3 and 4 with the channel 2 average RF input held constant at levels X, Y, and Z rather than channel 1. Record data on Data Sheet 5-4(2).

5.4.6 Data Reduction. The BEP at the combiner output should be less than or equal to the BEP of the “best” channel. A 0.5-dB degradation, interpolated from data in Test [5.3](#), is allowable. If this condition is not true, the combiner and receiver alignment and interconnections should be checked. If everything is correct, the combiner is not working properly.

<b>Data Sheet 5-4(1). Diversity Combiners</b>					
<b>Test 5.4</b>		<b>Dynamic, unequal RF signal strength (in-phase fading)</b>			
<b>Manufacturer:</b>		<b>Model:</b>		<b>Serial No.:</b>	
<b>Test Personnel:</b>				<b>Date:</b>	
<b>Mode: Pre-D:</b>				<b>Post-D:</b>	
<b>Single channel measurement technique used:</b>					
<b>RF Input Level</b>		<b>Bit Error Probability</b>			
Channel 1 RF (dBm)	Channel 2 RF (dBm)	Channel 1	Channel 2	Combined	
 X, Y, Z					
					

Data Sheet 5-4(2). Diversity Combiners				
Test 5.4		Dynamic, unequal RF signal strength (in-phase fading)		
Manufacturer:		Model:		Serial No.:
Test Personnel:				Date:
Mode: Pre-D:				Post-D:
Single channel measurement technique used:				
RF Input Level		Bit Error Probability		
Channel 1 RF (dBm)	Channel 2 RF (dBm)	Channel 1	Channel 2	Combined
	 X, Y, Z			
				

## **5.5. TEST: Diversity Combiner Dynamic Evaluation with Periodic Out-of-phase Fading and Equal RF Signal Strengths**

5.5.1 Purpose. This test evaluates the dynamic performance of a diversity combiner with periodic out-of-phase fading and equal RF signal strengths.

5.5.2 Test Equipment. Refer to Subsection [5.3.2](#).

5.5.3 Setup. Connect the test equipment as shown in [Figure 5-2](#) and [Figure 5-3](#). See Subsection [5.1.3](#) for additional setup information.

5.5.4 Conditions. Use the test conditions described in Subsection [5.1.4](#).

5.5.5 Procedure

1. Record data on Data Sheet 5-5.
2. Repeat all of Subsection [5.3.5](#), except in step 5 do not remove the 90° delay in one path of the modulation source. The AGC fade envelopes will then be 180° out of phase.

5.5.6 Data Reduction. The BEP at the combiner output should be less than the single-channel BEP at an 8-dB stronger RF power level. If this condition is not true, the combiner and receiver alignment and interconnections should be checked. If everything is correct, the combiner is not working properly.

<b>Data Sheet 5-5. Diversity Combiners</b>				
<b>Test 5.5</b>		<b>Dynamic, equal RF signal strength (out-of-phase fading, 180°)</b>		
<b>Manufacturer:</b>		<b>Model:</b>		<b>Serial No.:</b>
<b>Test Personnel:</b>				<b>Date:</b>
<b>Mode: Pre-D:</b>				<b>Post-D:</b>
<b>Single channel measurement technique used:</b>				
<b>RF Input Level</b>		<b>Bit Error Probability</b>		
Channel 1 (dBm)	Channel 2 (dBm)	Channel 1	Channel 2	Combined

## **5.6. TEST: Diversity Combiner Dynamic Evaluation with Periodic Out-of-Phase Fading and Unequal RF Signal Strengths**

5.6.1 Purpose. This test evaluates the dynamic performance of a diversity combiner with periodic out-of-phase fading and unequal RF signal strengths.

5.6.2 Test Equipment. Refer to Subsection [5.3.2](#).



5.6.3 Setup. Connect the equipment as shown in [Figure 5-2](#) and [Figure 5-3](#). See Subsection [5.1.3](#) for additional setup information.



5.6.4 Conditions. Use the test conditions described in Subsection [5.1.4](#).

5.6.5 Procedure

1. Record data on Data Sheets 5-6(1) and 5-6(2).
2. Check or repeat Subsection [5.3.5](#), except in step 5 do not remove the 90° delay in one path of the modulation source. The AGC fade envelopes will then be 180° out of phase.
3. Repeat steps 3 through 5 in Subsection [5.4.5](#).

5.6.6 Data Reduction. The BEP at the demodulated output of a pre-detection combiner should be less than the BEP of the “best” single channel with a 1-dB weaker RF power level. If this condition is not true, the receiver and combiner alignment and interconnections should be checked. If everything is correct, the combiner is not working properly.

Data Sheet 5-6(1). Diversity Combiners					
Test 5.6		Dynamic, unequal RF signal strength (out-of-phase fading, 180°)			
Manufacturer:		Model:		Serial No.:	
Test Personnel:				Date:	
Mode: Pre-D:				Post-D:	
Single channel measurement technique used:					
RF Input Level		Bit Error Probability			
Channel 1 RF (dBm)	Channel 2 RF (dBm)	Channel 1	Channel 2	Combined	
 X, Y, Z					
					

Data Sheet 5-6(2). Diversity Combiners				
<b>Test 5.6</b>		<b>Dynamic, unequal RF signal strength (out-of-phase fading, 180°)</b>		
<b>Manufacturer:</b>		<b>Model:</b>		<b>Serial No.:</b>
<b>Test Personnel:</b>				<b>Date:</b>
<b>Mode: Pre-D:</b>				<b>Post-D:</b>
<b>Single channel measurement technique used:</b>				
RF Input Level		Bit Error Probability		
Channel 1 RF (dBm)	Channel 2 RF (dBm)	Channel 1	Channel 2	Combined
	 X, Y, Z			
				



## 5.7. TEST: Diversity Combiner Break Frequency

5.7.1 Purpose. This test determines the fading frequency at which the combiner performance starts to degrade significantly. Combiners used in applications where flame or plume attenuation are likely such as missile or launch vehicle tests are subject to very high frequency fade rates.

5.7.2 Test Equipment. Refer to Subsection [5.3.2](#).

5.7.3 Setup. Connect the test equipment as shown in [Figure 5-2](#) and [Figure 5-3](#). See Subsection [5.1.3](#) for additional setup information.

5.7.4 Conditions. Use the test conditions described in Subsection [5.1.4](#).

5.7.5 Procedure

1. Record data on Data Sheet 5-7.
2. Adjust the test setup for the equal RF signal strength out-of-phase fading condition as described in Test [5.5](#). Make sure that the delay in one path from the modulation source to the phase shifter is equivalent to a 90° phase shift at each of the fade rates. Set the fade rates as shown on Data Sheet 5-7.
3. Use the lowest fading rate shown on the data sheet to adjust the average level of the RF fading signals to give a combined BEP of approximately  $10^{-6}$ . Next, measure the dynamic BEP of the single channels. They should be approximately equal. Slight adjustment of the average RF fading signals or adjustment of the fade depths may be required to make the BEP reading approximately equal.
4. Measure the combined BEP for each of the fade rates shown on Data Sheet 5-7. Maintain the 180° out-of-phase condition for each fade rate. Check the single-channel BEP occasionally to ensure that it remains approximately constant.
5. The combined BEP will increase and a fade rate will be reached when the combined BEP has degraded to  $1 \cdot 10^{-4}$ . It may be necessary to interpolate between two fade rates. This fade rate is defined as the break frequency.

5.7.6 Data Reduction. The break frequency should be high enough to handle the highest fade that will be encountered in an operational environmental.

Data Sheet 5-7. Diversity Combiners							
Test 5.7		Dynamic, break frequency					
Manufacturer:			Model:			Serial No.:	
Test Personnel:						Date:	
Mode: Pre-D:						Post-D:	
Single channel measurement technique used:							
Average RF Input level		Static BEP		Approximate Dynamic BEP		Fade Rate (fades/second)	Combined BEP
Channel 1 (dBm)	Channel 2 (dBm)	Channel 1	Channel 2	Channel 1	Channel 2		
		$1 \times 10^{-4}$	$1 \times 10^{-4}$			10	
↓	↓	↓	↓			20	
						50	
						100	
						200	
						500	
						1,000	
						2,000	
						5,000	
						10,000	

## 5.8. TEST: Diversity Combiner Evaluation with Random Fading

5.8.1 Purpose. This test evaluates the dynamic performance of a diversity combiner with random fading.

5.8.2 Test Equipment. Use the equipment listed in Subsection [5.3.2](#), plus two Gaussian noise sources.

5.8.3 Setup. Connect the test equipment as shown in [Figure 5-2](#) and [Figure 5-3](#). See Subsection [5.1.3](#) for additional setup information.

5.8.4 Conditions. Use the test conditions described in Subsection [5.1.4](#).

5.8.5 Procedure

1. Set up for 20-dB fading with sinusoidal signals as described in Subsection [5.3.5](#). Measure the voltages that cause the peaks and nulls of the AGC to occur. This measurement is done by observing the AGC voltage on an oscilloscope and noting the levels of the peaks and nulls.
2. Replace the sinusoid with a dc voltage. Adjust the voltage until the AGC null is observed and measure this voltage. Increase the voltage until the previously noted AGC peak is observed and measure this voltage.
3. Set the dc offset into the phase shifter equal to the voltage that gave the AGC peak and also insert a Gaussian noise signal with rms equal to 0.4 times the voltage (peak minus null) measured previously. This setup will produce random fading. The bandwidth of the noise can be changed to produce different fade rates. The amplitude of the noise must be readjusted to keep the rms equal to 0.4 times the voltage (peak minus null) measured previously.
4. This procedure is repeated for both channels with independent noise sources. Test [5.5](#), Test [5.6](#), and Test [5.7](#) can be repeated with random fading. The data sheets from those tests can be used to record this data.

 <b>NOTE</b>	A reasonable range of noise bandwidths is 500 Hz to 50 kHz.
---	---

5.8.6 Data Reduction. With equal single-channel signal strengths, the BEP at the demodulated output of a pre-detection combiner should be better than the BEPs of the single channels at a 4-dB stronger RF power level. Subparagraphs [5.6.6](#) and [5.7.6](#) apply for unequal signal strengths and break frequency testing.

<b>Data Sheet 5-X. (See Note Below). Diversity Combiners</b>		
<b>Test 5.8</b>	<b>Diversity combiner evaluation with random fading</b>	
<b>Manufacturer:</b>	<b>Model:</b>	<b>Serial No.:</b>
<b>Test Personnel:</b>		<b>Date:</b>
<b>Mode: Pre-D:</b>		<b>Post-D:</b>
<b>Single channel measurement technique used:</b>		
<b>NOTE</b> 	Step 4, Subsection <a href="#">5.8.5</a> guidance is repeated here for Test <a href="#">5.8</a> :  This procedure is repeated for both channels with independent noise sources. Test <a href="#">5.5</a> , Test <a href="#">5.6</a> , and Test <a href="#">5.7</a> can be repeated with random fading. The data sheets from those tests can be used to record this data.	

## 5.9. TEST: Pre-detection Combiner Band Pass Frequency Response using Phase-Modulated Signal

5.9.1 Purpose. This test measures the effective pre-detection band pass bandwidth of the combination of two TM receivers and the diversity combiner.

5.9.2 Test Equipment. An RF signal generator with PM capability, sine-wave generator, two TM receivers (or one dual-channel receiver), microwave counter, microwave spectrum analyzer, RF counter, wave analyzer (or spectrum analyzer), and power splitter.

5.9.3 Test Method. This method measures diversity combiner bandwidth using a phase-modulated carrier and takes advantage of the principle that the amplitudes of the Bessel sidebands of a PM carrier do not change with the modulating frequency (phase deviation held constant). Additionally, this method is well suited to automated testing; however, it is not recommended for manual testing, but it works for diversity combiners, which do not have MGC.

5.9.4 Setup. Connect the test equipment as shown in [Figure 5-5](#).

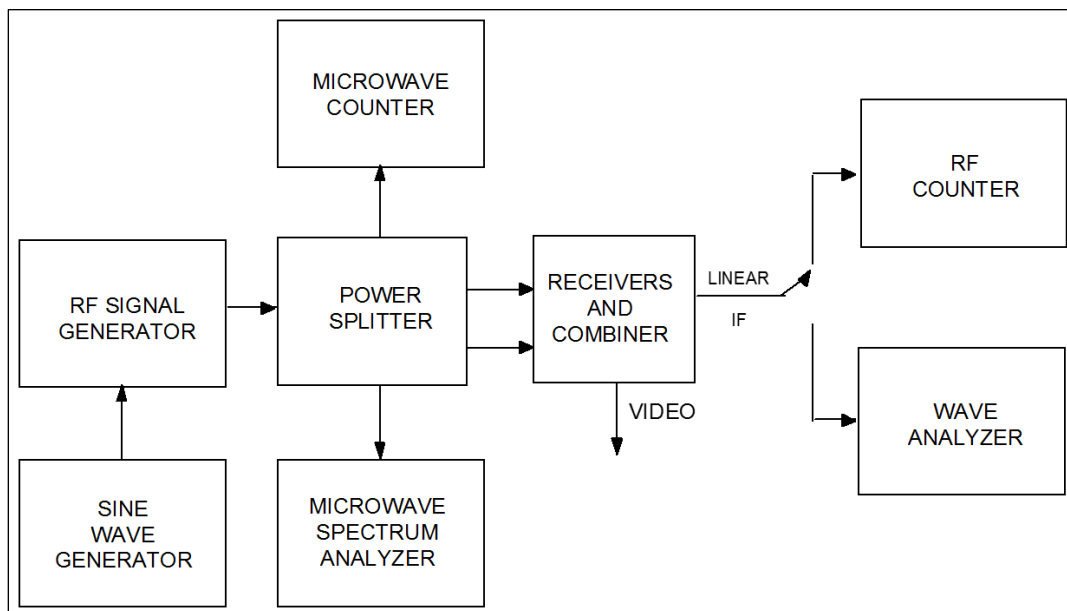



Figure 5-5. Combiner Band Pass Response using Phase-Modulated Signal

5.9.5 Conditions. The RF signal generator frequency should be set to the receiver center frequency, and the output power should be sufficient to give >30-dB IF SNR or as desired. The IF bandwidth of the TM receiver should be set to the widest available value. The wave analyzer (or spectrum analyzer) RBW should be set to 3 kHz. For narrow IF bandwidths, use a RBW no wider than 0.03 times the diversity combiner IF bandwidth.

### 5.9.6 Procedure

1. The first step in this procedure will be to set the peak PM deviation of the RF signal generator to approximately  $82^\circ$ . This setting can be achieved by adjusting the amplitude of the sine-wave generator (frequency = 10 kHz), while monitoring the RF signal using the microwave spectrum analyzer until the carrier component and the first order sidebands are equal in amplitude. (The second order sidebands should be approximately 8 dB lower in

amplitude.) Increase the sine-wave generator frequency to a value equal to two times the diversity combiner IF bandwidth. Use two times the receiver bandwidth if the combiner bandwidth is unknown. Verify that the carrier component and the first order sidebands are within  $\pm 1$  dB of each other. If they are not within  $\pm 1$  dB, the RF generator will not have sufficient bandwidth to perform this test.

 <p><b>NOTE</b></p>	<p>This method will not work if the RF signal generator, TM receivers, or diversity combiner under test has excessive incidental phase, frequency modulation, or frequency drift.</p>
--	---

2. Set the sine-wave generator to a frequency equal to 0.05 times the diversity combiner IF bandwidth. Measure and record the amplitudes of the carrier component and both first order sidebands at the diversity combiner linear IF output. Increase the sine-wave generator frequency in steps of 0.05 times the diversity combiner IF bandwidth. The maximum frequency will be two times the diversity combiner IF bandwidth. Measure and record the amplitudes of the carrier component and both first order sidebands on Data Sheet 5-9.

### 5.9.7 Data Reduction

1. Average the values of the first order sideband amplitudes at a modulation frequency of 0.05 times the IF bandwidth. Subtract this value from the amplitude of the carrier component with this modulating frequency. Use the value as a correction value for all other data points. Subtract the amplitude of the carrier component from each sideband amplitude and add the correction value. Repeat for all modulating frequencies.
2. The 3-dB bandwidth of the IF filter can be calculated by finding the input frequencies where the signal was attenuated by slightly more than 3 dB with respect to the signal at center frequency. Perform a linear interpolation between this frequency and the adjacent frequency where the signal was attenuated by slightly less than 3 dB to find the approximate upper and lower 3-dB frequencies. If the signal were attenuated by  $A_1$  dB at frequency  $f_1$  and  $A_2$  dB at frequency  $f_2$ , the approximate 3-dB frequency would be:

$$f_1 + \frac{A_1 - 3}{A_1 - A_2} (f_2 - f_1) \quad (\text{Eq. 5-1})$$

Let:

$$\begin{aligned} f_1 &= 10.45 \text{ MHz,} \\ f_2 &= 10.5 \text{ MHz,} \\ A_1 &= 2.2 \text{ dB,} \\ A_2 &= 3.2 \text{ dB,} \end{aligned}$$

then:  $f_{-3 \text{ dB}} = 10.45 + \{(2.2 - 3)/(2.2 - 3.2)\} (10.5 - 10.45) = 10.49 \text{ MHz.}$

3. The composite IF filter equivalent noise power bandwidth with respect to the center frequency can be calculated by dividing the measured power at each frequency by the measured power at the center frequency and then multiplying each of these values by the frequency step size and adding all of these values.

<b>Data Sheet 5-9. Diversity Combiners</b>			
<b>Test 5.9</b>	<b>Pre-detection combiner band pass frequency response using phase-modulated signal</b>		
<b>Combiner Manufacturer:</b>		<b>Model:</b>	
<b>Serial No.:</b>			
<b>Combiner IF BW:</b>	kHz	<b>Receiver IF BW:</b>	kHz
<b>Test Personnel:</b>		<b>Date:</b>	
Modulating Frequency (dB)	FC Amplitude (dB)	FC – FM Amplitude (dB)	FC + FM Amplitude (dB)
Upper –3-dB frequency: _____ Lower –3-dB frequency: _____ –3 dB frequency: _____ Equivalent noise power bandwidth: _____			

## 5.10. TEST: Pre-detection Combiner Band Pass Frequency Response using Unmodulated Signal

5.10.1 Purpose. This test measures the effective pre-detection band pass bandwidth of the combination of two TM receivers and the diversity combiner.

5.10.2 Test Equipment. An RF signal generator, power splitter, two TM receivers (or one dual-channel receiver), spectrum analyzer (or wave analyzer) with  $RBW \leq 3$  percent of specified diversity combiner band pass filter bandwidth and effective VBW of  $\leq 1$  percent of RBW, and oscilloscope camera or plotter for recording spectrum analyzer display.

5.10.3 Test Method. This method measures diversity combiner bandwidth using an unmodulated carrier input signal with an IF SNR of approximately 10 to 20 dB. This test can be performed with diversity combiners in the AGC mode. It can also be performed on diversity combiners with only a limited IF output. This test is suited for both manual and computer controlled testing.

5.10.4 Setup. Connect the test equipment as shown in [Figure 5-6](#).

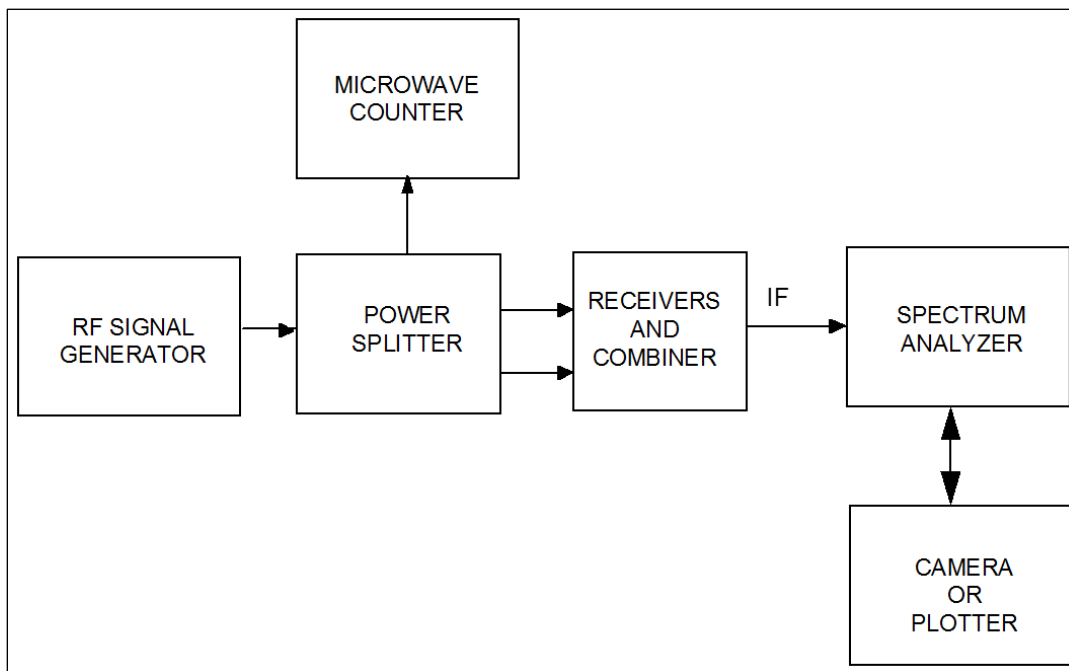

Figure 5-6. Combiner Band Pass Response using Unmodulated Signal

5.10.5 Conditions. Set the RF generator frequency to the receiver center frequency. Adjust the RF generator output power to produce a combiner IF SNR of between 10 and 20 dB. The IF bandwidth of the TM receiver should be set to the widest available value. Set the spectrum analyzer center frequency to the diversity combiner IF output center frequency. Adjust the spectrum analyzer sweep width to sweep from IF center frequency minus 2.5 times specified IF bandwidth to IF center frequency plus 2.5 times specified IF bandwidth. For a diversity combiner with a 10-MHz IF output and a 1-MHz IF bandwidth, the spectrum analyzer would be set to sweep from 7.5 to 12.5 MHz with a 30-kHz RBW and a 300-Hz VBW. If the spectrum analyzer



only has certain span settings, use the smallest setting that is greater than or equal to the calculated setting.

5.10.6 Procedure. Measure and record the noise spectrum at the diversity combiner IF output. Attach the photograph or plot to the Data Sheet 5-10.

5.10.7 Data Reduction. Estimate the gain (loss) at the frequencies listed on Data Sheet 5-10. (Estimate noise power at center frequency not signal power.) Estimate (calculate) the  $-3$ -dB bandwidth of the diversity combiner band pass output. Record this value on Data Sheet 5.10.

<b>Data Sheet 5-10. Diversity Combiners</b>																	
<b>Test 5.10</b>	<b>Pre-detection combiner band pass frequency response using unmodulated signal</b>																
<b>Combiner Manufacturer:</b>	<b>Model:</b>																
<b>Serial No.:</b>																	
<b>Combiner IF BW:</b> kHz	<b>Receiver IF BW:</b> kHz																
<b>Test Personnel:</b>	<b>Date:</b>																
<table border="1" style="margin: auto; border-collapse: collapse;"> <thead> <tr> <th style="width: 50%; padding: 5px;">Frequency</th> <th style="width: 50%; padding: 5px;">Amplitude (dB)</th> </tr> </thead> <tbody> <tr><td style="padding: 5px;"><math>F_0</math></td><td style="padding: 5px;"></td></tr> <tr><td style="padding: 5px;"><math>F_0 - BW/2</math></td><td style="padding: 5px;"></td></tr> <tr><td style="padding: 5px;"><math>F_0 + BW/2</math></td><td style="padding: 5px;"></td></tr> <tr><td style="padding: 5px;"><math>F_0 - BW</math></td><td style="padding: 5px;"></td></tr> <tr><td style="padding: 5px;"><math>F_0 + BW</math></td><td style="padding: 5px;"></td></tr> <tr><td style="padding: 5px;"><math>F_0 - 2 BW</math></td><td style="padding: 5px;"></td></tr> <tr><td style="padding: 5px;"><math>F_0 + 2 BW</math></td><td style="padding: 5px;"></td></tr> </tbody> </table> <p style="margin-top: 20px; text-align: center;"> <math>F_0</math> = IF center frequency      <math>BW</math> = IF bandwidth (-3 dB)                      Estimated -3-dB bandwidth: _____                 </p>		Frequency	Amplitude (dB)	$F_0$		$F_0 - BW/2$		$F_0 + BW/2$		$F_0 - BW$		$F_0 + BW$		$F_0 - 2 BW$		$F_0 + 2 BW$	
Frequency	Amplitude (dB)																
$F_0$																	
$F_0 - BW/2$																	
$F_0 + BW/2$																	
$F_0 - BW$																	
$F_0 + BW$																	
$F_0 - 2 BW$																	
$F_0 + 2 BW$																	

### 5.11. TEST: Combiner Data Frequency Response

5.11.1 Purpose. This test measures the data frequency response of the combination of two TM receivers and a diversity combiner. This test can be performed on either a pre-detection combiner or a post-detection combiner with demodulator.

5.11.2 Test Equipment. Sine-wave generator, RF signal generator that can be frequency modulated or phase-modulated or both, power splitter, two TM receivers (or one dual-channel receiver), microwave counter, oscilloscope, wave analyzer, and microwave spectrum analyzer.

5.11.3 Test Method. This test measures data frequency response by measuring the receiver video output level while varying the modulation frequency. The carrier deviation is kept at a constant value.

5.11.4 Setup. Connect the test equipment as shown in [Figure 5-7](#).

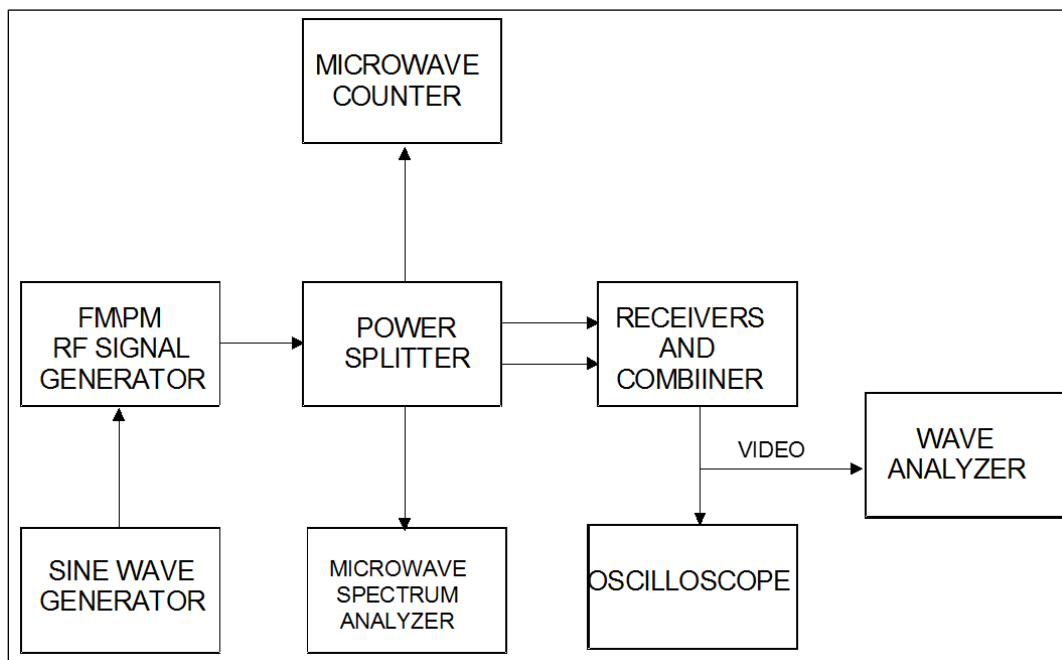



Figure 5-7. Combiner Data Frequency Response

5.11.5 Conditions. The signal generator should be set to an output frequency equal to the receiver center frequency and an output amplitude sufficient to give >30-dB IF SNR. The diversity combiner video output should be set to approximately 0 Vdc with an unmodulated center frequency input.

#### 5.11.6 Procedure

1. The first step in this procedure will be to set the RF signal generator peak deviation. If a diversity combiner with an FM demodulator is being used, set the peak deviation equal to the selected VBW. (The IF bandwidth should be at least twice the VBW.) The peak deviation can be set using Bessel nulls or whatever method the test operator is familiar with. If a diversity combiner with a PM demodulator is being used, set the peak deviation to  $82^\circ$ . Set the sine-wave generator frequency to two times the VBW. Measure the difference (in dB)

between the modulated carrier amplitude and the amplitudes of the first sideband pair. This difference should be 11.8 dB for frequency modulation (sidebands lower than modulated carrier) and 0 dB for PM. If both sidebands are not between 10.8 and 12.8 dB ( $\pm 1$  dB for PM) lower than the modulated carrier, the frequency response of the signal generator is not adequate for this test, and a different signal generator must be used.

 <b>NOTE</b>	This test can also be performed using a spectrum analyzer with tracking generator in place of the sine-wave generator and wave analyzer.
---	--

2. Set the sine-wave generator frequency to one-tenth of the diversity combiner VBW. Maintain the sine-wave generator amplitude equal to the value determined in step 1. Measure the output on the wave analyzer and record on Data Sheet 5-11.
3. Increase the sine-wave generator frequency in steps of one-tenth for the diversity combiner VBW while maintaining the output amplitude constant. The highest sine-wave generator frequency will be equal to twice the diversity combiner VBW. Measure and record the video output on Data Sheet 5-11 for each frequency.

5.11.7 Data Reduction. Subtract the video output amplitude (in dB) at one-tenth the VBW from the amplitude at each of the other frequencies. Record on Data Sheet 5-11.

<b>Data Sheet 5-11. Diversity Combiners</b>			
<b>Test 5.11</b>	<b>Combiner data frequency response</b>		
<b>Combiner Manufacturer:</b>		<b>Model:</b>	
<b>Serial No.:</b>			
<b>Combiner IF BW:</b> kHz		<b>Receiver IF BW:</b> kHz	
<b>Combiner video BW:</b> kHz		<b>Receiver video BW:</b> kHz	
<b>Combiner type: Post-detection:</b>		<b>Pre-detection:</b>	
<b>Demodulator type:</b>	<b>FM:</b>	<b>PM:</b>	<b>Other:(                    )</b>
<b>Test Personnel:</b>		<b>Date:</b>	<b>Location:</b>
<b>Video Bandwidth (VBW)</b>	<b>Frequency</b>	<b>Amplitude (dB)</b>	<b>Relative Amplitude (dB)</b>
0.1			
0.2			
0.3			
0.4			
0.5			
0.6			
0.7			
0.8			
0.9			
1.0			
1.1			
1.2			
1.3			
1.4			
1.5			
1.6			
1.7			
1.8			
1.9			
2.0			

## 5.12. TEST: Combiner Pre-detection Carrier Output

5.12.1 Purpose. This test measures the amplitude, frequency stability, and accuracy of the diversity combiner pre-detection carrier output. Output instability and frequency errors could be caused by problems in any of the TM receiver or diversity combiner local oscillators.

5.12.2 Test Equipment. Two TM receivers (or one dual-channel receiver), RF signal generator, microwave counter, counter, true rms voltmeter, power splitter, and wave analyzer (optional).

5.12.3 Test Method. This test measures the amplitude and frequency of the pre-detection output and is suitable for manual or computer controlled testing. The pre-detection down converter may be in the diversity combiner or in an external accessory housing.

5.12.4 Setup. Connect the test equipment as shown in [Figure 5-8](#).

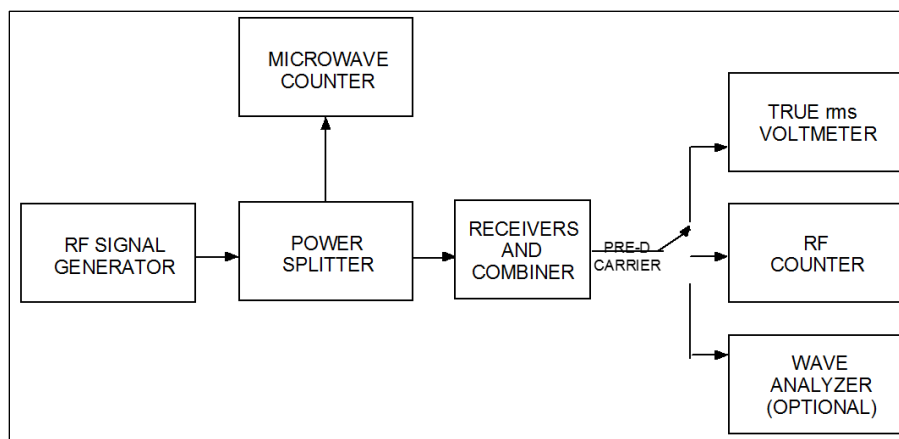

Figure 5-8. Combiner Pre-detection Carrier Output

5.12.5 Conditions. The RF signal generator must be stabilized before the test is started. The TM receivers and diversity combiner should be on for the specified warm-up time before the start of the test. Set the RF signal generator frequency to the center frequency of the TM receiver. Set the RF signal generator output power to  $-50$  dBm.

### 5.12.6 Procedure

1. Select a pre-detection carrier frequency. Measure the amplitude and frequency of the pre-detection output. Record these values on Data Sheet 5-12. The frequency at the diversity combiner input shall also be counted and recorded on Data Sheet 5-12.
2. Repeat step 1 at 5-minute intervals over a 1-hour time interval. The interval between measurements and the total test time can be varied at the discretion of the test personnel.
3. This procedure can be repeated for other pre-detection carriers as desired.

5.12.7 Data Reduction. Record the maximum and minimum frequencies and amplitudes measured. Calculate and record the maximum frequency error (measured frequency – selected frequency).

<b>Data Sheet 5-12. Diversity Combiners</b>			
<b>Test 5.12</b>	<b>Combiner pre-detection carrier output</b>		
<b>Combiner Manufacturer:</b>		<b>Model:</b>	
<b>Serial No.:</b>			
<b>Combiner IF BW:</b> kHz		<b>Receiver IF BW:</b> kHz	
<b>Test Personnel:</b>		<b>Date:</b>	<b>Location:</b>
<b>Carrier frequency:</b> kHz			
<b>Combiner Input</b>		<b>Pre-detection Output</b>	
Time	Frequency	Frequency	Amplitude
<b>Maximum frequency:</b>	kHz		
<b>Minimum frequency:</b>	kHz		
<b>Maximum frequency error:</b>	kHz		
<b>Maximum amplitude:</b>	V rms		
<b>Minimum amplitude:</b>	V rms		

This page intentionally left blank.



## CHAPTER 6

### Test Procedures for Telemetry Downconverters

#### 6. General

This chapter describes the test procedures used to measure the parameters of TM downconverters. Included are methods for determining 1-dB gain compression, saturation level, bandwidth, small-signal power gain, IM products, IP, VSWR, noise figure, channel isolation, spurious signal generation, image rejection, and local oscillator frequency accuracy. These tests are generally performed under laboratory conditions. If, however, the downconverter is to be used under adverse conditions, testing should be accomplished whenever possible under conditions close to those expected during normal operation.

[Table 6-1](#) lists the types of tests and their test and paragraph number.

<b>Table 6-1. Test Matrix For TM Downconverters</b>	
<b>Test Number</b>	<b>Test Description</b>
<a href="#">6.1</a>	Gain compression and saturation level
<a href="#">6.2</a>	Bandwidth and passband gain characteristics
<a href="#">6.3</a>	IM products and intercept point
<a href="#">6.4</a>	Voltage standing wave ratio
<a href="#">6.5</a>	Noise figure
<a href="#">6.6</a>	Channel isolation
<a href="#">6.7</a>	Spurious signal
<a href="#">6.8</a>	Image rejection
<a href="#">6.9</a>	Local oscillator frequency accuracy and stability
<a href="#">6.10</a>	Local oscillator radiation

#### 6.1. TEST: Gain Compression and Saturation Level

6.1.1 **Purpose.** This test measures the 1-dB gain compression point and the saturation level. These tests are important in determining the maximum input signal levels the downconverter can handle without causing distortion of the signal. The 1-dB gain compression point is defined as the point where the gain of a downconverter has decreased 1 dB from the small-signal gain. The saturation level is the maximum output level.

6.1.2 **Test Equipment.** Signal generator, spectrum analyzer, two power meters, power splitter, and terminations (characteristic impedance).

6.1.3 **Test Method.** This test measures the input and output power levels while increasing the input power level.

6.1.4 **Setup.** Connect the test equipment as shown in [Figure 6-1](#). Unused downconverter inputs and outputs should be terminated in their characteristic impedance. If the downconverter is a dual-channel unit, this test should be performed on both channels.

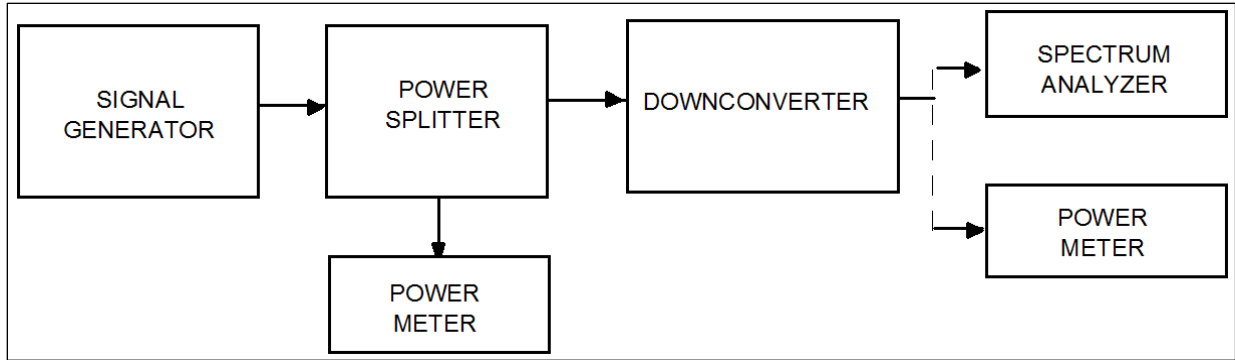

Figure 6-1. Downconverter Gain Compression and Saturation Level Test Setup

6.1.5 Conditions. Perform this test under laboratory conditions after the specified warm-up time. All procedures are conducted with continuous-wave signals (unmodulated) into the device under test. Set the frequency of the signal generator to the center frequency of the downconverter under test.

6.1.6 Procedure

1. Set the generator output level to a value 30 dB below the specified 1-dB gain compression input level of the downconverter. Monitor the output using the spectrum analyzer to verify that no significant spurious signals are present at the downconverter output. If large spurious signals are present, the downconverter may not be usable until the problem is corrected. However, gain compression can be measured by using the spectrum analyzer instead of the power meter to detect output power at desired frequency. The rest of this procedure will assume that no significant spurious signals are present.
2. Connect the power meter to the downconverter output. Measure and record the input and output power levels (in dBm) on Data Sheet 6-1. The difference between the output and input levels is the small-signal gain at center frequency.
3. Increase the input power until the difference between the input and output powers is 1 dB less than the small-signal gain measured in step 2. Record the input and output powers on Data Sheet 6-1.
4. Increase the input power until the output level peaks. Find the smallest input signal level that gives this output level. Record the input and output levels on Data Sheet 6-1.

6.1.7 Data Reduction. Compare the measured values with the specified values.

Data Sheet 6-1. Telemetry Downconverters		
<b>Test 6.1</b>	<b>Gain compression and saturation level</b>	
Downconverter Manufacturer:		Model:
Serial No.:		
Test Personnel:	Date:	Location:
<div style="text-align: right; margin-bottom: 10px;">                     Input frequency: _____ MHz                      Output frequency: _____ MHz                 </div> <div style="text-align: center; margin-bottom: 10px;"> <b><u>Small signal</u></b> _____                 </div> <div style="text-align: right; margin-bottom: 10px;">                     Input power: _____ dBm                      Output power: _____ dBm                      Gain _____ dB                 </div> <div style="text-align: center; margin-bottom: 10px;"> <b><u>1 dB gain compression</u></b> _____                 </div> <div style="text-align: right; margin-bottom: 10px;">                     Input power: _____ dBm                      Output power: _____ dBm                      Gain _____ dB                 </div> <div style="text-align: center; margin-bottom: 10px;"> <b><u>Saturation level</u></b> _____                 </div> <div style="text-align: right;">                     Input power: _____ dBm                      Output power: _____ dBm                 </div>		

## 6.2. TEST: Bandwidth and Passband Gain Characteristics

6.2.1 Purpose. This test measures the passband gain characteristics. Bandwidth is defined as the maximum range of frequencies over which the amplitude response does not decrease more than 3 dB from the reference point. These tests ensure that the downconverter will operate properly over the intended frequency band and that the downconverters gain performance will be fairly uniform across the band.

6.2.2 Test Equipment. Signal generator, spectrum analyzer, two power meters, power splitter, and terminations (characteristic impedance).

6.2.3 Test Method. This test measures the input and output power levels while the input frequency is varied.

6.2.4 Setup. Connect the test equipment as shown in [Figure 6-2](#). Unused downconverter inputs and outputs should be terminated in their characteristic impedance. If the downconverter is a dual-channel unit, this test should be performed on both channels.

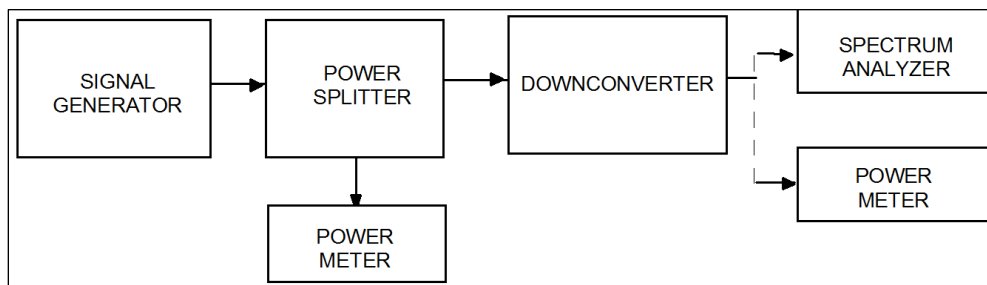

Figure 6-2. Downconverter Bandwidth and Passband Gain Characteristics

6.2.5 Conditions. Perform this test under laboratory conditions after the specified warm-up time. All procedures are conducted with continuous-wave signals (unmodulated) into the device under test.

### 6.2.6 Procedure

1. Set the signal generator frequency to the center of the passband of the device under test. Set the signal generator level to a value 20 dB below the 1-dB gain compression input level measured in Test [6.1](#). Measure the input and output power levels. The output power levels can be measured using either the power meter or spectrum analyzer. Record on Data Sheet 6-2.
2. Set the signal generator frequency to the lowest frequency in the specified band pass. Measure the input and output power levels and record on Data Sheet 6-2.
3. Set the signal generator frequency to the highest frequency in the specified band pass. Measure the input and output powers and record on Data Sheet 6-2.
4. Tune the signal generator across the band of interest. Note and record any abnormal changes in gain versus frequency on Data Sheet 6-2. Continue tuning until response drops approximately 10 dB to ensure that the actual downconverter band edges have been reached. Retune the signal generator and record the  $-3$ -dB points (relative to center frequency gain) on Data Sheet 6-2.

5. This test can also be performed using a sweep generator and network analyzer or a wide-band noise source and a spectrum analyzer in place of the signal generator and output power meter.

6.2.7 Data Reduction. Calculate the gain by subtracting the input power from the output power. Record on Data Sheet 6-2 in the gain column.

<b>Data Sheet 6-2. Telemetry Downconverters</b>			
<b>Test 6.2</b>	<b>Bandwidth and passband gain characteristic</b>		
Downconverter Manufacturer:		Model:	
Serial No.:			
Test Personnel:		Date:	Location:
	<b>Input</b>	<b>Output</b>	<b>Gain</b>
Center frequency (per specification)	MHz	MHz	
	dBm	dBm	dB
Lowest frequency (per specification)	MHz	MHz	
	dBm	dBm	dB
Highest frequency (per specification)	MHz	MHz	
	dBm	dBm	dB
Low -3-dB frequency	MHz	MHz	dB
	dBm	dBm	
High -3-dB frequency	MHz	MHz	dB
	dBm	dBm	

### 6.3. TEST: Downconverter IM Products and Intercept Point

6.3.1 **Purpose.** This test measures the IM products and IP of a downconverter. These tests determine a downconverter's ability to operate properly in the presence of multiple input signals. Multiple high-level input signals, as can be found in many "RF-rich" environments, can create situations in which interfering signals are generated internal to the downconverter. The IM products and intercept point are discussed in more detail in [Appendix A](#).

6.3.2 **Test Equipment.** Two signal generators, two isolators or 10-dB attenuators (20 dB if resistive combiner used), power combiner, spectrum analyzer, and terminations (characteristic impedance).

6.3.3 **Test Method.** Two RF signals are summed and applied to the downconverter input. The output spectrum is measured. The third-order intercept point is calculated from the relative amplitudes of the fundamental and third-order outputs.

6.3.4 **Setup.** Connect the test equipment as shown in [Figure 6-3](#).

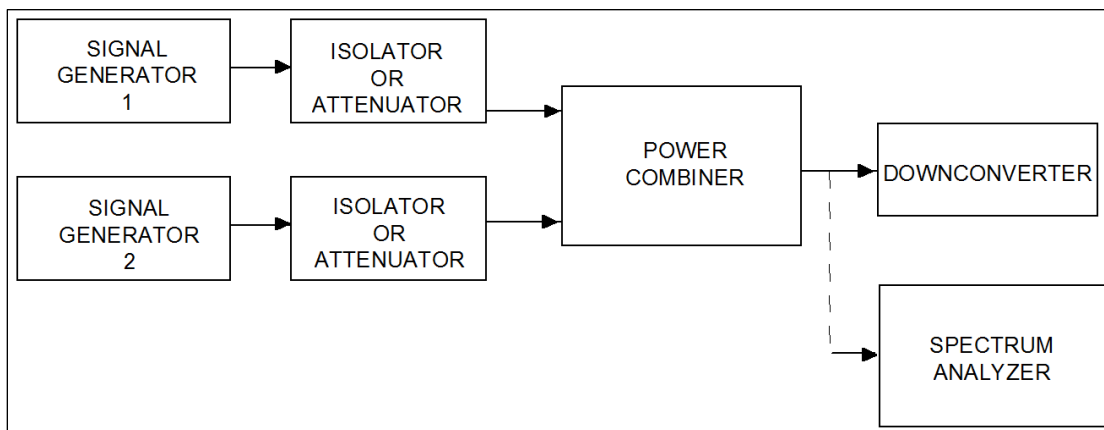

Figure 6-3. Intermodulation Products and Intercept Point Test Setup

6.3.5 **Conditions.** Perform this test under laboratory conditions after the specified warm-up time. All procedures are conducted with continuous-wave signals (unmodulated) into the device under test. The isolators (or attenuators) between the signal generators and power combiner provide isolation between the generators to minimize interference between the generators. Spurious outputs or incidental PM may degrade the accuracy of the results of this test. All unused downconverter signal inputs and outputs should be terminated in their characteristic impedance.

#### 6.3.6 Procedure

1. Set the frequencies of the fundamental signals ( $f_{11}$  and  $f_{12}$ ) near the mid-band frequency of the downconverter under test. The spacing of the fundamental signals is not critical as long as the third-order products are within the downconverter passband; that is,  $2f_1 - f_2$  and  $2f_2 - f_1$  must be within the downconverter bandwidth.
2. Set the output level of each signal generator to a convenient reference level, for example,  $-50$  dBm. Connect the spectrum analyzer to the power combiner output and observe the spectrum. Adjust the display width to include the two fundamentals and the two third-order

IM products as shown in [Figure 6-4](#). Only signals at frequencies  $f_{i1}$  and  $f_{i2}$  should appear. Increase the output power of both signal generators in 10-dB steps until the amplitude of each signal is  $-20$  dBm (or at least 10 dB below the 1-dB compression level measured in [Test 6.1](#)) as measured on the spectrum analyzer. The signals should increase in 10-dB steps, and no extraneous signals should be present. This technique ensures that IM products are not being produced in the power combiner or spectrum analyzer.

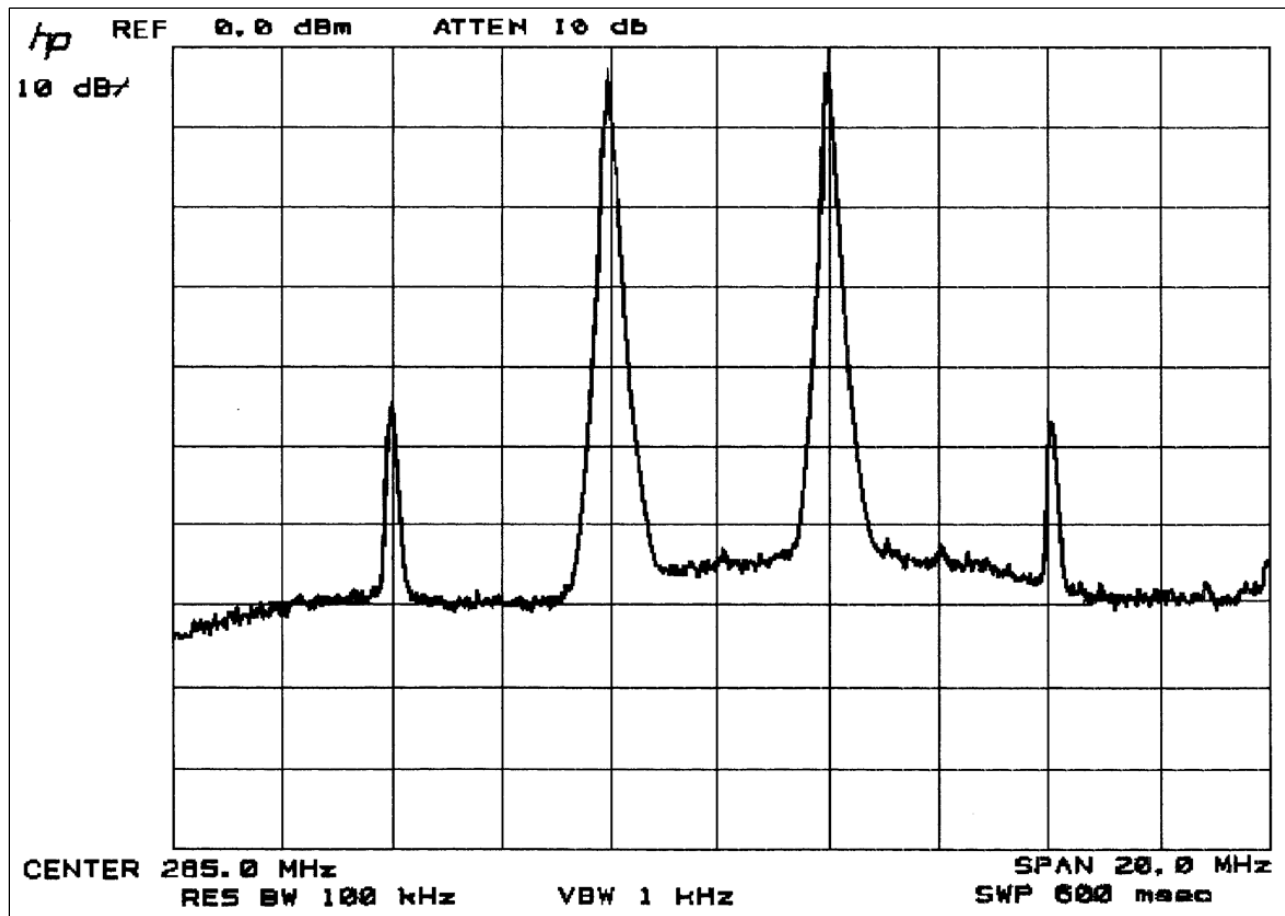

Figure 6-4. Downconverter Intermodulation Products



**NOTE** Spectrum analyzers may produce IM products when a high-level signal is applied to the input. If IM products occur, attenuate the signal at the input to the spectrum analyzer. Most analyzers have a built-in attenuator.

3. Reconnect the downconverter between the power combiner and the spectrum analyzer. With the power at the input of the downconverter at  $-20$  dBm (or other input level at least 10 dB below 1-dB compression level), measure and record on Data Sheet 6-3 the power levels at frequencies of  $f_1$ ,  $f_2$ ,  $2f_1 - f_2$ , and  $2f_2 - f_1$ .
4. Reduce both input power levels to the downconverter in 10-dB steps. Measure and record on Data Sheet 6-3 the power levels at frequencies of  $f_1$ ,  $f_2$ ,  $2f_1 - f_2$ , and  $2f_2 - f_1$ . Continue to reduce the input power levels until the third-order IM products decrease to the noise floor.



6.3.7 Data Reduction. The third-order intercept point can be calculated using (all values in dBm):

$$IP_{o3} = \frac{3}{2} P_o - \frac{IM_{o3}}{2} \quad (\text{Eq. 6-1})$$

Where:

$IP_{03}$  = the calculated output power at which the power of the third-order IM product is equal to the power of the fundamental signal

$P_o$  = measured fundamental output power (higher of two measured values)

$IM_{03}$  = measured third-order IM power (higher value)

The calculated third-order intercept point ( $IP_{03}$ ) should be similar for each input power level. As discussed in [Appendix A](#), the third-order intercept point can be used to estimate the IM power for any pair of input signals of equal amplitude and can also be used to calculate the spurious free dynamic range. The third-order intercept point will usually be approximately 10 dB higher than the 1-dB gain compression point output power (see Test [6.1](#)).

Data Sheet 6-3. Telemetry Downconverters																		
<b>Test 6.3</b>		<b>Intermodulation products and intercept point</b>																
Downconverter Manufacturer:				Model:														
Serial No.:																		
Test Personnel:			Date:		Location:													
<table border="1" style="margin: auto; border-collapse: collapse;"> <thead> <tr> <th colspan="2" style="text-align: center; padding: 5px;"><u>FREQUENCY</u></th> </tr> <tr> <th style="text-align: center; padding: 5px;"><u>Input</u></th> <th style="text-align: center; padding: 5px;"><u>Output</u></th> </tr> </thead> <tbody> <tr> <td style="padding: 5px;"><math>f_1</math> _____ MHz</td> <td style="padding: 5px;"><math>f_1</math> _____ MHz</td> </tr> <tr> <td style="padding: 5px;"><math>f_2</math> _____ MHz</td> <td style="padding: 5px;"><math>f_2</math> _____ MHz</td> </tr> <tr> <td></td> <td style="padding: 5px;"><math>2f_1 - f_2</math> _____ MHz</td> </tr> <tr> <td></td> <td style="padding: 5px;"><math>2f_2 - f_1</math> _____ MHz</td> </tr> </tbody> </table>							<u>FREQUENCY</u>		<u>Input</u>	<u>Output</u>	$f_1$ _____ MHz	$f_1$ _____ MHz	$f_2$ _____ MHz	$f_2$ _____ MHz		$2f_1 - f_2$ _____ MHz		$2f_2 - f_1$ _____ MHz
<u>FREQUENCY</u>																		
<u>Input</u>	<u>Output</u>																	
$f_1$ _____ MHz	$f_1$ _____ MHz																	
$f_2$ _____ MHz	$f_2$ _____ MHz																	
	$2f_1 - f_2$ _____ MHz																	
	$2f_2 - f_1$ _____ MHz																	
<b>Power (dBm)</b>																		
<b>Inputs</b>		<b>Outputs</b>																
$f_1$	$f_2$	$f_1$	$f_2$	$2f_1 - f_2$	$2f_2 - f_1$	$IP_{03}$												

## 6.4. TEST: VSWR

6.4.1 **Purpose.** This test determines the quality of the impedance match of the device under test by measuring the VSWR. Reflections of the signal, caused by an impedance mismatch, can result in distortion of the signal and a reduction in signal power.

6.4.2 **Test Equipment.** Sweep generator, standing wave ratio (SWR) test set, network analyzer, terminations (characteristic impedance), and RF short.

6.4.3 **Test Method.** This test measures VSWR using a network analyzer. See Tests [2.4](#) and [3.4](#) for alternate methods using a spectrum analyzer.

6.4.4 **Setup.** Connect the test equipment as shown in [Figure 6-5](#).

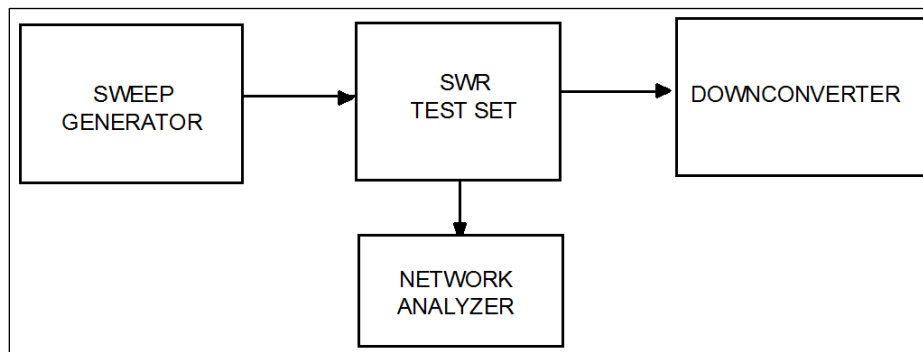

Figure 6-5. Downconverter VSWR Test Setup

6.4.5 **Conditions.** Perform this test under laboratory conditions after the specified warm-up time. All procedures are conducted with CLOCKWISE signals (unmodulated) into the device under test. Follow procedures recommended in network analyzer operating manual.

### 6.4.6 Procedure

1. Set the sweep generator frequency to the sweep across the passband of the downconverter under test and adjust the calibrated attenuator for a level of about  $-40$  dBm into the SWR test set.
2. Connect the short circuit termination to the SWR test set and establish a convenient reference level on the network analyzer. A 0-dB reference is very convenient to use with the network analyzer set for a log display.
3. Remove the short circuit termination and connect the downconverter input to the SWR test set. Terminate the downconverter output port with its characteristic impedance. Observe the signal level on the network analyzer. The difference between the reference level established in step 2 and the new level in dB is the return loss.
4. Record the return loss in dB at convenient increments across the band on Data Sheet 6-4. Note and record any abnormal changes in return loss versus frequency as the generator is tuned.
5. Reverse the downconverter connection in the test setup and repeat steps 2 through 4 (using output frequency passband) to obtain the downconverter output return loss.

6.4.7 Data Reduction. The VSWR can be calculated from the return loss using the following equation:

$$L_R = 20 \log \left( \frac{1}{\rho} \right) \quad (\text{Eq. 6-2})$$

$$\rho = \frac{1}{\text{anti log} (L_R / 20)} \quad (\text{Eq. 6-3})$$

$$\text{VSWR} = \frac{1 + \rho}{1 - \rho} \quad (\text{Eq. 6-4})$$

Where:

$L_R$  = return loss measured

$\rho$  = reflection coefficient of load being measured

**Note:** See [Table 3-2](#).



## 6.5. TEST: Noise Figure

6.5.1 Purpose. This test measures the noise figure that is the ratio of the input signal to noise divided by the output signal to noise expressed in dB. See [Appendix B](#) for a discussion of noise figure. The noise figure of a device is a measure of how much noise is added to the signal by that device. The lower the noise figure, the better the device.

6.5.2 Test Equipment. Noise figure meter, noise source, and terminations (characteristic impedance).

6.5.3 Test Method. This test measures noise figure using a calibrated noise source and an automatic noise figure meter.

6.5.4 Setup. Connect the test equipment as shown in [Figure 6-6](#).

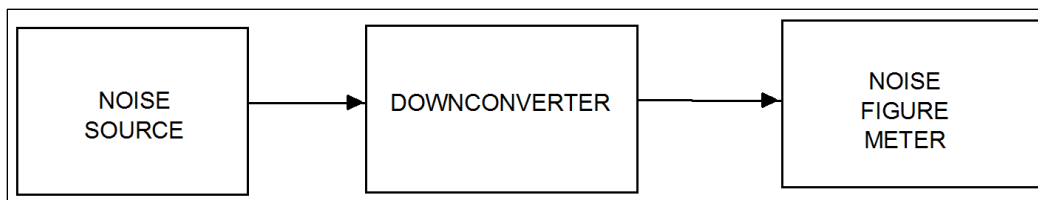
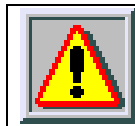

Figure 6-6. Downconverter Noise Figure Test Setup

6.5.5 Conditions. Perform this test under laboratory conditions after the specified warm-up time. Carefully follow operating procedures and cautions in noise figure manual. If possible, this test should be conducted with an automatic noise figure meter in the fixed external local oscillator with variable frequency IF mode. See Tests [2.5](#), [2.6](#), [3.5](#), or [4.2](#) for alternate test configurations if this type of meter is not available.



Field effect transistor amplifiers can be damaged by noise spikes.

### 6.5.6 Procedure

1. Configure noise figure meter to operate in fixed external local oscillator with variable frequency IF mode. Calibrate noise figure meter using method recommended in the manual.
2. Reconnect test equipment as shown in [Figure 6-6](#). Measure the noise figure in 10-MHz steps by varying the measurement frequency of the noise figure meter. Record these values on Data Sheet 6-5.
3. Find the maximum noise figure by sweeping the measurement frequency across the band in 1-MHz steps. Record the frequency and noise figure on Data Sheet 6-5.

6.5.7 Data Reduction. Compare the measured values to the specification.

<b>Data Sheet 6-5. Telemetry Downconverters</b>																						
<b>Test 6.5</b>	<b>Noise figure</b>																					
Downconverter Manufacturer:		Model:																				
Serial No.:																						
Test Personnel:	Date:	Location:																				
<table style="width: 100%; border-collapse: collapse;"> <thead> <tr> <th style="width: 50%; border-bottom: 1px solid black; text-align: center;"><u>Measurement Frequency (MHz)</u></th> <th style="width: 50%; border-bottom: 1px solid black; text-align: center;"><u>Noise Figure (dB)</u></th> </tr> </thead> <tbody> <tr><td style="border-bottom: 1px solid black;"></td><td style="border-bottom: 1px solid black;"></td></tr> <tr><td style="border-bottom: 1px solid black;"></td><td style="border-bottom: 1px solid black;"></td></tr> <tr><td style="border-bottom: 1px solid black;"></td><td style="border-bottom: 1px solid black;"></td></tr> <tr><td style="border-bottom: 1px solid black;"></td><td style="border-bottom: 1px solid black;"></td></tr> <tr><td style="border-bottom: 1px solid black;"></td><td style="border-bottom: 1px solid black;"></td></tr> <tr><td style="border-bottom: 1px solid black;"></td><td style="border-bottom: 1px solid black;"></td></tr> <tr><td style="border-bottom: 1px solid black;"></td><td style="border-bottom: 1px solid black;"></td></tr> <tr><td style="border-bottom: 1px solid black;"></td><td style="border-bottom: 1px solid black;"></td></tr> <tr><td style="border-bottom: 1px solid black;"></td><td style="border-bottom: 1px solid black;"></td></tr> </tbody> </table>			<u>Measurement Frequency (MHz)</u>	<u>Noise Figure (dB)</u>																		
<u>Measurement Frequency (MHz)</u>	<u>Noise Figure (dB)</u>																					

## 6.6. TEST: Channel Isolation

6.6.1 Purpose. This test measures the isolation in dB between channels of a dual-channel downconverter. Omit this procedure when testing single-channel downconverters. A dual-channel downconverter is one in which two RF channels, usually housed in a single chassis, are downconverted using a common local oscillator. Good isolation is necessary to ensure negligible crosstalk between channels of the downconverter.

6.6.2 Test Equipment. Signal generator, spectrum analyzer, and terminations (characteristic impedance).

6.6.3 Test Method. This test measures the isolation between two downconverter channels by applying a large signal to one channel and monitoring the other channel.

6.6.4 Setup. Connect the test equipment as shown in [Figure 6-7](#).

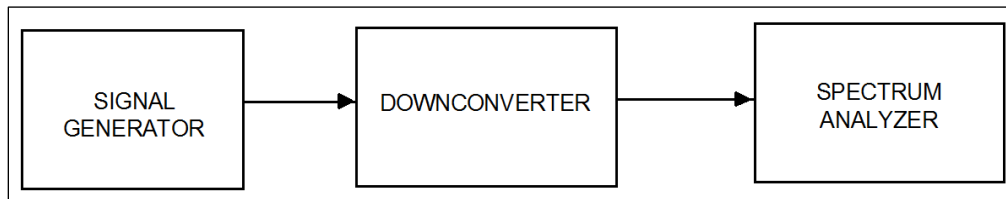

Figure 6-7. Downconverter Channel Isolation Test Setup

6.6.5 Conditions. Perform this test under laboratory conditions after the warm-up time of at least 30 minutes.

### 6.6.6 Procedure

1. Set the signal generator frequency to the center of the passband and set the generator output level to the maximum specified input level of the downconverter. Set the spectrum analyzer center frequency equal to the signal generator frequency. Measure the generator output signal power using the spectrum analyzer and record on Data Sheet 6-6.
2. Connect the signal generator to the channel 1 input port. Connect the spectrum analyzer to the input of channel 2 and terminate the channel 1 and 2 outputs in their characteristic impedance. Measure the signal power (if discernible) at the channel 2 input and record on Data Sheet 6-6.
3. Connect the spectrum analyzer to the channel 1 output port and adjust the analyzer center frequency to be equal to the downconverter output frequency. Terminate the channel 2 input and output in their characteristic impedance. Measure the signal power at the channel 1 output and record on Data Sheet 6-6.
4. Connect the spectrum analyzer to the output of channel 2 and terminate the channel 1 output in its characteristic impedance. Measure the signal power (if discernible) at the channel 2 output and record on Data Sheet 6-6.
5. Repeat steps 1 through 4 with channels 1 and 2 swapped.
6. Repeat steps 1 through 5 for other frequencies as desired.



6.6.7 Data Reduction. Calculate the isolation between the two inputs by subtracting the signal output (in dB) of the unused input from the input power. Calculate the isolation between the channels by subtracting the signal output (in dB) of the unused output from the output power of the driven channel. Record these values on Data Sheet 6-6.

<b>Data Sheet 6-6. Telemetry Downconverters</b>																													
<b>Test 6.6</b>		<b>Channel isolation</b>																											
Downconverter Manufacturer:				Model:																									
Serial No.:																													
Test Personnel:		Date:		Location:																									
<p>Input frequency: _____ MHz</p> <p>Input power: _____ dBm</p>																													
<table border="1" style="width: 100%; border-collapse: collapse;"> <thead> <tr> <th colspan="3" style="text-align: center; padding: 5px;"><b>INPUT POWER (dBm)</b></th> <th colspan="3" style="text-align: center; padding: 5px;"><b>OUTPUT POWER (dBm)</b></th> </tr> <tr> <th style="text-align: center; padding: 5px;">Channel</th> <th style="text-align: center; padding: 5px;">Other Input</th> <th style="text-align: center; padding: 5px;">Isolation</th> <th style="text-align: center; padding: 5px;">Channel 1</th> <th style="text-align: center; padding: 5px;">Channel 2</th> <th style="text-align: center; padding: 5px;">Isolation</th> </tr> </thead> <tbody> <tr> <td style="text-align: center; padding: 5px;">1</td> <td style="text-align: center; padding: 5px;">_____</td> <td style="text-align: center; padding: 5px;">_____ dB</td> <td style="text-align: center; padding: 5px;">_____</td> <td style="text-align: center; padding: 5px;">_____</td> <td style="text-align: center; padding: 5px;">_____ dB</td> </tr> <tr> <td style="text-align: center; padding: 5px;">2</td> <td style="text-align: center; padding: 5px;">_____</td> <td style="text-align: center; padding: 5px;">_____ dB</td> <td style="text-align: center; padding: 5px;">_____</td> <td style="text-align: center; padding: 5px;">_____</td> <td style="text-align: center; padding: 5px;">_____ dB</td> </tr> </tbody> </table>						<b>INPUT POWER (dBm)</b>			<b>OUTPUT POWER (dBm)</b>			Channel	Other Input	Isolation	Channel 1	Channel 2	Isolation	1	_____	_____ dB	_____	_____	_____ dB	2	_____	_____ dB	_____	_____	_____ dB
<b>INPUT POWER (dBm)</b>			<b>OUTPUT POWER (dBm)</b>																										
Channel	Other Input	Isolation	Channel 1	Channel 2	Isolation																								
1	_____	_____ dB	_____	_____	_____ dB																								
2	_____	_____ dB	_____	_____	_____ dB																								

## 6.7. TEST: Spurious Signal

6.7.1 Purpose. This test measures the spurious signals generated by the downconverter. Spurious signals are defined as any undesired signals in the downconverter output. Some spurious signals are generated by the downconverter (that is, local oscillator related spurs) and some are the result of IM products formed by the mixing of strong input signals. Refer to [Appendix A](#) for a discussion of IM products.

6.7.2 Test Equipment. Signal generator, spectrum analyzer, and terminations (characteristic impedance).

6.7.3 Setup. Connect the test equipment as shown in [Figure 6-8](#). Unused downconverter inputs and outputs should be terminated in their characteristic impedance. If the downconverter is a dual-channel unit, this test should be performed on both channels.



Figure 6-8. Downconverter Spurious Signal Generation

6.7.4 Conditions. Perform this test under laboratory conditions after the specified warm-up time. All procedures are conducted with continuous-wave signals (unmodulated) into the device under test.

### 6.7.5 Procedure

1. Set the signal generator frequency to the center of the passband for the device under test. Set the signal generator level to a value 20 dB below the 1-dB gain compression input level measured in Test [6.1](#). Connect the spectrum analyzer to the signal generator output. Verify that no spurious signals are present at the signal generator output.
2. Connect the signal generator to the downconverter input and the spectrum analyzer to the downconverter output. Monitor the spectrum from 10 MHz to 10 GHz. Record the frequency and power of any extraneous signals that are less than 60 dB below the desired output signal in Data Sheet 6-7.

6.7.6 Data Reduction. Annotate the data sheet if the detected signal is a harmonic of the desired signal (harmonic distortion) or equal to the local oscillator frequency (local oscillator feed through).

<b>Data Sheet 6-7. Telemetry Downconverters</b>		
<b>Test 6.7</b>	<b>Spurious signal generation</b>	
<b>Downconverter Manufacturer:</b>		<b>Model:</b>
<b>Serial No.:</b>		
<b>Test Personnel:</b>	<b>Date:</b>	<b>Location:</b>
<div style="display: flex; justify-content: space-between;"> <div style="width: 45%;"> <p>Input frequency: _____</p> <p>Signal output frequency: _____</p> <p>Local oscillator frequency: _____</p> <p>Input power: _____ dBm</p> <p>Signal output power: _____ dBm</p> </div> <div style="width: 50%; text-align: right;"> <p>MHz</p> <p>MHz</p> <p>MHz</p> <p>dBm</p> <p>dBm</p> </div> </div>		
<b>Spurious Signals</b>		
<b>Frequency (MHz)</b>		<b>Power (dBm)</b>

## 6.8. TEST: Image Rejection

6.8.1 Purpose. This test measures the image rejection of the downconverter. Image rejection is defined as the ratio of the power of the desired sideband input signal to the undesired sideband input signal (image signal) as measured at the downconverter output. Every device using a mixer and a local oscillator such as a downconverter or receiver is essentially tuned to two frequencies at the same time. This test measures the downconverter's ability to differentiate between the band of frequencies the tester wants to pass versus the band of frequencies the tester wants to reject.

6.8.2 Test Equipment. Sweep generator, spectrum analyzer, and terminations (characteristic impedance).

6.8.3 Test Method. This test determines image rejection by finding the difference in output amplitude between an input signal in the specified input band and an input at a frequency equally spaced on the other side of the local oscillator.

6.8.4 Setup. Connect the test equipment as shown in [Figure 6-9](#). Unused downconverter inputs and outputs should be terminated in their characteristic impedance. If the downconverter is a dual-channel unit, this test should be performed on both channels.

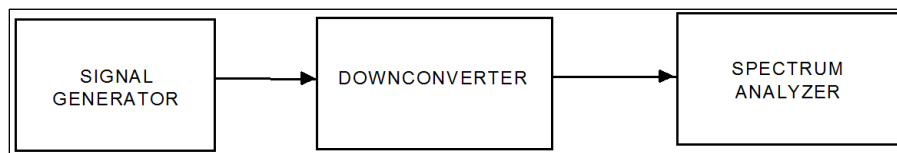

Figure 6-9. Image Rejection Test Setup

6.8.5 Conditions. Perform this test under laboratory conditions after the specified warm-up time. All procedures are conducted with continuous-wave signals (unmodulated) into the device under test.

### 6.8.6 Procedure

1. Set the sweep generator to slowly sweep across the band of frequencies equal to two times the local oscillator frequency minus the specified input frequency range. For example, if the specified input frequency range was 2200 to 2300 MHz and the local oscillator frequency was 1985 MHz, the sweep generator would be set to sweep from  $2(1985) - (2200 \text{ to } 2300)$  or 1770 to 1670 MHz. Set the sweep generator level to a value 20 dB below the 1-dB gain compression input level measured in [Test 6.1](#). Connect the spectrum analyzer to the sweep generator output. Verify that no spurious signals are present at the sweep generator output.
2. Connect the sweep generator to the downconverter input and the spectrum analyzer to the downconverter output. Monitor the spectrum in the frequency band of interest (215 to 315 MHz for the previous example). Note the frequencies where the signal is the largest. Put the sweep generator in fixed frequency mode and find the input and output frequency and output power of the largest signal and record on Data Sheet 6-8.
3. Set the sweep generator frequency equal to two times the local oscillator frequency minus the input frequency that produced the largest amplitude mentioned previously. For example, if an input frequency of 1700 MHz produced the largest output and the local oscillator frequency was 1985 MHz, set the sweep generator frequency to 2270 MHz. Record the input and output frequencies and output power on Data Sheet 6-8.

6.8.7 Data Reduction. Calculate the image rejection by subtracting the power measured in step 2 from the power measured in step 3.

<b>Data Sheet 6-8. Telemetry Downconverters</b>																																																																	
<b>Test 6.8</b>	<b>Image Rejection</b>																																																																
<b>Downconverter Manufacturer:</b>				<b>Model:</b>																																																													
<b>Serial No.:</b>																																																																	
<b>Test Personnel:</b>		<b>Date:</b>		<b>Location:</b>																																																													
Input power: _____ dBm																																																																	
<table border="1" style="width: 100%; border-collapse: collapse;"><thead><tr><th style="width: 16.6%;">Frequency Input</th><th style="width: 16.6%;">Image Level (MHz) (dBm) Output</th><th style="width: 16.6%;">Frequency Output</th><th style="width: 16.6%;">Signal Level (MHz) (dBm) Input</th><th style="width: 16.6%;">Image Rejection Output</th><th style="width: 16.6%;">Output (dB)</th></tr></thead><tbody><tr><td>_____</td><td>_____</td><td>_____</td><td>_____</td><td>_____</td><td>_____</td></tr><tr><td>_____</td><td>_____</td><td>_____</td><td>_____</td><td>_____</td><td>_____</td></tr><tr><td>_____</td><td>_____</td><td>_____</td><td>_____</td><td>_____</td><td>_____</td></tr><tr><td>_____</td><td>_____</td><td>_____</td><td>_____</td><td>_____</td><td>_____</td></tr><tr><td>_____</td><td>_____</td><td>_____</td><td>_____</td><td>_____</td><td>_____</td></tr><tr><td>_____</td><td>_____</td><td>_____</td><td>_____</td><td>_____</td><td>_____</td></tr><tr><td>_____</td><td>_____</td><td>_____</td><td>_____</td><td>_____</td><td>_____</td></tr><tr><td>_____</td><td>_____</td><td>_____</td><td>_____</td><td>_____</td><td>_____</td></tr><tr><td>_____</td><td>_____</td><td>_____</td><td>_____</td><td>_____</td><td>_____</td></tr></tbody></table>						Frequency Input	Image Level (MHz) (dBm) Output	Frequency Output	Signal Level (MHz) (dBm) Input	Image Rejection Output	Output (dB)	_____	_____	_____	_____	_____	_____	_____	_____	_____	_____	_____	_____	_____	_____	_____	_____	_____	_____	_____	_____	_____	_____	_____	_____	_____	_____	_____	_____	_____	_____	_____	_____	_____	_____	_____	_____	_____	_____	_____	_____	_____	_____	_____	_____	_____	_____	_____	_____	_____	_____	_____	_____	_____	_____
Frequency Input	Image Level (MHz) (dBm) Output	Frequency Output	Signal Level (MHz) (dBm) Input	Image Rejection Output	Output (dB)																																																												
_____	_____	_____	_____	_____	_____																																																												
_____	_____	_____	_____	_____	_____																																																												
_____	_____	_____	_____	_____	_____																																																												
_____	_____	_____	_____	_____	_____																																																												
_____	_____	_____	_____	_____	_____																																																												
_____	_____	_____	_____	_____	_____																																																												
_____	_____	_____	_____	_____	_____																																																												
_____	_____	_____	_____	_____	_____																																																												
_____	_____	_____	_____	_____	_____																																																												

## 6.9. TEST: Local Oscillator Frequency Accuracy and Stability

6.9.1 **Purpose.** This test measures the frequency accuracy and stability of the local oscillator. These are important parameters in determining how close the downconverter output frequency will be to its intended frequency. Local oscillator inaccuracies or drifting will cause the output frequency to be off, and potentially, the corresponding TM receiver to be mistuned.

6.9.2 **Test Equipment.** Two frequency counters, RF signal generator and power splitter.

6.9.3 **Test Method.** This test measures the output frequency with a known input frequency. The local oscillator frequency is calculated by subtracting the output frequency from the input frequency. If the local oscillator signal is available as a test point, the local oscillator frequency can be directly measured and recorded on Data Sheet 6-9.

6.9.4 **Setup.** Connect the test equipment as shown in [Figure 6-10](#).

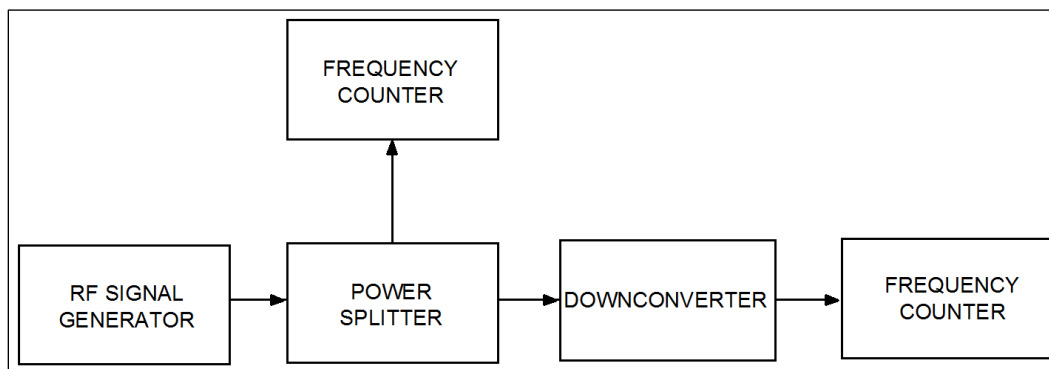

Figure 6-10. Local Oscillator Frequency Accuracy and Stability

6.9.5 **Conditions.** Perform this test under laboratory conditions after the specified warm-up time.

### 6.9.6 Procedure

1. Set the input frequency to the center of the passband. Set the input amplitude to  $-20$  dBm. Count the downconverter input and output frequencies. Record the time of day and frequencies on Data Sheet 6-9.
2. Set the input frequency to the highest frequency in the passband. Count the downconverter input and output frequencies. Record the time of day and frequencies on Data Sheet 6-9. If the output frequency is higher than measured in step 1, the local oscillator frequency is lower than the input frequency. If the output frequency is lower than measured in step 1, the local oscillator frequency is higher than the input frequency.
3. Repeat step 1 at desired intervals to determine stability (frequency change).

6.9.7 **Data Reduction.** Calculate local oscillator frequency (input frequency minus output frequency), maximum frequency error (calculated local oscillator frequency minus specified local oscillator frequency), and total local oscillator frequency change (maximum local oscillator frequency minus minimum local oscillator frequency) and record on Data Sheet 6-9.



<p><b>NOTE</b></p> 	<p>This procedure assumes low side local oscillator injection (local oscillator frequency lower than input frequency). If high side injection (local oscillator frequency higher than input frequency) is used, the local oscillator frequency is the <u>sum</u> of the input and output frequencies.</p>
--	---

<b>Data Sheet 6-9. Telemetry Downconverters</b>																															
<b>Test 6.9</b>	<b>Local oscillator frequency accuracy and stability</b>																														
<b>Downconverter Manufacturer:</b>		<b>Model:</b>																													
<b>Serial No.:</b>																															
<b>Test Personnel:</b>	<b>Date:</b>	<b>Location:</b>																													
<b>Specified local oscillator frequency:</b>	<b>MHz</b>																														
<table border="1" style="margin: auto; border-collapse: collapse; width: 80%;"> <thead> <tr> <th colspan="4" style="text-align: center; padding: 5px;">Frequency (MHz)</th> </tr> <tr> <th style="width: 15%; padding: 5px;">Time</th> <th style="width: 20%; padding: 5px;">Input</th> <th style="width: 20%; padding: 5px;">Output</th> <th style="width: 45%; padding: 5px;">Local oscillator</th> </tr> </thead> <tbody> <tr><td style="border-top: 1px solid black; border-bottom: 1px solid black;"> </td><td style="border-top: 1px solid black; border-bottom: 1px solid black;"> </td><td style="border-top: 1px solid black; border-bottom: 1px solid black;"> </td><td style="border-top: 1px solid black; border-bottom: 1px solid black;"> </td></tr> <tr><td style="border-top: 1px solid black; border-bottom: 1px solid black;"> </td><td style="border-top: 1px solid black; border-bottom: 1px solid black;"> </td><td style="border-top: 1px solid black; border-bottom: 1px solid black;"> </td><td style="border-top: 1px solid black; border-bottom: 1px solid black;"> </td></tr> <tr><td style="border-top: 1px solid black; border-bottom: 1px solid black;"> </td><td style="border-top: 1px solid black; border-bottom: 1px solid black;"> </td><td style="border-top: 1px solid black; border-bottom: 1px solid black;"> </td><td style="border-top: 1px solid black; border-bottom: 1px solid black;"> </td></tr> <tr><td style="border-top: 1px solid black; border-bottom: 1px solid black;"> </td><td style="border-top: 1px solid black; border-bottom: 1px solid black;"> </td><td style="border-top: 1px solid black; border-bottom: 1px solid black;"> </td><td style="border-top: 1px solid black; border-bottom: 1px solid black;"> </td></tr> <tr><td style="border-top: 1px solid black; border-bottom: 1px solid black;"> </td><td style="border-top: 1px solid black; border-bottom: 1px solid black;"> </td><td style="border-top: 1px solid black; border-bottom: 1px solid black;"> </td><td style="border-top: 1px solid black; border-bottom: 1px solid black;"> </td></tr> </tbody> </table>				Frequency (MHz)				Time	Input	Output	Local oscillator																				
Frequency (MHz)																															
Time	Input	Output	Local oscillator																												
<p>Maximum local oscillator frequency error: _____ Hz</p> <p>Local oscillator frequency change: _____ Hz</p>																															

## 6.10. TEST: Local Oscillator Radiation at Downconverter Input

6.10.1 Purpose. This test determines if any emissions are appearing at the downconverter input because of radiation from the local oscillator. Radiation from the local oscillator can interfere with other downconverters or TM receivers in the system. This emission interference happens when the signal from one downconverter's local oscillator is fed back into another downconverter's input. This situation is possible when two or more downconverters are driven from a common multicoupler or power splitter having poor output port isolation.

6.10.2 Test Equipment. An RF signal generator, spectrum analyzer, and power meter.

6.10.3 Test Method. A spectrum analyzer is used to scan across the downconverter input frequency band to detect any emissions.

6.10.4 Setup. Connect the test equipment as shown in [Figure 6-11](#).

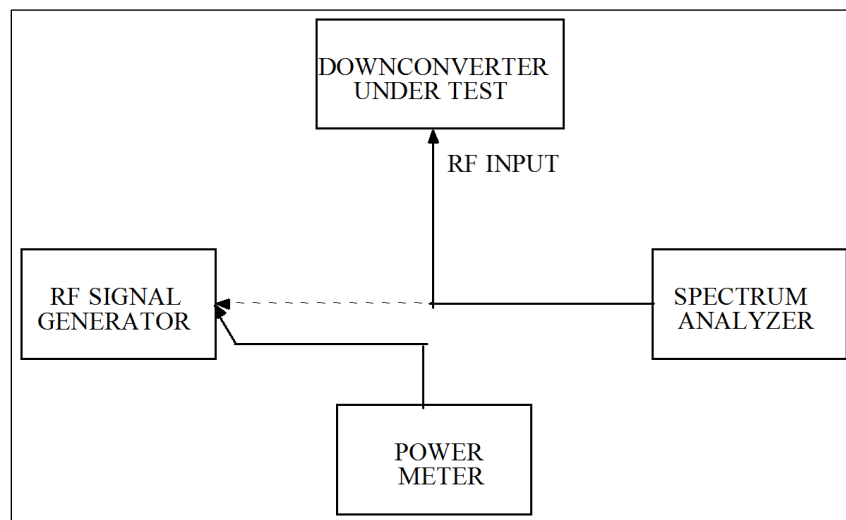

Figure 6-11. Local Oscillator Radiation Test

6.10.5 Conditions. Use double-shielded cable (RG 214 or equivalent) between the spectrum analyzer and the downconverter RF input.

### 6.10.6 Procedure

1. Connect the power meter to the RF signal generator output and adjust the generator frequency to correspond to the downconverter center operating frequency. Adjust the output level to  $-25$  dBm. This signal will be used to calibrate the spectrum analyzer.
2. Disconnect the power meter and connect the RF signal generator to the spectrum analyzer. Adjust the analyzer so that the  $-25$ -dBm input signal to the connecting cable appears as 0 dB on the display unit. The spectrum analyzer can now detect signals as low as  $-85$  dBm. (It is assumed that the spectrum analyzer has a 60-dB dynamic range.) Indicated amplitudes must be corrected by  $-25$  dBm to obtain correct component amplitudes (see Data Sheet 6-10). Calibration of the spectrum analyzer should be checked at each observed frequency.
3. Remove the cable from the RF generator and connect the downconverter RF input to the spectrum analyzer. Tune the spectrum analyzer slowly across the frequency range from 10 MHz to 10 GHz and record the frequency and amplitude of all signals observed.

4. Record measured data on Data Sheet 6-10.

6.10.7 Data Reduction. None

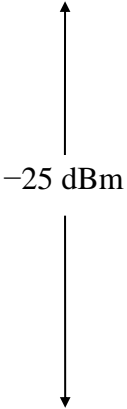
<b>Data Sheet 6-10. Telemetry Downconverters</b>			
<b>Test 6.10</b>	<b>Local oscillator radiation test</b>		
<b>Downconverter Manufacturer:</b>		<b>Model:</b>	
<b>Serial No.:</b>			
<b>Test Personnel:</b>		<b>Date:</b>	<b>Location:</b>
<b>Frequency (MHz)</b>	<b>Indicated Amplitude (dBm)</b>	<b>Calibration Correction</b>	<b>Corrected Amplitude (dBm)</b>
			

This page intentionally left blank.

## CHAPTER 7

### Test Procedures for Telemetry Demodulators

#### 7. General

This chapter provides test procedures for demodulators for the following digital modulation schemes.

- PCM/FM
- Shaped Offset Quadrature Phase Shift Keying, Telemetry Group (SOQPSK-TG)
- Feher-patented Quadrature Phase Shift Keying-B (FQPSK-B)
- FQPSK Jefferis-Rich (FQPSK-JR)
- Advanced Range Telemetry Continuous Phase Modulation (ARTM CPM)

These digital modulation schemes have become standard in most TM systems. The following test procedures are recommended for testing demodulators used for these modulation schemes. [Table 7-1](#) lists the types of tests and their test and paragraph number.

<b>Test Number</b>	<b>Test Description</b>
<a href="#">7.1</a>	Demodulator BEP versus $E_b/N_0$
<a href="#">7.2</a>	Re-acquisition and synchronization loss thresholds
<a href="#">7.3</a>	Bit rate and input frequency tracking
<a href="#">7.4</a>	Demodulator acquisition time and flat fade recovery time
<a href="#">7.5</a>	Demodulator adjacent-channel interference test
<a href="#">7.6</a>	PCM/FM demodulator modulation index sensitivity test

#### 7.1. TEST: Demodulator Bit Error Probability versus $E_b/N_0$

7.1.1 **Purpose.** This test measures the BEP versus  $E_b/N_0$  performance of the demodulator.

7.1.2 **Test Equipment.** Spectrum analyzer, BERT (with outputs matched to signal source inputs), attenuator, waveform signal source, noise test set.

7.1.3 **Setup.** Connect test equipment as shown on [Figure 7-1](#) or [Figure 7-2](#). This paragraph presents a method for finding the attenuation that results in an  $E_b/N_0$  of 15 dB when the attenuator plus receiver combination shown in [Figure 7-2](#) is used.

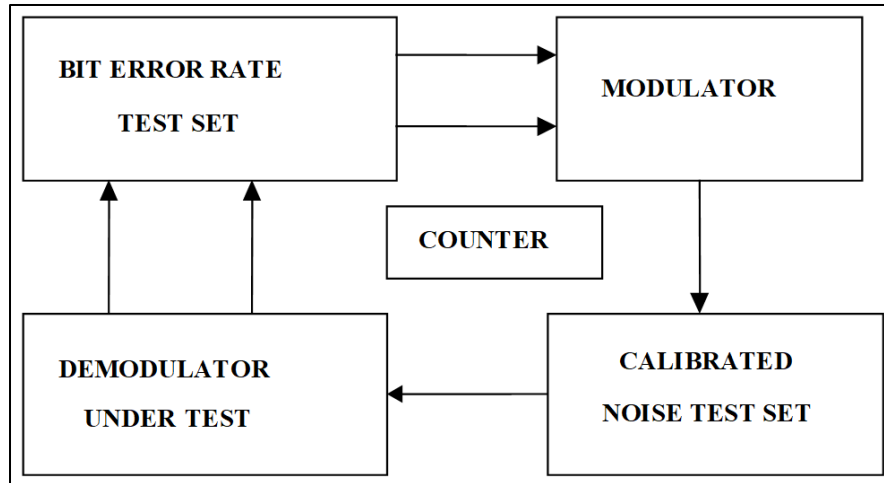

Figure 7-1. Test Setup for Demodulator BEP Tests

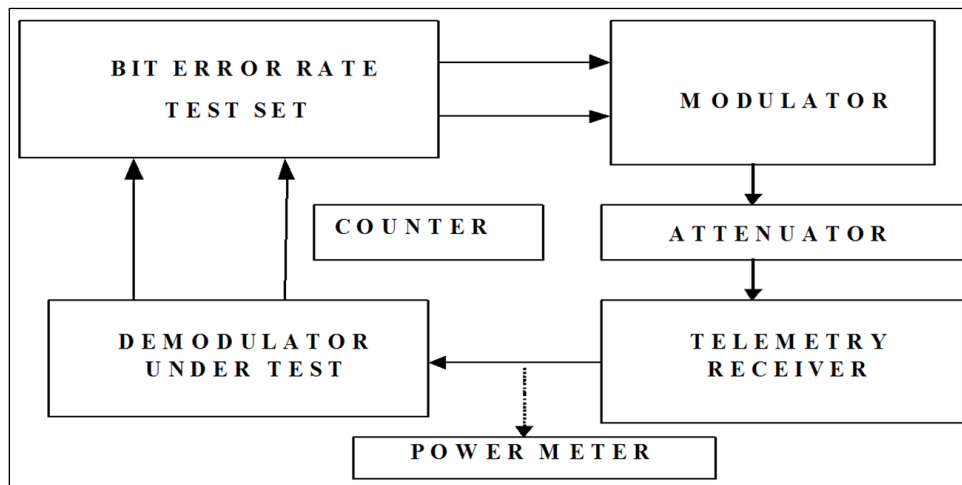

Figure 7-2. Alternate Setup for Demodulator BEP Test

1. First, apply a “101010” repeating pattern to the modulator. This pattern should produce an unmodulated carrier signal. If not, verify that the modulator is properly differentially encoding the data source. Turn off the source and set the attenuation to the maximum value. Use AGC freeze or manual gain to set the noise power at the receiver IF output in the linear region. Measure the power level.
2. Turn on the source and decrease the attenuation until the power level at the IF output increases by 3 dB. This value is the 0-dB IF carrier-to-noise ratio and the  $E_b/N_0$  is  $10\log(\text{IF bandwidth/bit rate})$ . Put the receiver in AGC mode and decrease the attenuation by approximately  $15 - 10\log(\text{IF bandwidth/bit rate})$ . Use AGC freeze or manual gain to set the noise power at the receiver IF output in the linear region. Measure the power level (S+N) in watts.
3. Turn off the source and set the attenuation to the maximum value. Measure the power level (N) in watts. Calculate the  $E_b/N_0$  from  $10\log(((S+N)-N)/N)+10\log(\text{IF bandwidth/bit rate})$ . The most accurate value to use for IF bandwidth is the equivalent noise power bandwidth but, if the  $-3\text{-dB}$  bandwidth (either measured or specified) is the only value readily available,



it will give nearly the same value for  $E_b/N_0$ . If the measured value is not within 0.5 dB of 15 dB, change the attenuation by the appropriate amount to get within 0.5 dB of 15 dB and repeat the (S+N) and (N) measurements and calculations. The  $E_b/N_0$  is now calibrated and will change by 1 dB for each 1 dB of attenuation change.

7.1.4 Conditions. This test can be performed using a waveform signal source at the demodulator input frequency plus a noise test set that generates the selected  $E_b/N_0$ ; a waveform signal source plus noise test set at a higher frequency that generates the selected  $E_b/N_0$  followed by downconversion to the demodulator input frequency; or a waveform signal source followed by an attenuator and a TM receiver that are then calibrated in terms of  $E_b/N_0$ . The signal should be non-linearly amplified to better reflect a typical TM transmitter.

#### 7.1.5 Procedure

1. Set the BERT to generate the desired bit rate with a pseudo noise sequence length of at least  $2^{11}-1$  (2047) bits and preferably at least  $2^{20}-1$  bits long (the longer sequence is a better simulation of the characteristics of an encrypted signal). Set the signal source to generate a non-linearly amplified signal. Use the spectrum analyzer to verify the signal spectrum looks like the expected (PCM/FM, SOQPSK-TG/ /FQPSK-JR, ARTM CPM) spectrum.
2. Set the initial  $E_b/N_0$  to approximately 15 dB and verify that the BERT synchronizes in the non-inverted state. If the BERT does not synchronize, invert the output polarity of the demodulator. If the BERT now synchronizes, there is a polarity inversion somewhere. The source polarity can be checked by applying all zeroes (which can frequently be done by terminating the data input to the modulator) and verifying that the output is an unmodulated signal with a frequency equal to center frequency minus (bit rate)/4. If the output is an unmodulated signal with a frequency equal to center frequency plus bit rate/4 then the modulator is inverted. If the modulator polarity is not inverted but the demodulator polarity is inverted, then the inversion is in the demodulator
3. Set the initial  $E_b/N_0$  to approximately 15 dB and measure the bit errors in an interval of  $10^7$  or  $10^8$  bits. If the BER is larger than 1 per  $10^6$  bits, increase the  $E_b/N_0$  until the error rate is less than 1 error per  $10^6$  bits and record the  $E_b/N_0$  as the starting value on the data sheet. Measure the BEP in 1-dB intervals (reduce the  $E_b/N_0$  by 1 dB for each step) and record the  $E_b/N_0$  and BEP on Data Sheet 7-1. If more than 1000 errors occur in an interval, the measurement time can be reduced by a factor of 10 without significantly degrading accuracy.
4. Repeat for other bit rates as desired.

7.1.6 Data Reduction. Compare the measured BEP versus  $E_b/N_0$  with the specification. Plot the data and interpolate between points to estimate the BEP at a given  $E_b/N_0$  or to find the  $E_b/N_0$  that is required for a given BEP.

<b>Data Sheet 7-1. Demodulators</b>																																											
<b>Test 7.1</b>	<b>Bit error probability versus <math>E_b/N_0</math></b>																																										
<b>Manufacturer:</b>	<b>Model:</b>																																										
<b>Serial No.:</b>																																											
<b>Test Personnel:</b>	<b>Date:</b>																																										
Center frequency: _____ MHz																																											
Data and clock interface: <input type="checkbox"/> TTL <input type="checkbox"/> ECL <input type="checkbox"/> Other _____																																											
(Check a box or write in type)																																											
Bit rate tested: _____ Mbps																																											
<table border="1" style="margin: auto; border-collapse: collapse;"> <thead> <tr> <th style="width: 50%; padding: 5px;"><math>E_b/N_0</math></th> <th style="width: 50%; padding: 5px;">Bit Error Probability</th> </tr> </thead> <tbody> <tr><td> </td><td> </td></tr> <tr><td> </td><td> </td></tr> <tr><td> </td><td> </td></tr> <tr><td> </td><td> </td></tr> <tr><td> </td><td> </td></tr> <tr><td> </td><td> </td></tr> <tr><td> </td><td> </td></tr> <tr><td> </td><td> </td></tr> <tr><td> </td><td> </td></tr> <tr><td> </td><td> </td></tr> <tr><td> </td><td> </td></tr> <tr><td> </td><td> </td></tr> <tr><td> </td><td> </td></tr> <tr><td> </td><td> </td></tr> <tr><td> </td><td> </td></tr> <tr><td> </td><td> </td></tr> <tr><td> </td><td> </td></tr> <tr><td> </td><td> </td></tr> <tr><td> </td><td> </td></tr> <tr><td> </td><td> </td></tr> </tbody> </table>		$E_b/N_0$	Bit Error Probability																																								
$E_b/N_0$	Bit Error Probability																																										

## 7.2. TEST: Reacquisition and Synchronization Loss Thresholds

7.2.1 Purpose. This test measures the minimum  $E_b/N_0$  that results in consistent acquisition (defined as typically back in synchronization in a few seconds) and the  $E_b/N_0$  at which synchronization starts to be lost.

7.2.2 Test Equipment. Spectrum analyzer, BERT (with outputs matched to the signal source inputs, i.e., TTL, ECL), attenuator, signal source, noise source.

7.2.3 Setup. Connect test equipment as shown on [Figure 7-1](#) or [Figure 7-2](#), depending on the test equipment available.

7.2.4 Conditions. This test can be performed using a signal source at the demodulator input frequency plus a calibrated noise test set that generates the selected  $E_b/N_0$ ; a signal source plus noise test set at a higher frequency that generates the selected  $E_b/N_0$  followed by downconversion to the demodulator input frequency; or a signal source followed by an attenuator and a TM receiver that are then calibrated in terms of  $E_b/N_0$ .

### 7.2.5 Procedure

1. Set the BERT to generate the desired bit rate with a pseudo noise sequence length of at least 2047 bits and preferably at least  $2^{20}-1$  bits long. Set the signal source to generate a non-linearly amplified signal with the correct modulation scheme. Verify the signal spectrum using the spectrum analyzer.
2. Set the initial  $E_b/N_0$  to 10 dB and decrease the  $E_b/N_0$  in 1-dB steps (0.1-dB steps are optional in the region of synchronization loss) until the BERT starts to lose synchronization. Record the lowest value of  $E_b/N_0$  with solid synchronization on Data Sheet 7-2.
3. Set the  $E_b/N_0$  to the lowest value at which solid synchronization was maintained. Turn off the signal source (or insert maximum attenuation). Turn the signal back on at the  $E_b/N_0$  set above. If the signal is reacquired rapidly, then record this  $E_b/N_0$  on Data Sheet 7-2. If the signal is not rapidly reacquired, repeat the process with the  $E_b/N_0$  increased in 1-dB steps (0.1-dB steps are optional in the region of synchronization recovery) until rapid resynchronization occurs.
4. Repeat for other bit rates as desired.

7.2.6 Data Reduction. Compare the measured  $E_b/N_0$  values with the specification.

<b>Data Sheet 7-2. Demodulators</b>																			
<b>Test 7.2</b>	<b>Acquisition and synchronization loss thresholds versus <math>E_b/N_0</math></b>																		
<b>Manufacturer:</b>	<b>Model:</b>																		
<b>Serial No.:</b>																			
<b>Test Personnel:</b>	<b>Date:</b>																		
<p>Center frequency: _____ MHz</p> <p>Data and clock interface: _____</p> <p>Bit rate tested: _____ Mbps</p>																			
<table border="1" style="margin: auto; border-collapse: collapse;"> <thead> <tr> <th style="width: 70%;"></th> <th style="width: 30%; text-align: center;"><math>E_b/N_0</math></th> </tr> </thead> <tbody> <tr> <td>Synchronization loss threshold:</td> <td></td> </tr> <tr> <td>Re-acquisition threshold:</td> <td></td> </tr> <tr> <td> </td> <td></td> </tr> <tr> <td> </td> <td></td> </tr> <tr> <td> </td> <td></td> </tr> <tr> <td> </td> <td></td> </tr> <tr> <td> </td> <td></td> </tr> <tr> <td> </td> <td></td> </tr> </tbody> </table>			$E_b/N_0$	Synchronization loss threshold:		Re-acquisition threshold:													
	$E_b/N_0$																		
Synchronization loss threshold:																			
Re-acquisition threshold:																			

### 7.3. TEST: Bit Rate and Input Frequency Tracking

7.3.1 Purpose. This test measures the maximum carrier and bit rate errors that allow consistent acquisition (defined as typically back in synchronization in a few seconds) and tracking.

7.3.2 Test Equipment. Spectrum analyzer, BERT (with outputs matched to signal source inputs, i.e., TTL, ECL, etc.), attenuator, signal source, noise source, counter.

7.3.3 Setup. Connect test equipment as shown on [Figure 7-1](#) or [Figure 7-2](#) depending on the test equipment available.

7.3.4 Conditions. This test can be performed using a signal source at the demodulator input frequency plus a noise test set that generates the selected  $E_b/N_0$ ; a signal source plus noise test set at a higher frequency that generates the selected  $E_b/N_0$  followed by downconversion to the demodulator input frequency; or a signal source followed by an attenuator and a TM receiver that are then calibrated in terms of  $E_b/N_0$ . The test equipment must be able to set the demodulator input frequency and bit rate to the required precision.

#### 7.3.5 Procedure

1. Set the BERT to generate the desired bit rate with a pseudo noise sequence length of at least 2047 bits and preferably at least  $2^{20}-1$  bits long. Set the signal source to generate the proper non-linearly amplified signal. Verify the signal spectrum using the spectrum analyzer.
2. Set the  $E_b/N_0$  to 10 dB and monitor the BEP. Decrease the source bit rate (don't change bit rate set on demodulator) until the BEP increases by a factor of 2, or the BERT starts to lose synchronization, whichever occurs first. Count the source clock frequency and record the value on Data Sheet 7-3 as the lower frequency bit rate. Set the bit rate of the source to the nominal value. Increase the bit rate until the BEP increases by a factor of 2, or the BERT starts to lose synchronization, whichever occurs first. Count the source clock frequency, and record the value on Data Sheet 7-3 as the upper frequency bit rate. Repeat for other bit rates as desired.
3. Set the  $E_b/N_0$  to 10 dB and monitor the BEP. Decrease the demodulator input frequency (preferably by changing the frequency of the RF source) until the BEP increases by a factor of 2, or the BERT starts to lose synchronization, whichever occurs first. Count the demodulator input frequency and record the value on Data Sheet 7-3 as the lower frequency input. Increase the demodulator input frequency until the BEP increases by a factor of 2, or the BERT starts to lose synchronization, whichever occurs first. Count the demodulator input frequency, and record the value on Data Sheet 7-3 as the upper frequency input. Repeat for other bit rates as desired.

7.3.6 Data Reduction. Compare the measured values with the specification.

<b>Data Sheet 7-3. Demodulators</b>																												
<b>Test 7.3</b>	<b>Bit rate and input frequency tracking</b>																											
<b>Manufacturer:</b>	<b>Model:</b>																											
<b>Serial No.:</b>																												
<b>Test Personnel:</b>	<b>Date:</b>																											
<p>Data and clock interface: _____</p> <p>Center frequency: _____ MHz</p> <p>Bit rate: _____ Mbps</p> <table border="1" style="margin-left: auto; margin-right: auto; border-collapse: collapse; width: 60%;"> <thead> <tr> <th style="width: 30%;"></th> <th style="width: 35%; text-align: center;">Bit rate (Mbps)</th> <th style="width: 35%; text-align: center;">Input Frequency (MHz)</th> </tr> </thead> <tbody> <tr> <td style="text-align: center;">Lower frequency</td> <td></td> <td></td> </tr> <tr> <td style="text-align: center;">Higher frequency</td> <td></td> <td></td> </tr> </tbody> </table> <p>Center frequency: _____ MHz</p> <p>Bit rate: _____ Mbps</p> <table border="1" style="margin-left: auto; margin-right: auto; border-collapse: collapse; width: 60%;"> <thead> <tr> <th style="width: 30%;"></th> <th style="width: 35%; text-align: center;">Bit rate (Mbps)</th> <th style="width: 35%; text-align: center;">Input Frequency (MHz)</th> </tr> </thead> <tbody> <tr> <td style="text-align: center;">Lower frequency</td> <td></td> <td></td> </tr> <tr> <td style="text-align: center;">Higher frequency</td> <td></td> <td></td> </tr> </tbody> </table> <p>Center frequency: _____ MHz</p> <p>Bit rate: _____ Mbps</p> <table border="1" style="margin-left: auto; margin-right: auto; border-collapse: collapse; width: 60%;"> <thead> <tr> <th style="width: 30%;"></th> <th style="width: 35%; text-align: center;">Bit rate (Mbps)</th> <th style="width: 35%; text-align: center;">Input Frequency (MHz)</th> </tr> </thead> <tbody> <tr> <td style="text-align: center;">Lower frequency</td> <td></td> <td></td> </tr> <tr> <td style="text-align: center;">Higher frequency</td> <td></td> <td></td> </tr> </tbody> </table>			Bit rate (Mbps)	Input Frequency (MHz)	Lower frequency			Higher frequency				Bit rate (Mbps)	Input Frequency (MHz)	Lower frequency			Higher frequency				Bit rate (Mbps)	Input Frequency (MHz)	Lower frequency			Higher frequency		
	Bit rate (Mbps)	Input Frequency (MHz)																										
Lower frequency																												
Higher frequency																												
	Bit rate (Mbps)	Input Frequency (MHz)																										
Lower frequency																												
Higher frequency																												
	Bit rate (Mbps)	Input Frequency (MHz)																										
Lower frequency																												
Higher frequency																												

#### 7.4. TEST: Demodulator Acquisition Time and Flat Fade Recovery Time.

7.4.1 Purpose. This test measures the time it takes for the demodulator to synchronize with the input sweeping carrier frequency and symbol rates after a fairly long interval of no acceptable input. The purpose of the flat fade recovery time test is to measure the time it takes for the demodulator to synchronize with the sweeping input carrier and symbol rates after a fairly short interval of no discernable input.

7.4.2 Test Equipment. Spectrum analyzer, BERT (with outputs matched to signal source inputs, i.e., TTL, ECL, if required), attenuator, signal source, noise source, digital oscilloscope, and switch.

7.4.3 Setup. Connect test equipment as shown on [Figure 7-3](#).

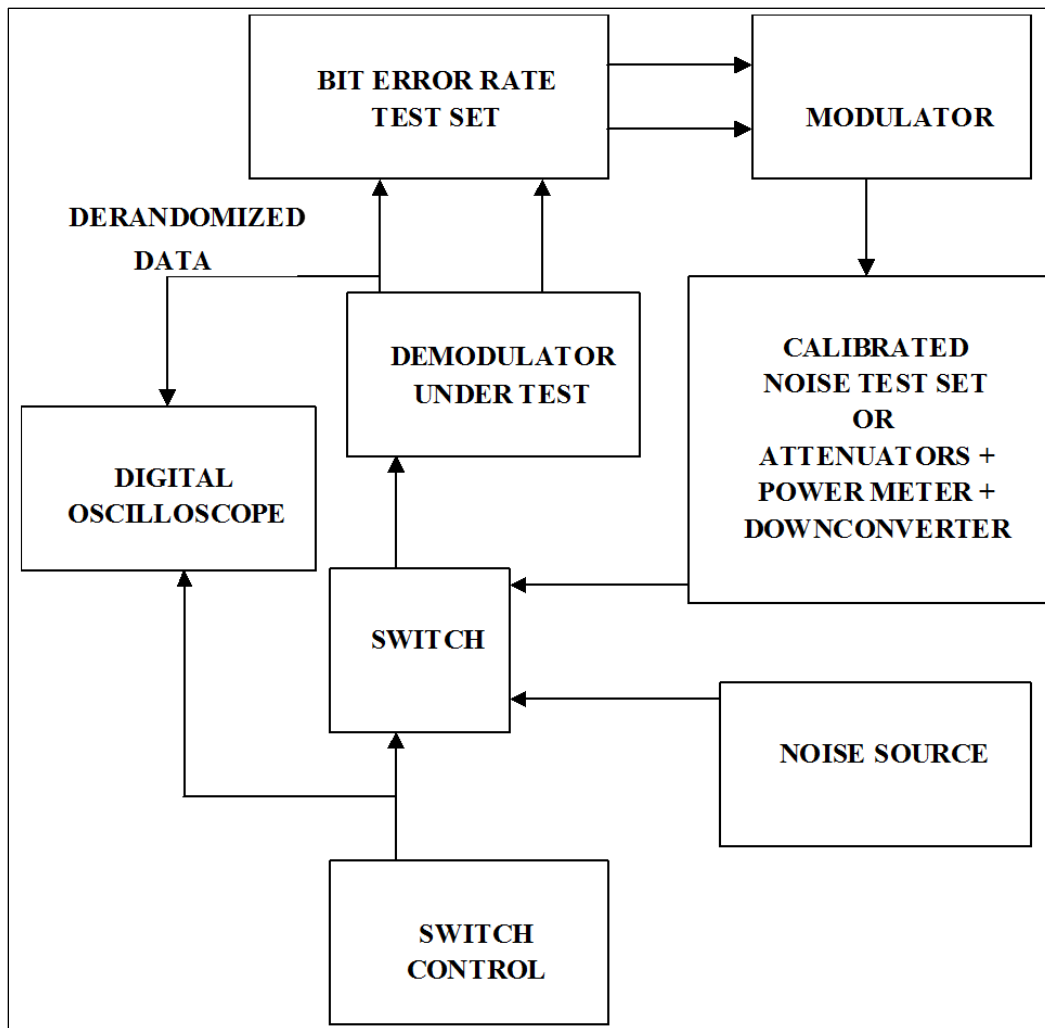

Figure 7-3. Test Setup for Demodulator Acquisition Time and Flat Fade Recovery Tests

7.4.4 Conditions. This test can be performed using a signal source at the demodulator input frequency plus a noise test set that generates the selected  $E_b/N_0$ ; a signal source plus noise test set at a higher frequency that generates the selected  $E_b/N_0$  followed by downconversion to the demodulator input frequency; or a signal source followed by an attenuator and a TM receiver

that are then calibrated in terms of  $E_b/N_0$ . The power level of the noise source should be set to approximate the level of the TM signal in the bandwidth of interest (a receiver in MGC mode with no input would be a good choice for this noise source). If the BERT has the capability of measuring acquisition time, it may be used in place of the digital oscilloscope. In all conditions, the signal source should have the capability to sweep the carrier frequency at least  $\pm 100$  kHz with a ramp-up/ramp-down profile.

#### 7.4.5 Procedure

1. Set the BERT to generate the desired bit rate with a pseudo noise sequence length of  $2^{15}-1$  bits with the sequence generated using feedback from register taps 14 and 15. A  $2^{15}-1$  bit maximal length sequence is used for this test because it is compatible with the IRIG 15 stage de-randomizer. One could also randomize an all ones or all zeros signal to get a good test signal. A randomized sequence of ones should produce ones at the de-randomizer output and randomized zeroes should produce zeroes (non-inverting mode assumed). Set the signal source to generate the required non-linearly amplified TM signal. Verify the signal spectrum using the spectrum analyzer. Set the demodulator to de-randomize the input signal. The de-randomized output should be all zeroes, if there are no bit errors. Any bit errors will show up as ones in the de-randomized output. Some demodulators output the zero state when the demodulator is out of synchronization. In this case, it may be preferable to invert the data output to more easily determine the error-free state from the out-of-synchronization state. If the output is inverted, errors show up as the zero state at the de-randomized output.
2. Set the input frequency and bit rate to the nominal values selected on the demodulator. Set the initial  $E_b/N_0$  to 15 dB. Set the switch to pass the signal for about 2 seconds and the noise signal for about 8 seconds in a pattern that repeats every 10 seconds. Trigger the digital oscilloscope on the transition to the signal and record intervals of about 500 ms (this value may need to be varied to capture the actual acquisition times with sufficient accuracy). Set the signal source to sweep the carrier frequency  $\pm 100$  kHz, or to a range compatible with the capture range of the demodulator. The acquisition time is the time at which the output data is stable in the all zeroes state. Repeat the test 10 times and record the acquisition times on Data Sheet 7-4.
3. Repeat step 2 for various combinations of input frequency sweep range, bit rate offset, and  $E_b/N_0$ .
4. Change the switch control to 1500 ms and 500 ms in noise mode (flat fade recovery or reacquisition nominal test conditions). Repeat steps 2 and 3 for the desired combinations of input frequency sweep range, bit rate offset, and  $E_b/N_0$ .
5. Repeat steps 2 through 4 for various bit rates and switch on/off times, as desired.

7.4.6 Data Reduction. Compare the measured acquisition and reacquisition times with the values in the specification.



Data Sheet 7-4. Demodulators																																																																	
<b>Test 7.4</b>	<b>Demodulator acquisition time and flat fade recovery time</b>																																																																
<b>Manufacturer:</b>	<b>Model:</b>																																																																
<b>Serial No.:</b>																																																																	
<b>Test Personnel:</b>	<b>Date:</b>																																																																
Center frequency: _____ MHz Data and clock interface: _____ Bit rate tested: _____ Mbps Carrier sweep range _____ kHz Switch on-time (modulator position) _____ seconds Switch off-time (noise position): _____ seconds																																																																	
<table border="1" style="width: 100%; border-collapse: collapse; text-align: center;"> <thead> <tr> <th style="padding: 5px;">Frequency (MHz)</th> <th style="padding: 5px;">Bit Rate (Mbps)</th> <th style="padding: 5px;"><math>E_b/N_0</math> (dB)</th> <th style="padding: 5px;">Acquisition Time (ms)</th> </tr> </thead> <tbody> <tr><td> </td><td> </td><td> </td><td> </td></tr> <tr><td> </td><td> </td><td> </td><td> </td></tr> <tr><td> </td><td> </td><td> </td><td> </td></tr> <tr><td> </td><td> </td><td> </td><td> </td></tr> <tr><td> </td><td> </td><td> </td><td> </td></tr> <tr><td> </td><td> </td><td> </td><td> </td></tr> <tr><td> </td><td> </td><td> </td><td> </td></tr> <tr><td> </td><td> </td><td> </td><td> </td></tr> <tr><td> </td><td> </td><td> </td><td> </td></tr> <tr><td> </td><td> </td><td> </td><td> </td></tr> <tr><td> </td><td> </td><td> </td><td> </td></tr> <tr><td> </td><td> </td><td> </td><td> </td></tr> <tr><td> </td><td> </td><td> </td><td> </td></tr> <tr><td> </td><td> </td><td> </td><td> </td></tr> <tr><td> </td><td> </td><td> </td><td> </td></tr> </tbody> </table>		Frequency (MHz)	Bit Rate (Mbps)	$E_b/N_0$ (dB)	Acquisition Time (ms)																																																												
Frequency (MHz)	Bit Rate (Mbps)	$E_b/N_0$ (dB)	Acquisition Time (ms)																																																														

## 7.5. TEST: Demodulator Adjacent Channel Interference Test

7.5.1 **Purpose.** This test measures the effect on BEP of signals in adjacent frequency channels. The results will be a function of modulation methods, receiver filter characteristics, bit rates, relative power levels, frequency spacing, and demodulator characteristics.

7.5.2 **Test Equipment.** Spectrum analyzer, BERT (with outputs matched to the signal source inputs, i.e., TTL, ECL, if required), attenuators, TM signal sources, noise source, power splitters, power meter, (a specialized test set can replace most of this test equipment if one is available), and other RF sources as needed (for example, if FM interfering signals will be tested, then FM signal sources with appropriate premodulation filtering will be needed).

7.5.3 **Setup.** Connect test equipment as shown in [Figure 7-4](#).

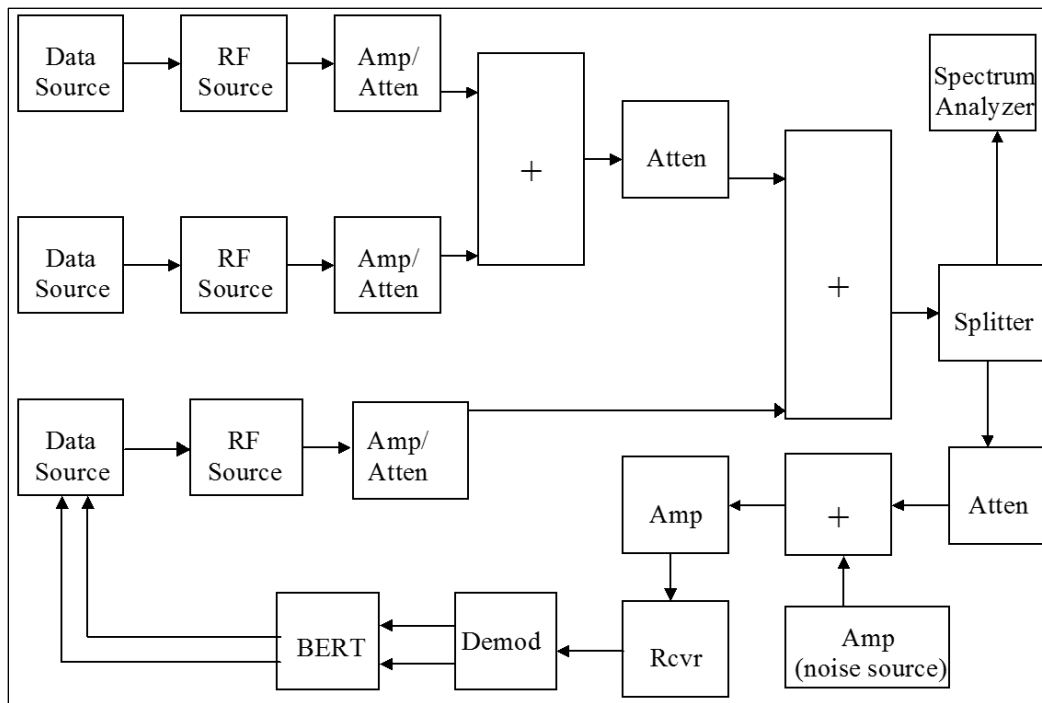

Figure 7-4. Test Setup for Adjacent Channel Interference Test

7.5.4 **Conditions.** This test can be performed using various modulation types as the interferers. The test can also be performed with only one interferer or with two interferers (one above and one below the victim signal). This test can be performed with actual TM transmitters or with appropriate laboratory signal generators. The laboratory generators should be passed through an amplifier of the same type as will be used in the actual transmitters (an amplifier operating in its non-linear range can be used if an amplifier of the proper type is not available.) If the purpose of the test is to evaluate performance during a test mission with a specific set of frequencies, bit rates, and modulation types, use these parameters for the test.

### 7.5.5 Procedure

1. Set the BERT to generate the desired bit rate with a pseudo noise sequence length of at least  $2^{11}-1$  bits. Use this BERT as the input to the TM signal modulator (this signal will be the center signal and called the victim). The modulator output will typically need to be non-

linearly amplified to simulate a typical TM transmitter. Similarly, modulate the other two RF sources with independent pseudo noise sequences at the same bit rate and non-linearly amplify the outputs. Set the frequencies of these signals to frequencies equal to the bit rate above and below the frequency of the victim signal.

2. Apply maximum attenuation to the two interferers to effectively remove them from the output (at least 30 dB below desired signal power). Set the attenuators and noise source level to produce a BEP of  $10^{-5}$ . Increase the level of the victim signal by 1 dB.
3. Use the spectrum analyzer (or alternatively a power meter) to set the relative powers of the signals. A typical starting point is to have the two interfering signals 20 dB larger than the victim signal. Vary the attenuator that is common to the two interferers until the BEP is again  $10^{-5}$ . Measure the relative power levels of the victim and interferers and record on Data Sheet 7-5.
4. Repeat steps 3 and 4 for various bit rates, modulation types of interferers, center frequencies, and frequency separations, as desired.

7.5.6 Data Reduction. Subtract the victim power level from the interferer power level and record on Data Sheet 7-5.

<b>Data Sheet 7-5. Demodulators</b>			
<b>Test 7.5</b>	<b>Adjacent channel interference</b>		
<b>Manufacturer:</b>		<b>Model:</b>	
<b>Serial No.:</b>			
<b>Test Personnel:</b>		<b>Date:</b>	
Receiver IF Bandwidth _____ MHz			
Victim: Frequency _____ MHz      Bit rate _____ Mbps      Modulation type _____			
Peak deviation _____      Filter BW _____ MHz      Power _____ dBm			
Interferer 1: Frequency _____ MHz      Bit rate _____ Mbps      Modulation type _____			
Peak deviation _____      Filter BW _____ MHz      Power _____ dBm			
Interferer 2: Frequency _____ MHz      Bit rate _____ Mbps      Modulation type _____			
Peak deviation _____      Filter BW _____ MHz      Power _____ dBm			
<b>Power level difference between Victim and Interferers _____ dB</b>			
Receiver IF Bandwidth _____ MHz			
Victim: Frequency _____ MHz      Bit rate _____ Mbps      Modulation type _____			
Peak deviation _____      Filter BW _____ MHz      Power _____ dBm			
Interferer 1: Frequency _____ MHz      Bit rate _____ Mbps      Modulation type _____			
Peak deviation _____      Filter BW _____ MHz      Power _____ dBm			
Interferer 2: Frequency _____ MHz      Bit rate _____ Mbps      Modulation type _____			
Peak deviation _____      Filter BW _____ MHz      Power _____ dBm			
<b>Power level difference between Victim and Interferers _____ dB</b>			
Receiver IF Bandwidth _____ MHz			
Victim: Frequency _____ MHz      Bit rate _____ Mbps      Modulation type _____			
Peak deviation _____      Filter BW _____ MHz      Power _____ dBm			
Interferer : 1 Frequency _____ MHz      Bit rate _____ Mbps      Modulation type _____			
Peak deviation _____      Filter BW _____ MHz      Power _____ dBm			
Interferer 2: Frequency _____ MHz      Bit rate _____ Mbps      Modulation type _____			
Peak deviation _____      Filter BW _____ MHz      Power _____ dBm			
<b>Power level difference between Victim and Interferers _____ dB</b>			

## 7.6. TEST: PCM/FM Demodulator Modulation Index Sensitivity Test

7.6.1 Purpose. This test measures the demodulator sensitivity to changes in the modulation index of the source PCM/FM signal.

7.6.2 Test Equipment. Spectrum analyzer, BERT, PCM/FM signal source, directional coupler.

7.6.3 Setup. Connect the test equipment as shown in [Figure 7-5](#). Verify the input level into the demodulator is within the linear operating range of the demodulator.

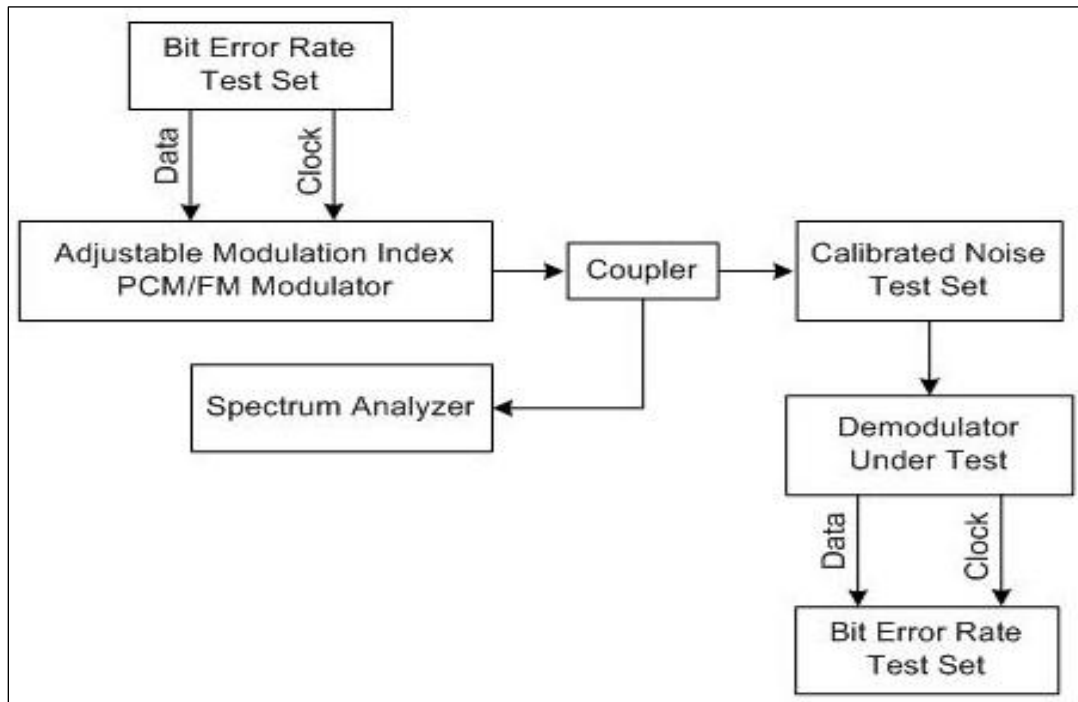

Figure 7-5. Test Setup for Modulation Index Sensitivity Test

7.6.4 Conditions. This test must use a PCM/FM modulator that can control the modulation index. This index must be verified utilizing the spectrum analyzer and the equation called out in the Telemetry Applications Handbook.

### 7.6.5 Procedure

1. Set the BERT to generate the desired bit rate with a pseudo noise sequence of at least  $2^{11}-1$  (2047) bits and preferably at least  $2^{20}-1$  bits long (the longer sequence is a better simulation of the characteristics of an encrypted signal). Set the signal source to generate PCM/FM with a modulation index of 0.7. Use the spectrum analyzer to verify the signal spectrum looks like a PCM/FM spectrum and verify the modulation index is 0.7, which is equal to peak deviation of  $0.35 * (\text{bit rate})$ .
2. Perform a BEP versus  $E_b/N_0$  test as described in Subsection [7.1.5](#) with the modulation index set at 0.7. This curve will be the baseline curve in which to compare the results.
3. Repeat the BEP versus  $E_b/N_0$  test with modulation indices between 0.6 and 0.8.

4. Repeat test for other bit rates desired.

7.6.6 Data Reduction. Compare the BEP versus  $E_b/N_0$  curve with a modulation index of 0.7 with curves at other modulation indices. Plot the data and interpolate between points to estimate the BEP at a given  $E_b/N_0$  or to find the  $E_b/N_0$  that is required for a given BEP.



This page intentionally left blank.



## CHAPTER 8

### Test Procedures for Hardware Implementing Low-Density Parity-Check Codes

#### 8. General

The RCC, beginning with the release of 106-17 Appendix 2D<sup>6</sup>, has adopted low-density parity-check (LDPC) forward error correction code for TM hardware. The Telemetry Group recommends the following procedures for testing TM systems that implement the encoding and decoding of this forward error correction scheme. [Table 8-1](#) lists the types of tests and their test and paragraph number.

<b>Table 8-1. Test Matrix for LDPC-Enabled TM Hardware</b>	
<b>Test Number</b>	<b>Test Description</b>
<a href="#">8.1</a>	Receiver/Decoder BEP versus $E_b/N_0$
<a href="#">8.2</a>	Receiver/Decoder Threshold
<a href="#">8.3</a>	Receiver/Decoder Initial Acquisition and Flat Fade Recovery Times
<a href="#">8.4</a>	Receiver/Decoder Latency Time
<a href="#">8.5</a>	Receiver/Decoder Adjacent Channel Interference
<a href="#">8.6</a>	Transmitter/Encoder 99% Occupied Bandwidth and $-25$ -dBm Bandwidth
<a href="#">8.7</a>	Transmitter/Encoder Spectral Mask Compliance
<a href="#">8.8</a>	Transmitter/Encoder to Receiver/Decoder Interoperability

#### 8.1. TEST: Receiver/Decoder BEP versus $E_b/N_0$

8.1.1 Purpose. This test measures the BEP versus  $E_b/N_0$  performance of the receiver/decoder.

8.1.2 Test Equipment. Various methods are available for performing this test, which include using a simple step attenuator/power meter to determine and set  $E_b/N_0$ , a noise test set that allows direct control of  $E_b/N_0$ , and a receiver analyzer manufactured specifically to perform this test (along with other test methods in addition to BEP versus  $E_b/N_0$ ).

- Step attenuator/power meter method: Modulator with LDPC encoding (e.g. TM transmitter, BERT, in-phase and quadrature [I/Q] signal source, etc.), power meter, step attenuator (in 0.1-dB steps), spectrum analyzer (optional)
- Noise test set method: Modulator with LDPC encoding (e.g. TM transmitter, I/Q signal source, etc.), BERT, noise test set, spectrum analyzer (optional)
- Receiver analyzer method: Receiver analyzer, BERT (if required), spectrum analyzer (optional)

<sup>6</sup> Range Commanders Council. “Low-Density Parity-Check Codes for Telemetry Systems.” Appendix 2D in *Telemetry Standards*. RCC 106-17. July 2017. Superseded by RCC 106-22. Retrieved 13 May 2022. Available at <https://www.trmc.osd.mil/wiki/x/EIu8Bg>.

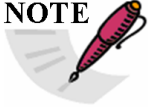
 <p><b>NOTE</b></p>	<p>It is important to use a BERT that can measure error rates up to 50% so that sync failure will be accurately reflected in the BEP curves. Any perturbation or unexpected degradation in the curve at higher BEPs, where the curve is typically smooth and predictable, should be noted as probable synchronization failures. These failures define the lower limit of operation in systems that are intolerant of burst errors in the downstream processing.</p>
--	---

8.1.3 Setup (step attenuator/power meter method). This method is for finding the attenuation that results in an  $E_b/N_0$  of 10 dB when the step attenuator/power meter method shown in [Figure 8-1](#) is used. Care should be taken when making these measurements due to the slope of the LDPC detection curve and required granularity of  $E_b/N_0$ . Each measurement should be stable and repeatable to no more than 0.05 dB.

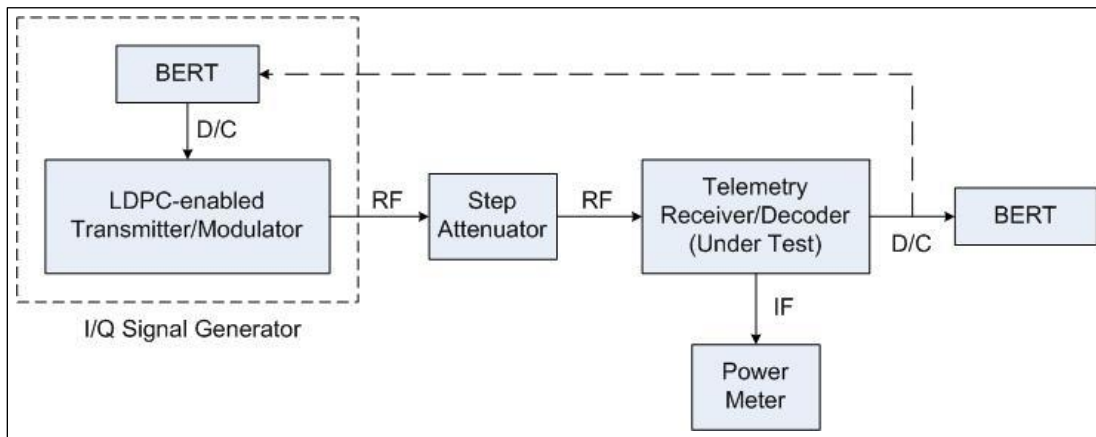

Figure 8-1. Setup for Step Attenuator/Power Meter BEP Test

1. Place the signal source in carrier-only mode. There are several ways of doing this depending upon the specific modulator and modulation scheme being used. (For example, when in SOQPSK-TG/FQPSK-B/FQPSK-JR mode, apply a “101010” repeating pattern to the modulator. This pattern should produce an unmodulated carrier signal.) Turn off the source and set the attenuation to the maximum value. Use AGC freeze or manual gain to set the noise power at the receiver IF output in the linear region. Measure and note the IF power level in watts.
2. Turn on the source and decrease the attenuation until the power level at the IF output increases by 3 dB over the value recorded in step 1. Note this attenuation setting as it will be the baseline to work from. This value is the 0-dB IF carrier-to-noise ratio ( $C/N=0$  dB) thus the  $E_b/N_0$  is given by:

$$\frac{E_b}{N_0} (dB) = 10 \log \left( \frac{IF BW}{Bit Rate} \right) \quad (\text{Eq. 8-1})$$

3. Put the receiver in AGC mode and decrease the attenuation by approximately:

$$10dB - 10 \log \left( \frac{IF BW}{Bit Rate} \right) \quad (\text{Eq. 8-2})$$

4. Use AGC freeze or manual gain to set the noise power at the receiver IF output in the linear region. Measure and note the IF power level in watts. This will be the carrier plus noise

(C+N) value. Note: The bit rate used in the equations is the uncoded bit rate. Units of IF bandwidth and bit rate should be the same.

- Turn off the source and set the attenuation to the maximum value. Measure the noise power level (N) in watts. Calculate the  $E_b/N_0$ :

$$\frac{E_b}{N_0} (dB) = 10 \log \left( \frac{(C+N)-N}{N} \right) + 10 \log \left( \frac{IF BW}{Bit Rate} \right) \quad (\text{Eq. 8-3})$$

The most-accurate value to use for IF bandwidth is the equivalent noise power bandwidth. If the -3-dB bandwidth (either measured or specified) is the only value readily available, it will give nearly the same value for  $E_b/N_0$ . If the measured value is not within 0.1 dB of 10 dB, change the attenuation by the appropriate amount to get within 0.1 dB of 10 dB and repeat the (C+N) and (N) measurements and calculations. The  $E_b/N_0$  is now calibrated and will change by 1 dB for each 1 dB of attenuation change.

8.1.4 Setup (for noise test set method). This method is for utilizing a noise test set for directly setting  $E_b/N_0$  as shown in [Figure 8-2](#). Once the bit rate and noise bandwidth are set in the noise test set, the signal is applied and the noise test set will measure carrier power, allowing direct control over  $E_b/N_0$  by varying the noise N.

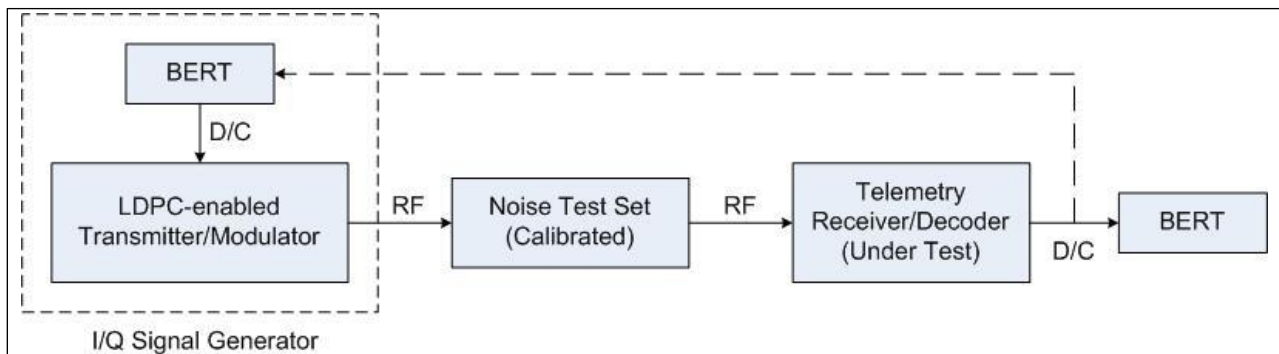



Figure 8-2. Setup for Noise Test Set BEP Test

<p><b>NOTE</b></p> 	<p>The bit rate set in the noise test set is the uncoded bit rate. The noise test set uses the following equation to set <math>E_b/N_0</math> directly:</p> $\frac{E_b}{N_0} (dB) = 10 \log \left( \frac{C}{N} \right) + 10 \log \left( \frac{IF BW}{Bit Rate} \right)$
--	---

8.1.5 Setup (for receiver analyzer method). This method utilizes a receiver analyzer for generating the LDPC-encoded waveform and directly setting  $E_b/N_0$  as shown in [Figure 8-3](#). Most receiver analyzers will require configuration of the test (in this case  $E_b/N_0$  vs. BEP) and of the signal source. After these steps, setting  $E_b/N_0$  directly will be possible and the signal from the receiver analyzer will have the exact amount of additive white Gaussian noise (AWGN) required for that setting of  $E_b/N_0$ .

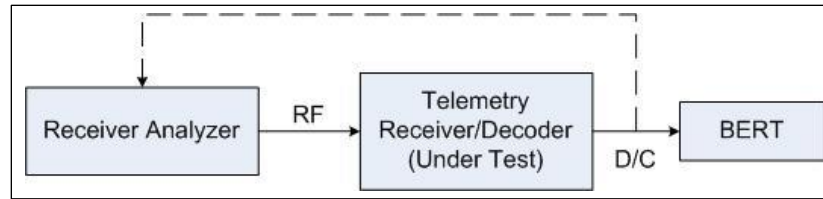

Figure 8-3. Setup for Receiver Analyzer BEP Test

8.1.6 Conditions. This test can be performed using any of the three setups that perform the following:

- A waveform signal source followed by an attenuator and a TM receiver/decoder that are then calibrated in terms of  $E_b/N_0$ ;
- A waveform signal source plus a noise test set that generates the signal at the selected  $E_b/N_0$  directly;
- An integrated waveform signal source/calibrated additive noise source (receiver analyzer) that generates the signal at the desired  $E_b/N_0$  directly.

If a TM transmitter is not used as the signal source, the signal should be non-linearly amplified to better reflect detection performance in a typical TM link.

#### 8.1.7 Procedure

1. Set the BERT or source pattern to generate the desired bit rate with a pseudo-noise sequence length of at least  $2^{11}-1$  (2047) bits and preferably at least  $2^{20}-1$  bits long (the longer sequence is a better simulation of the characteristics of an encrypted signal). Set the signal source to generate the required modulation scheme and combination of information block size/code rate for the LDPC code. (If available, amplify the signal with a non-linear amplifier). As a quick check, use a spectrum analyzer to verify the signal spectrum looks like the expected modulated waveform with calculated bandwidth expansion per IRIG-106 Appendix 2D<sup>7</sup> given the code rate  $r$  and information block size  $k$ .
2. Set the receiver/decoder to match the combination of center frequency and modulation scheme/information block size/code rate chosen for the modulator. Set the initial  $E_b/N_0$  to approximately 10 dB (as explained in Subsection 8.1.3 step 3) and verify that the BERT synchronizes in the non-inverted state. If the BERT does not synchronize, invert the output data polarity of the receiver/decoder. If the BERT now synchronizes, there is a polarity inversion somewhere.
3. Detection efficiency depends upon the selected code rate and information block size. IRIG-106 Appendix 2D has reference detection curves that illustrate the steepness of the curves. In general, regardless of the code rate/block size, starting with an initial  $E_b/N_0$  of approximately 5 dB or greater will yield error-free data. Decrease  $E_b/N_0$  in 1-dB steps until errors are encountered. At this point, increase  $E_b/N_0$  by 0.1-dB steps until error-free data is once again observed and record this  $E_b/N_0$  as the starting value on the data sheet. Measure the BER in

<sup>7</sup> Range Commanders Council. "Low-Density Parity-Check Codes for Telemetry Systems." Appendix 2D in *Telemetry Standards*. RCC 106-22. May 2022. May be superseded by update. Retrieved 13 May 2022. Available at <https://www.trmc.osd.mil/wiki/x/EoPOBg>.

0.1-dB intervals (reduce the  $E_b/N_0$  by 0.1 dB for each step) and record the  $E_b/N_0$  and BEP on Data Sheet 8-1. Allow BER to stabilize prior to annotating on the data sheet.

Code blocks typically decode as error-free or with a large number of bit errors. This, coupled with detection failures of the attached synchronization marker (ASM), will cause the resulting BER to become very bursty, resulting in stair-step detection curves. In order to attain smoother detection curves, the analysis period has to be greatly extended compared to uncoded systems. Because LDPC decoding is an iterative process, performance improves when the decoder has time to perform more decoding iterations. With typical decoding schemes the number of iterations scales inversely with bit rate, necessitating testing at several uncoded bit rates.

4. Repeat for other modulation schemes, information block lengths, code rates, and baseband data rates as desired.

8.1.8 Data Reduction. Compare the measured BEP versus  $E_b/N_0$  with the specification. Plot the data with a linear-logarithmic X-Y scale. If required, interpolate between points to estimate the BEP at a given  $E_b/N_0$  or to find the  $E_b/N_0$  that is required for a given BEP.

<b>Data Sheet 8-1. Receiver/Decoder Detection Performance</b>																					
<b>Test 8.1</b>	<b>Bit Error Probability versus <math>E_b/N_0</math></b>																				
Manufacturer:	Model:																				
Serial No.:																					
Test Personnel:	Date:																				
Center frequency: _____ MHz      Modulation: _____																					
Uncoded Bit Rate: _____ Mbps      Coded Bit Rate: _____ Mbps																					
Coding Rate: 1/2 2/3 4/5    Code Block: 1024 4096																					
<table border="1" style="margin: auto; border-collapse: collapse;"> <thead> <tr> <th style="width: 40%; padding: 5px;"><math>E_b/N_0</math></th> <th style="padding: 5px;">Bit Error Probability</th> </tr> </thead> <tbody> <tr><td style="height: 20px;"> </td><td> </td></tr> <tr><td style="height: 20px;"> </td><td> </td></tr> <tr><td style="height: 20px;"> </td><td> </td></tr> <tr><td style="height: 20px;"> </td><td> </td></tr> <tr><td style="height: 20px;"> </td><td> </td></tr> <tr><td style="height: 20px;"> </td><td> </td></tr> <tr><td style="height: 20px;"> </td><td> </td></tr> <tr><td style="height: 20px;"> </td><td> </td></tr> <tr><td style="height: 20px;"> </td><td> </td></tr> </tbody> </table>		$E_b/N_0$	Bit Error Probability																		
$E_b/N_0$	Bit Error Probability																				

## 8.2. TEST: Receiver/Decoder Threshold

8.2.1 Purpose. This test determines the  $E_b/N_0$  for receiver/decoder threshold. Threshold is defined as the value of  $E_b/N_0$  required for a resulting BEP of  $1 \times 10^{-2}$ . Reaching the threshold value can occur two ways, when the signal gradually degrades eventually reaching threshold or when acquiring the signal after a signal loss event.

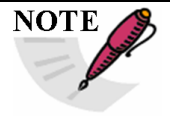
 <b>NOTE</b>	Given the extremely high values of BEP that an LDPC receiver/decoder must maintain synchronization coupled with the threshold BEP of $1 \times 10^{-2}$ , a BERT that can maintain bit synchronization to at least a BEP of $1 \times 10^{-2}$ is required.
---	---

8.2.2 Test Equipment. Modulator with LDPC encoding (e.g. TM transmitter, I/Q signal source, receiver analyzer), BERT, noise source (attenuator/power meter, noise test set, receiver analyzer), spectrum analyzer.

8.2.3 Setup. Connect test equipment as shown in [Figure 8-1](#), [Figure 8-2](#), or [Figure 8-3](#) depending on the test equipment available.

8.2.4 Conditions. This test can be performed using any of the three setups that perform the following:

- A waveform signal source followed by an attenuator and a TM receiver/decoder calibrated in terms of  $E_b/N_0$ ;
- A waveform signal source plus a noise test set that generates the selected  $E_b/N_0$  directly;
- An integrated waveform signal source/calibrated additive noise source (receiver analyzer) that generates the selected  $E_b/N_0$  directly.

### 8.2.5 Procedure

1. Set the BERT or source pattern to generate the desired bit rate with a pseudo-noise sequence length of at least  $2^{11}-1$  (2047) bits and preferably at least  $2^{20}-1$  bits long (the longer sequence is a better simulation of the characteristics of an encrypted signal). Set the signal source to generate the required modulation scheme and combination of information block size/code rate for the LDPC code. (If available, amplify the signal with a non-linear amplifier). As a quick check, use a spectrum analyzer to verify the signal spectrum looks like the expected modulated waveform of choice with calculated bandwidth expansion per IRIG-106 Appendix 2D given the code rate  $r$  and information block size  $k$ .
2. Set the receiver/decoder to match the combination of center frequency and modulation scheme/information block size/code rate chosen for the modulator. Set the initial  $E_b/N_0$  to 5 dB and verify that the BERT synchronizes to the bit pattern and is error-free. Decrease the  $E_b/N_0$  in 1-dB steps until a BEP of  $1 \times 10^{-3}$  is observed, then decrease in 0.1-dB steps until a BEP of  $1 \times 10^{-2}$  is reached; this is the  $E_b/N_0$  at threshold. Record this value of  $E_b/N_0$  in Data Sheet 8-2, Threshold.
3. Set the  $E_b/N_0$  to the threshold value determined in step 2. Mute the RF output on the signal source and verify the BER tester is out of synchronization. Unmute the signal source, maintaining the threshold  $E_b/N_0$ . If the signal is reacquired rapidly [ $< 1 \times 10^6 \cdot (\text{bit period})$ ], then record this  $E_b/N_0$  on Data Sheet 8-2, Re-acquisition threshold. If the signal is not rapidly reacquired, repeat the process with the  $E_b/N_0$  increased in 0.1-dB steps until rapid resynchronization occurs and record that value in Data Sheet 8-2, Re-acquisition threshold.

4. Repeat for other modulation schemes, information block lengths, code rates, and baseband data rates as desired.

8.2.6 Data Reduction. Compare the measured  $E_b/N_0$  threshold values with the specification.



<b>Data Sheet 8-2. Receiver/Decoder Threshold</b>									
<b>Test 8.2</b>	<b>Threshold <math>E_b/N_0</math></b>								
Manufacturer:	Model:								
Serial No.:									
Test Personnel:	Date:								
Center Frequency: _____ MHz      Modulation: _____ Uncoded Bit Rate: _____ Mbps      Coded Bit Rate: _____ Coding Rate: 1/2 2/3 4/5    Code Block: 1024 4096									
<table border="1" style="margin: auto; border-collapse: collapse;"> <thead> <tr> <th style="width: 80%;"></th> <th style="width: 20%;"><math>E_b/N_0</math></th> </tr> </thead> <tbody> <tr> <td style="padding: 5px;">Threshold</td> <td></td> </tr> <tr> <td style="padding: 5px;">Re-acquisition threshold</td> <td></td> </tr> <tr> <td style="padding: 5px;"> </td> <td></td> </tr> </tbody> </table>			$E_b/N_0$	Threshold		Re-acquisition threshold			
	$E_b/N_0$								
Threshold									
Re-acquisition threshold									

### 8.3. TEST: Receiver/Decoder Initial Acquisition Time and Flat Fade Recovery Time

8.3.1 Purpose. This test measures the time it takes for the receiver/decoder to synchronize after a long interval of no discernable input. In this case, due to the long outage the carrier is swept to simulate a Doppler shift in frequency. The purpose of the flat-fade recovery time test is to measure the time it takes for the receiver/decoder to synchronize after a fairly short interval of no discernable input. In this case the carrier is not swept due to the short time of the outage. In each case,  $E_b/N_0$  is set to a level where the signal is virtually noise-free or set to a level causing a BEP of no higher than  $1 \times 10^{-6}$ .

Both tests reveal the total amount of time it takes for the demodulator to synchronize, locate and lock on to the ASM and iteratively decode the LDPC code block (plus other associated delays), and output the resulting data.

8.3.2 Test Equipment. Modulator with LDPC encoding with the ability to sweep the carrier frequency (e.g. I/Q signal source, receiver analyzer), BERT, noise source (attenuator/power meter, noise test set, receiver analyzer), noise source for no-signal case, digital oscilloscope, RF switch, switch controller, spectrum analyzer.

8.3.3 Setup. Connect test equipment as shown in [Figure 8-4](#).

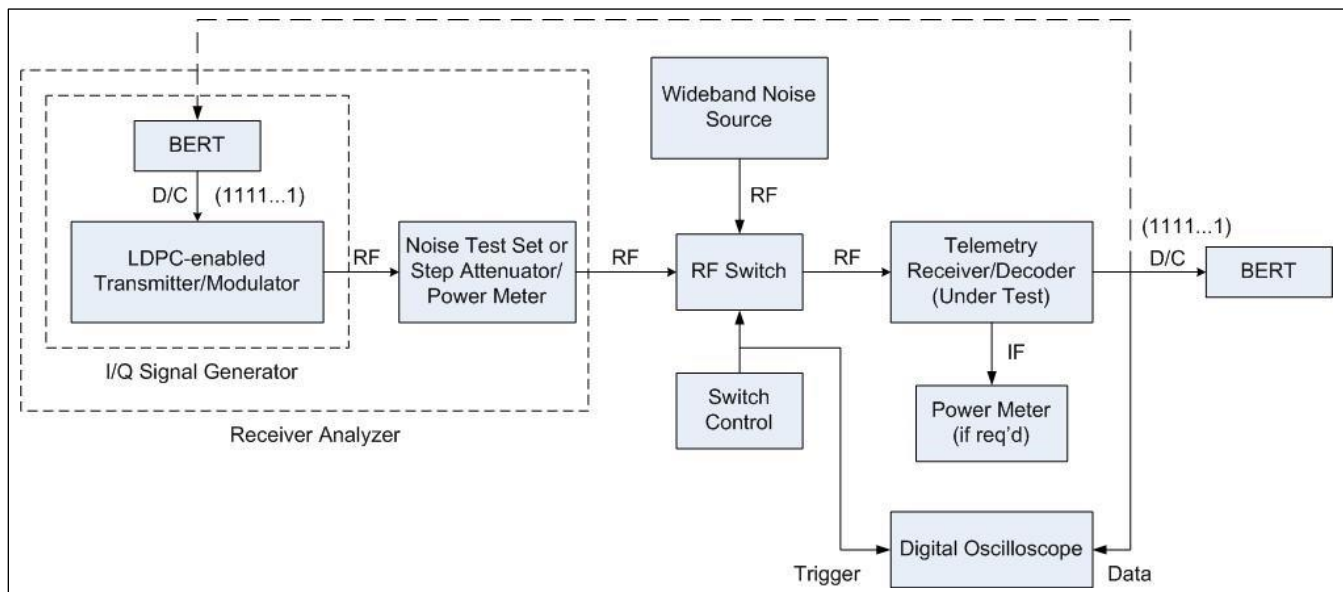

Figure 8-4. Test Setup for Receiver/Decoder Acquisition Time and Flat Fade Recovery Tests

8.3.4 Conditions. This test can be performed using one of the following: a signal source followed by an attenuator and a TM receiver that are then calibrated in terms of  $E_b/N_0$ ; a signal source plus a noise test set that generates the selected  $E_b/N_0$ ; or a receiver analyzer. The power level of the noise source connected to the RF switch should be set to approximately the same level as the TM signal in the bandwidth of interest to minimize the effect of the receiver AGC. The most commonly available choice for noise source is a receiver in manual gain mode with no input; however, other options are available. If the BERT has the capability of measuring acquisition time, it may be used in place of the digital oscilloscope. In all conditions, the signal

source should have the capability to sweep the carrier frequency at least  $\pm 20$  kHz with a ramp-up/ramp-down (triangle waveform) profile with the ability to set the waveform period.

### 8.3.5 Procedure

1. There are two methods available to generate the baseband test signal. Method one uses an IRIG randomizer with all ones input pattern to achieve the baseband test signal. A randomized sequence of ones should produce ones at the output of the de-randomizer/receiver if the de-randomizer/receiver is implementing the IRIG de-randomizer correctly. Method two sets the BERT to generate the desired bit rate with a pseudo-noise sequence length of  $2^{15}-1$  bits. Ensure the output from this method is all ones after de-randomization; invert the data if required. (Note: The exact method for generating this sequence must be verified, as using feedback from register taps 14 and 15 ensures compatibility with the IRIG 15 stage de-randomizer). Set the signal source to generate the required center frequency, modulation scheme, and combination of information block size/ code rate for the LDPC code. (If available, amplify the signal with a non-linear amplifier). Verify the proper signal spectrum is generated using the spectrum analyzer. Ensure the RF switch is passing the signal to the receiver/decoder. Set the receiver/decoder to de-randomize the input signal. As ones were input to the randomizer the de-randomized output should be all ones if there are no bit errors. Any bit errors will show up as zeroes in the de-randomized output. Some receiver/decoders may output the zero or ones state when the demodulator is out of synchronization regardless of input data pattern. This should be checked and noted prior to performing the test and the proper inversion selected if required to ensure the zero state is the out-of-synchronization state.

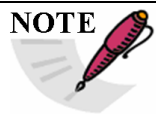

**NOTE** The IRIG-106 recommendation for randomization/de-randomization for an LDPC system is the Consultative Committee for Space Data Systems randomizer/de-randomizer. While either randomizer/de-randomizer can be used for this test, it is recommended to use the IRIG randomizer/de-randomizer due to legacy equipment support and its unique compatibility with a properly generated pseudo-noise sequence length of  $2^{15}-1$ .

2. Set the receiver/decoder to match the combination of center frequency, modulation scheme, and information block size/code rate chosen for the modulator. Set the initial  $E_b/N_0$  to something greater than 20 dB, which will ensure additive noise will not bias the test result. Using the RF switch control signal as the trigger, configure the digital oscilloscope to trigger on the transition from noise to the signal and measure intervals of about 500 ms (this value may need to be varied with bit rate to capture the actual acquisition times with sufficient accuracy). Set the signal source to sweep the carrier frequency  $\pm 20$  kHz, or to a range compatible with the carrier capture range of the receiver. A good starting point for the sweep period would be 4 kHz/s.
3. Initial Acquisition Test - Set the RF switch to pass the signal for about 2 seconds and the noise signal for about 8 seconds in a pattern that repeats every 10 seconds. The initial acquisition time is the time at which the output data is stable in the all ones state. Repeat the test enough times to get repeatable results and record the minimum, maximum, and average acquisition times on Data Sheet 8-3 (see note below). Repeat this step for an  $E_b/N_0$  that results in a BEP no higher than  $1 \times 10^{-6}$ . If required, repeat for various combinations of input frequency, sweep range/period, and information block size/code rate.

4. Flat-Fade Recovery Test – Disable carrier frequency sweeping and decrease the time in which the receiver/decoder sees the noise signal to 1500 ms and then to 500 ms. The flat-fade recovery time is the time at which the output data is stable in the all ones state. Repeat the test enough times to get repeatable results and record the minimum, maximum, and average acquisition times on Data Sheet 8-3 (see note below). Repeat this step for an  $E_b/N_0$  that results in a BEP no higher than  $1 \times 10^{-6}$ . If required, repeat for various combinations of input frequency and information block size/code rate.

8.3.6 Data Reduction. If specified, compare the measured acquisition and reacquisition times with the values in the specification.

 <b>NOTE</b>	There should be a range of acquisition values measured for both tests. This is primarily due to the frequency in which the ASM is present, the selected information block size/code rate, and where in the ASM/code block structure the RF signal is re-applied to the receiver/decoder.
---	--

Data Sheet 8-3. Receiver/Decoder Synchronization																																																																																
<b>Test 8.3</b>	<b>Acquisition Time and Flat Fade Recovery Time</b>																																																																															
Manufacturer:			Model:																																																																													
Serial No.:																																																																																
Test Personnel:			Date:																																																																													
Center frequency: _____ MHz																																																																																
Uncoded Bit rate: _____ Mbps      Coded Bit Rate: _____ Mbps																																																																																
Coding Rate: 1/2 2/3 4/5    Code Block: 1024 4096																																																																																
Carrier sweep range _____ kHz    Sweep Rate _____ Hz																																																																																
Switch on-time (signal) _____ seconds																																																																																
Switch off-time (noise): _____ seconds																																																																																
<table border="1" style="width: 100%; border-collapse: collapse; text-align: center;"> <thead> <tr> <th rowspan="2" style="width: 25%;">Frequency (MHz)</th> <th rowspan="2" style="width: 25%;">Bit Rate (Mbps)</th> <th rowspan="2" style="width: 25%;">E<sub>b</sub>/N<sub>0</sub> (dB)</th> <th colspan="3" style="width: 25%;">Acquisition Time (μs)</th> </tr> <tr> <th>Min</th> <th>Max</th> <th>Avg</th> </tr> </thead> <tbody> <tr><td> </td><td> </td><td> </td><td> </td><td> </td><td> </td></tr> <tr><td> </td><td> </td><td> </td><td> </td><td> </td><td> </td></tr> <tr><td> </td><td> </td><td> </td><td> </td><td> </td><td> </td></tr> <tr><td> </td><td> </td><td> </td><td> </td><td> </td><td> </td></tr> <tr><td> </td><td> </td><td> </td><td> </td><td> </td><td> </td></tr> <tr><td> </td><td> </td><td> </td><td> </td><td> </td><td> </td></tr> <tr><td> </td><td> </td><td> </td><td> </td><td> </td><td> </td></tr> <tr><td> </td><td> </td><td> </td><td> </td><td> </td><td> </td></tr> <tr><td> </td><td> </td><td> </td><td> </td><td> </td><td> </td></tr> <tr><td> </td><td> </td><td> </td><td> </td><td> </td><td> </td></tr> <tr><td> </td><td> </td><td> </td><td> </td><td> </td><td> </td></tr> </tbody> </table>						Frequency (MHz)	Bit Rate (Mbps)	E <sub>b</sub> /N <sub>0</sub> (dB)	Acquisition Time (μs)			Min	Max	Avg																																																																		
Frequency (MHz)	Bit Rate (Mbps)	E <sub>b</sub> /N <sub>0</sub> (dB)	Acquisition Time (μs)																																																																													
			Min	Max	Avg																																																																											

## 8.4. TEST: Receiver/Decoder Latency Time

8.4.1 **Purpose.** This test measures the latency added by the receiver/decoder to iteratively decode the LDPC code block (plus other associated delays) when acquiring/reacquiring a TM signal. This amount of time is precisely the time it takes the receiver/decoder to output invalid or highly errored data at the start of a fade or resync event. This test measures this amount of time.

8.4.2 **Test Equipment.** Modulator with LDPC encoding (e.g. I/Q signal source, receiver analyzer), BERT, noise source for no-signal case, digital oscilloscope, RF switch, switch controller, spectrum analyzer.

8.4.3 **Setup.** Connect test equipment as shown in [Figure 8-5](#).

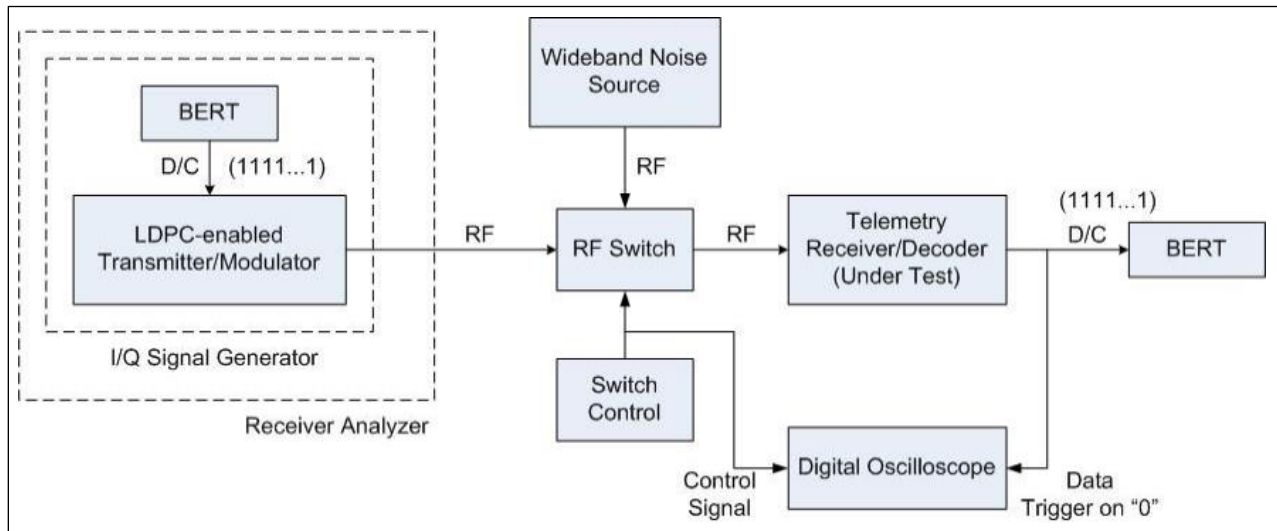



Figure 8-5. Test Setup for Receiver/Decoder Latency Time Test

8.4.4 **Conditions.** This test can be performed using a signal source/modulator with LDPC encoding (e.g. I/Q vector generator, TM transmitter, receiver analyzer). The power level of the noise source connected to the RF switch should be set to approximately the same level as the TM signal in the bandwidth of interest to minimize the effect of the receiver AGC. A receiver in MGC mode with no input would be one choice for the noise source. The digital oscilloscope should be configured to capture both the switching signal and the data output from the receiver/decoder.

### 8.4.5 Procedure

1. Perform step 1, Subsection [8.3.5](#).

<p><b>NOTE</b></p> 	<p>The IRIG-106 recommendation for randomization/de-randomization for an LDPC system is the Consultative Committee for Space Data Systems randomizer/de-randomizer. While either randomizer/de-randomizer can be used for this test, it is recommended to use the IRIG randomizer/de-randomizer due to legacy equipment support and its unique compatibility with a properly generated pseudo-noise sequence length of <math>2^{15}-1</math>.</p>
--	---

2. Set the receiver/decoder to match the combination of center frequency, modulation scheme, and information block size/code rate chosen for the modulator. Set the signal levels into and

out of the RF switch to be within the linear range of the receiver/decoder (a typical level would be  $-40$  dBm). Configure the digital oscilloscope to display both the RF switch control signal and the level of the data output from the receiver/decoder.

3. Trigger the oscilloscope on the data transition from a one to a zero. As a start, configure the RF control switch signal to output a square wave at a frequency of 1 Hz and adjust the period as needed.
4. Measure the time between when the RF signal to the receiver/decoder is removed to the time when a zero appears at the data output.
5. Repeat this test enough times to get repeatable results and record the minimum, maximum, and average latency times on Data Sheet 8-4.

8.4.6 Data Reduction. If specified, compare the stated latency time with the measured amount.

This test coupled with Test 8.3 gives a complete picture of the latencies and delays associated with LDPC capture and decoding after a signal loss event. Both tests in Test 8.3 reveal the total amount of time it takes for the demodulator to synchronize, locate, and lock on to the ASM; iteratively decode the LDPC code block (plus other associated delays); and output the resulting data. This test measured a portion of the total time, which is the latency added by the receiver/decoder to iteratively decode the LDPC code block (plus other associated delays) when acquiring/reacquiring a TM signal. By subtracting the value(s) measured in Test 8.3 with the value(s) measured in this test, you can determine the range of latency values associated with just demodulator synchronization and ASM detection and lock. This is depicted in Figure 8-6.

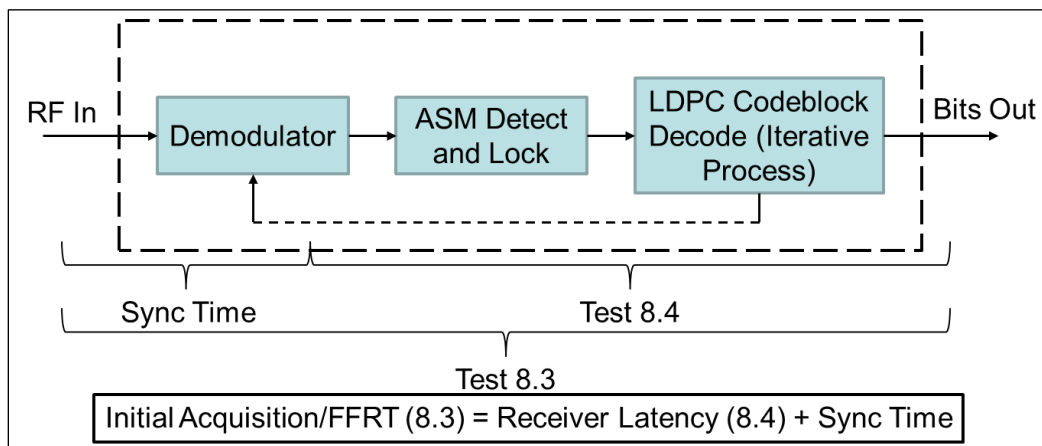

Figure 8-6. Receiver/Decoder Latency Tests

<b>Data Sheet 8-4.      Signal Acquisition Latency Time</b>																																																																
<b>Test 8.4</b>	<b>Receiver/Decoder Latency Time</b>																																																															
Manufacturer:	Model:																																																															
Serial No.:																																																																
Test Personnel:	Date:																																																															
Center frequency: _____ MHz																																																																
Uncoded Bit rate: _____ Mbps      Coded Bit Rate: _____ Mbps																																																																
Coding Rate: 1/2 2/3 4/5    Code Block: 1024 4096																																																																
Signal Level _____ dBm																																																																
Switch on-time (signal) _____ seconds																																																																
Switch off-time (noise): _____ seconds																																																																
<table border="1" style="width: 100%; border-collapse: collapse; text-align: center;"> <thead> <tr> <th rowspan="2" style="width: 25%;">Frequency (MHz)</th> <th rowspan="2" style="width: 25%;">Bit Rate (Mbps)</th> <th colspan="3" style="width: 50%;">Latency Time (μs)</th> </tr> <tr> <th style="width: 16.6%;">Min</th> <th style="width: 16.6%;">Max</th> <th style="width: 16.6%;">Avg</th> </tr> </thead> <tbody> <tr><td> </td><td> </td><td> </td><td> </td><td> </td></tr> <tr><td> </td><td> </td><td> </td><td> </td><td> </td></tr> <tr><td> </td><td> </td><td> </td><td> </td><td> </td></tr> <tr><td> </td><td> </td><td> </td><td> </td><td> </td></tr> <tr><td> </td><td> </td><td> </td><td> </td><td> </td></tr> <tr><td> </td><td> </td><td> </td><td> </td><td> </td></tr> <tr><td> </td><td> </td><td> </td><td> </td><td> </td></tr> <tr><td> </td><td> </td><td> </td><td> </td><td> </td></tr> <tr><td> </td><td> </td><td> </td><td> </td><td> </td></tr> <tr><td> </td><td> </td><td> </td><td> </td><td> </td></tr> <tr><td> </td><td> </td><td> </td><td> </td><td> </td></tr> </tbody> </table>		Frequency (MHz)	Bit Rate (Mbps)	Latency Time (μs)			Min	Max	Avg																																																							
Frequency (MHz)	Bit Rate (Mbps)			Latency Time (μs)																																																												
		Min	Max	Avg																																																												



## 8.5. TEST: Receiver/Decoder Adjacent Channel Interference Test

8.5.1 **Purpose.** This test measures the effect on BEP of the victim signal when the interfering signal(s) is in adjacent frequency channels. The results will be a function of modulation method, information block size/code rate for the LDPC code, receiver filter characteristics, bit rates, relative power levels, frequency spacing, and receiver/decoder characteristics in the presence of an interferer.

8.5.2 **Test Equipment.** Modulator with LDPC encoding (e.g. TM transmitter, I/Q signal source, receiver analyzer), BERT, TM signal sources (e.g. TM transmitter, I/Q signal source, receiver analyzer), attenuators, noise source, power dividers, spectrum analyzer (specialized test equipment such as a noise and interference test set and receiver analyzer can replace most of this test equipment if available).

8.5.3 **Test Method.** The method of this test is to set an  $E_b/N_0$  for BEP of  $1 \times 10^{-5}$  for the victim signal, increase the  $E_b/N_0$  by 1 dB, and then add the interferer(s) at a certain frequency offset(s) and at a certain carrier-to-interferer (C/I) ratio and observe any degradation of the victim signal. If there is no degradation of BEP, then the interferer(s) is either increased in amplitude or moved closer in frequency until a BEP of  $1 \times 10^{-5}$  is observed in the victim. This signifies 1 dB of degradation in  $E_b/N_0$ , which is the limit for acceptable adjacent-channel interference.

8.5.4 **Setup.** Connect test equipment as shown in [Figure 8-7](#).

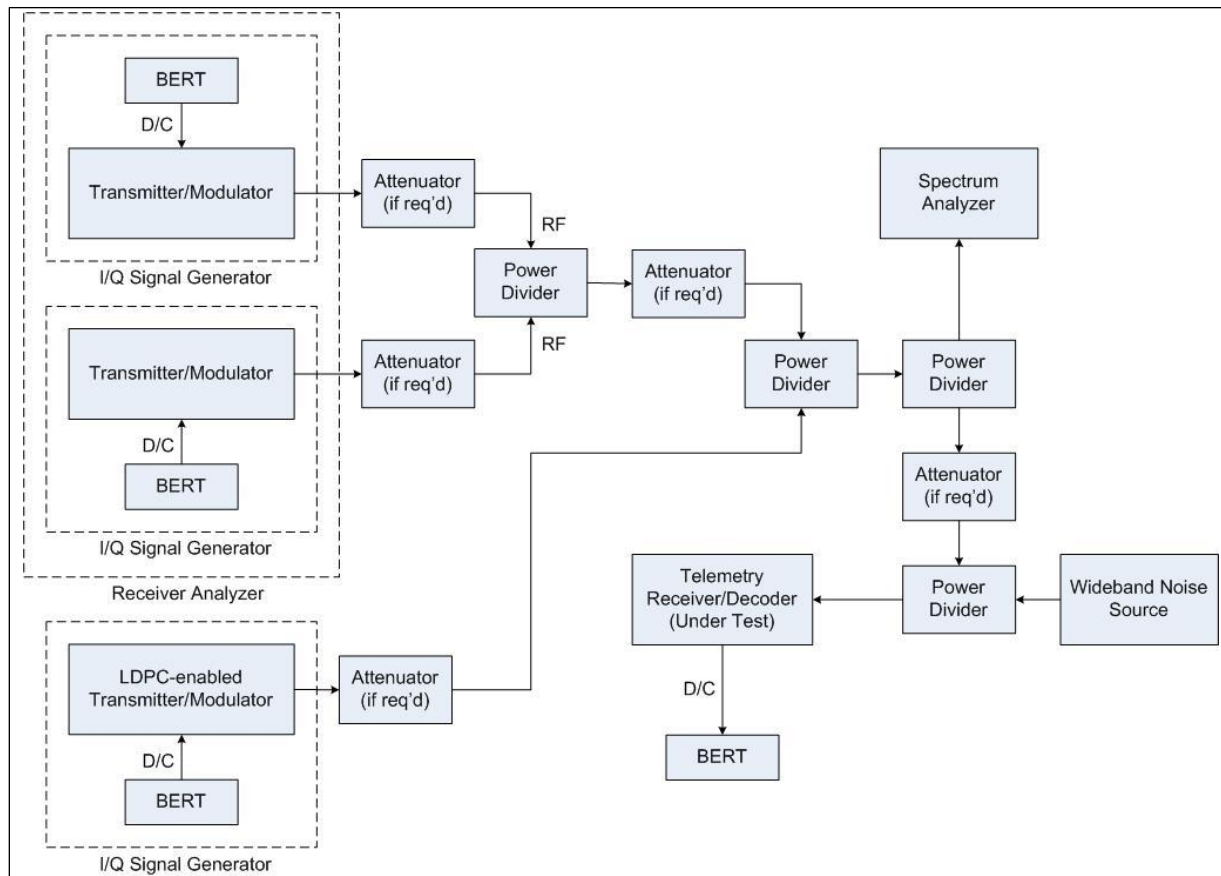

Figure 8-7. Test Setup for Adjacent Channel Interference Test

8.5.5 Conditions. This test can be performed using various modulation types as the interferers. The test can also be performed with only one interferer or with two interferers (one above and one below the victim signal frequency). This test can be performed with actual TM transmitters or with appropriate laboratory signal generators and/or a receiver analyzer. The laboratory generators should be passed through an amplifier of the same type as will be used in the actual transmitters (an amplifier operating in its non-linear range can be used if an amplifier of the proper type is not available.) If the purpose of the test is to evaluate performance during a test mission with a specific set of frequencies, bit rates, LDPC block size/coding rate, and modulation types, use these parameters for the test.

#### 8.5.6 Procedure

1. Set the BERT or data pattern of the signal source (this signal will be the center signal and called the victim or carrier, C) to generate the desired bit rate with a pseudo-random bit sequence length of at least  $2^{11}-1$  bits. The modulator output of the victim will typically need to be non-linearly amplified to simulate a typical TM transmitter. Similarly, configure the other TM signal source(s) with independent pseudo-noise sequences at the desired bit rate and modulation mode. Non-linearly amplify the outputs if possible. Set the center frequencies of these signals to the desired locations above and below the frequency of the victim signal. A good starting point for these signals can be calculated using the adjacent-channel interference recommendations in IRIG-106 Appendix 2A<sup>8</sup>.
2. Apply maximum attenuation to the two interferers or mute the RF outputs to remove them from the input to the receiver/decoder. Set the attenuators and noise source level (or adjust the noise and interference test set if available) to produce a BEP of  $1 \times 10^{-5}$  for the victim signal. This attenuator will need to be in 0.1-dB steps in order to attain the required BEP. Increase the level of the victim signal by 1 dB. Given the steepness of the detection curves for LDPC, increasing the victim signal level by 1 dB will result in error-free data regardless of block size/code rate combination.
3. Use the spectrum analyzer to set the relative powers of the interfering signal(s). A typical starting point is to have the interfering signal(s) 20 dB larger ( $C/I=-20$  dB) than the victim signal. Vary the attenuator that is common to the two interferers until the BEP is again  $1 \times 10^{-5}$ . This attenuator will need to be in 0.1-dB steps in order to attain the required BEP. Measure the relative power levels of the victim and interferers and record on Data Sheet 8-5.
4. Repeat steps 2 and 3 for various bit rates, modulation types, block size/code rate, and center frequencies of the interferer(s) as desired.

8.5.7 Data Reduction. Subtract the victim (C) power level from the interferer (I) power level and record on Data Sheet 8-5.

---

<sup>8</sup> Range Commanders Council. "Frequency Considerations for Telemetry." Appendix 2A in *Telemetry Standards*. RCC 106-22. May 2022. May be superseded by update. Retrieved 13 May 2022. Available at <https://www.trmc.osd.mil/wiki/x/EoPOBg>.

<b>Data Sheet 8-5. Receiver/Decoder Interference Susceptibility</b>	
<b>Test 8.5</b>	<b>Adjacent Channel Interference</b>
Manufacturer:	Model:
Serial No.:	
Test Personnel:	Date:
Receiver IF Bandwidth _____ MHz	
Victim:	
Frequency _____ MHz	Bit rate _____ Mbps
Power _____ dBm	Modulation type _____
Coding Rate: 1/2 2/3 4/5 Code Block: 1024 4096	
Interferer 1: Frequency _____ MHz	Bit rate _____ Mbps
Power _____ dBm	Modulation type _____
Spacing from Victim _____ MHz	
Interferer 2: Frequency _____ MHz	Bit rate _____ Mbps
Power _____ dBm	Modulation type _____
Spacing from Victim _____ MHz	
Power level difference between Victim & Interferer(s), C/I _____ dB	
Receiver IF Bandwidth _____ MHz	
Victim: Frequency _____ MHz	
Power _____ dBm	Bit rate _____ Mbps
Modulation type _____	
Coding Rate: 1/2 2/3 4/5 Code Block: 1024 4096	
Interferer 1: Frequency _____ MHz	Bit rate _____ Mbps
Power _____ dBm	Modulation type _____
Spacing from Victim _____ MHz	
Interferer 2: Frequency _____ MHz	Bit rate _____ Mbps
Power _____ dBm	Modulation type _____
Spacing from Victim _____ MHz	
Power level difference between Victim & Interferer(s), C/I _____ dB	
Receiver IF Bandwidth _____ MHz	
Victim:	
Frequency _____ MHz	Bit rate _____ Mbps
Power _____ dBm	Modulation type _____
Coding Rate: 1/2 2/3 4/5 Code Block: 1024 4096	
Interferer 1: Frequency _____ MHz	Bit Rate _____ Mbps
Power _____ dBm	Modulation Type _____
Spacing from Victim _____ MHz	
Interferer 2: Frequency _____ MHz	Bit rate _____ Mbps
Power _____ dBm	Modulation type _____
Spacing from Victim _____ MHz	
Power level difference between Victim and Interferer(s), C/I _____ dB	

## 8.6. TEST: Transmitter/Encoder 99% Occupied Bandwidth and -25-dBm Bandwidth

8.6.1 **Purpose.** This test measures the 99% occupied bandwidth (OBW) and the -25-dBm bandwidth of an LDPC-coded TM waveform. These bandwidths can be used to determine if the system complies with its spectral occupancy requirements. An example of these bandwidth measurements are shown pictorially in [Figure 8-8](#) for an SOQPSK-LDPC (4096\_4/5) waveform with an uncoded data rate of 5 Mbps.

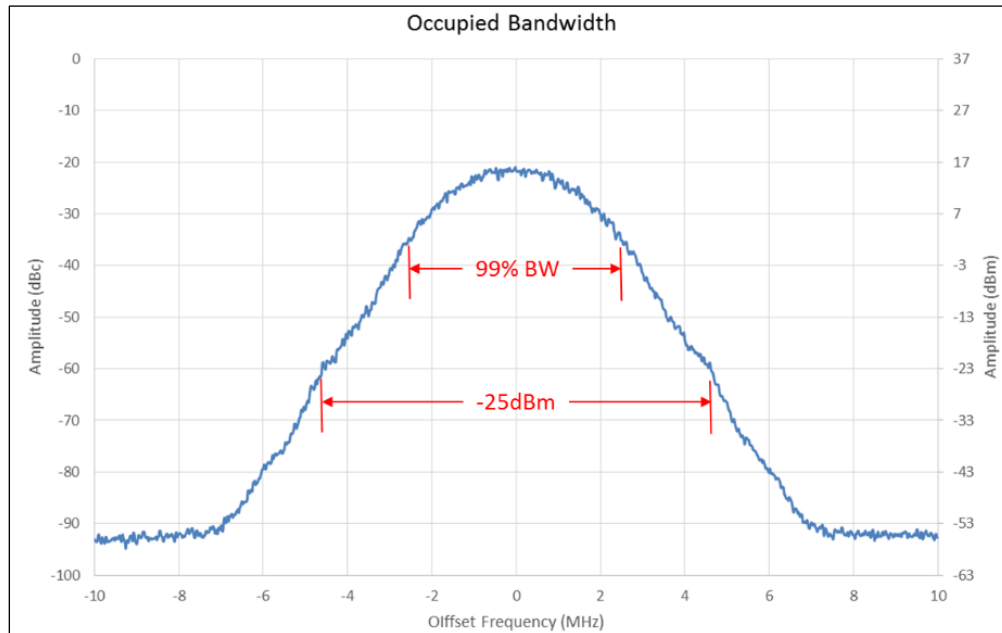

Figure 8-8. OBW Example 5 Mbps SOQPSK-LDPC (4096\_4/5)

8.6.2 **Test Equipment.** Spectrum analyzer with built-in OBW measurement suite, directional coupler, attenuators, power meter.

8.6.3 **Setup.** Connect the test equipment as shown in [Figure 8-9](#) for a laboratory test or [Figure 8-10](#) for an open-air test. The attenuator in [Figure 8-9](#) must be set properly in order to keep the input level to the spectrum analyzer below its maximum value.

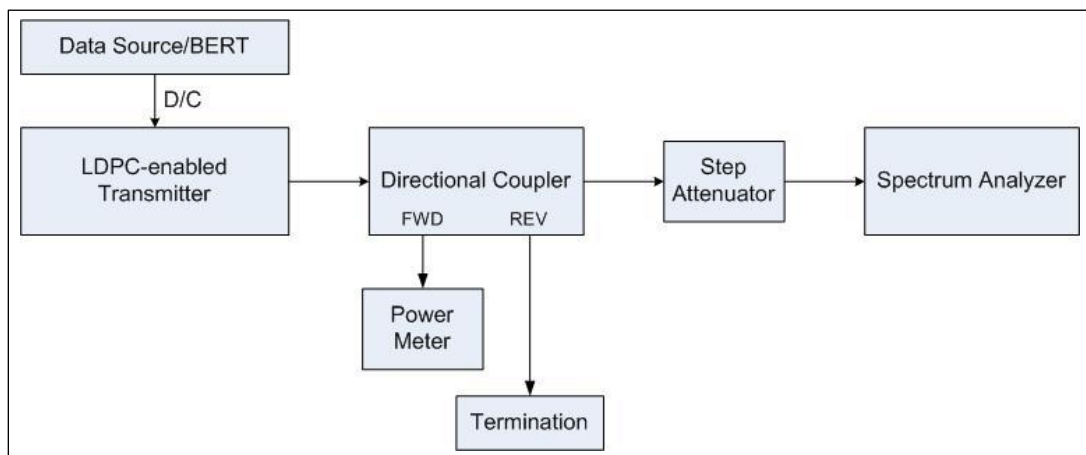

Figure 8-9. Test Setup for 99% Occupied Bandwidth and -25-dBm Bandwidth Test

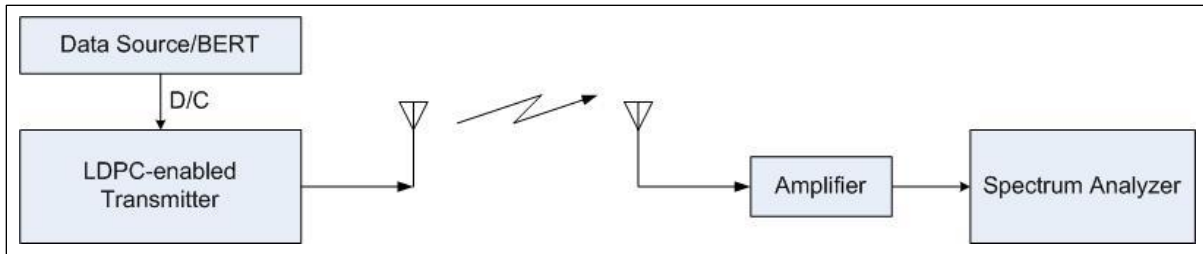

Figure 8-10. Over-the-Air Test Setup for 99% Occupied Bandwidth and  $-25$ -dBm Bandwidth

8.6.4 Conditions. This test can be performed with an LDPC-enabled TM transmitting system hard-wired in a laboratory environment or on the flight line, or with the system radiating from an antenna in an open-air environment. The most accurate bandwidth measurements will be obtained in a laboratory environment; however, reasonably accurate values can be obtained under operational conditions provided that severe multipath (or other propagation anomalies) is not present and that the received power levels are constant for the duration of the measurement. The bandwidth measurements are performed using a spectrum analyzer with the following settings: RBW=30 kHz, VBW=300 Hz, peak hold off and averaging off. These settings are consistent with the settings for spectral mask measurements.

#### 8.6.5 Procedure

1. Set the center frequency of the spectrum analyzer to match the transmitter carrier frequency. Adjust the span so all modulated components plus the noise floor of the spectrum analyzer are captured. A good rule of thumb is to have a minimum of 1 MHz of noise floor captured both above and below the modulated waveform. As a starting point, use four times the multiple of bit rate and bandwidth expansion factor for the code rate chosen to set the span.
2. If possible, set the TM transmitting system to transmit an unmodulated carrier. Take several sweeps with the spectrum analyzer to find the peak value, and set that value as the 0-dBc reference point (the top of the spectrum analyzer display). The peak value is the unmodulated carrier power at the spectrum analyzer input and will be used as the reference value for the bandwidth measurements.
3. If unmodulated carrier transmission is not possible, the total carrier power at the input to the spectrum analyzer can be found by setting the analyzer to its maximum RBW and VBW, selecting max (peak) hold, and allowing the analyzer to make several sweeps. The maximum value of the resulting trace will be a good approximation of the unmodulated carrier power for frequency and phase-modulated signals. Set the maximum value as the 0-dBc reference point (the top of the spectrum analyzer display). An example of this method is shown in [Figure 8-11](#).

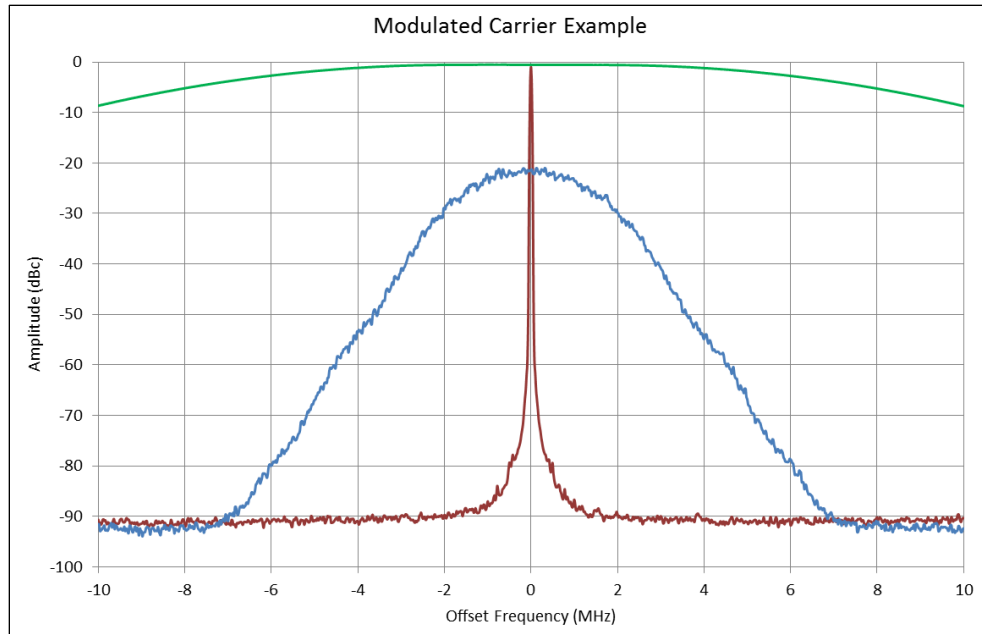

Figure 8-11. Spectrum Example for 0-dBc Determination

4. If possible, make a power measurement with a power meter and record that value in Data Sheet 8-6 after correcting for losses between the transmitting system and the power meter. If a direct power measurement is not possible, record the specified output power of the transmitting system for reference.
5. Using the spectrum analyzer settings, verify the carrier is modulated correctly and information block size/code rate for the LDPC code. Allow the analyzer to take several sweeps. For a cabled test, span should be set to the recommended width, also verifying that all spectral components decrease to at least  $-70$  dBc (this value may not be achievable for an open-air test). Perform the 99% OBW calculation with the spectrum analyzer. If the spectrum analyzer cannot directly measure this parameter, it is possible to capture and download the trace information and determine the frequencies at which 0.5% of the total power is above and below these frequencies. Record the upper and lower frequencies spanning the 99% OBW or the 99% OBW measured directly depending upon the method used in Data Sheet 8-6.
6. A power level of  $-25$  dBm is exactly equivalent to an attenuation of the transmitter power by:

$$P_t = 55 + 10\log(P) \quad (\text{Eq. 8-4})$$

where  $P$  is the transmitter power expressed in watts. For example, the  $-25$ -dBm level for a 10-W transmitter is  $-65$  dBc. Find the two frequencies where all spectral components are below the calculated level below the unmodulated carrier level. Record these upper and lower frequencies and the  $-25$ -dBm bandwidth using Data Sheet 8-6.

- 8.6.6 Data Reduction. Enter resulting data from the procedure in Data Sheet 8-6.

<b>Data Sheet 8-6. Occupied Bandwidth</b>	
<b>Test 8.6</b>	<b>99% Occupied Bandwidth and -25-dBm Bandwidth</b>
Manufacturer:	Model:
Serial No.:	
Test Personnel:	Date:
Center frequency: _____ MHz	Output Power: _____ W
Uncoded Bit rate: _____ Mbps	Coded Bit Rate: _____ Mbps
Coding Rate: 1/2 2/3 4/5 Code Block: 1024 4096	
99% Occupied Bandwidth	
Lower Frequency: _____ MHz	Upper Frequency: _____ MHz
99% OBW: _____ MHz	
-25-dBm Bandwidth	
Lower Frequency: _____ MHz	Upper Frequency: _____ MHz
-25-dBm Bandwidth: _____ MHz	

## 8.7. TEST: Transmitter/Encoder Spectral Mask Compliance

8.7.1 **Purpose.** This test verifies that the output of a transmitting system's RF port meets the spectral mask as defined in IRIG-106 Appendix 2A for each combination of information block size/code rate and modulation scheme.

8.7.2 **Test Equipment.** Spectrum analyzer, BERT, spectrum analyzer, attenuator(s).

8.7.3 **Setup.** Connect the test equipment as shown in [Figure 8-12](#). Note: If an external data source is used, ensure the baseband interfaces are matched between the BERT and transmitting system.

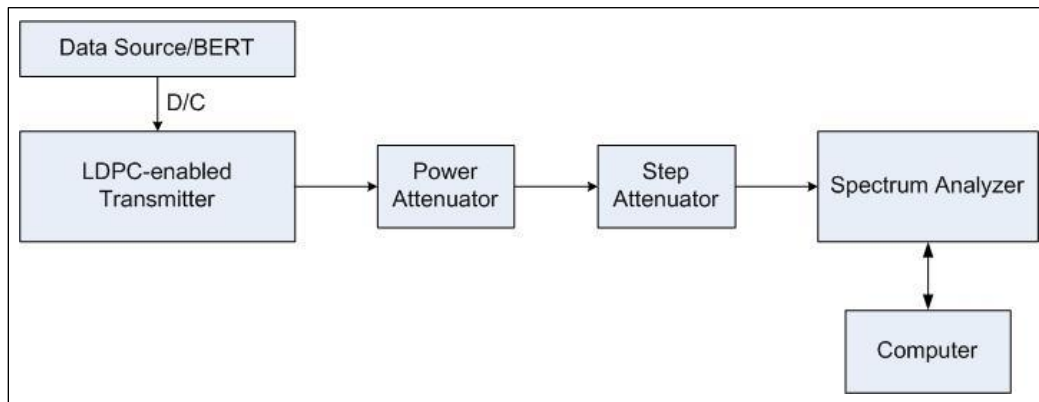

Figure 8-12. Test Setup for Spectral Mask Compliance

8.7.4 **Conditions.** This test should be done under laboratory conditions. The bandwidth measurements are performed using a spectrum analyzer.

8.7.5 **Procedure.** The spectrum analyzer should have the following settings.

- Center Frequency: Carrier frequency of the transmitting system.
  - Span: Appropriate for the combination of modulation mode and information block size/coding rate (suggest four times the multiple of bit rate and bandwidth expansion factor for the code rate chosen).
  - RBW=30 kHz, VBW=300 Hz
  - Peak Hold: Off
  - Averaging: Off
1. Per [Figure 8-12](#), connect the spectrum analyzer to the transmitting system's RF output through an attenuator(s) rated for the transmitting system's power with enough attenuation to protect the input to the spectrum analyzer. A value of 40 dB of attenuation is typical for a 10-W transmitter but one should determine the correct value based upon the output power of the transmitter and maximum input level to the spectrum analyzer. If using a BERT, connect it to the transmitting system at the desired clock rate/frequency and data pattern. Another method, if available, is to use the internal clock and data pattern generator of the transmitter to provide baseband data.
  2. There are several ways to place a TM transmitting system into carrier-only mode for determining the carrier power and subsequently the 0-dBc value.



- If using a BERT or the internal data and clock capability, use a data pattern to generate a carrier-only output. This will be modulation-mode dependent.
  - Alternatively, set the transmitter to carrier-only mode via an external serial interface that controls the transmitter directly. Once in carrier-only mode, measure the output power (carrier power) and record it on Data Sheet 8-7. Be sure to account for the attenuation between the transmitting system and spectrum analyzer. This will be the 0-dBc value.
  - Alternatively, and perhaps easier, once in carrier-only mode, adjust the attenuation so that the peak of the carrier is at the 0-dBm level of the spectrum analyzer. Once this is done, amplitude on the spectrum analyzer and in the spectrum capture file can be read directly as dBc.
3. Set the data source to generate a pseudo-random bit sequence length of at least  $2^{11}-1$  bits, preferably  $2^{20}-1$  or longer to better represent encrypted data. Set the desired modulation mode and information block size/coding rate for the LDPC code. Measure and capture the transmitted waveform with the spectrum analyzer and record the results on Data Sheet 8-7. If 0 dBc was set, the amplitude can be read in dBc directly. If not, convert the captured data to dBc by subtracting the measured carrier power from measured amplitude values.
  4. Compare the measured values with the spectral mask for the selected modulation scheme. The spectral masks are published in IRIG-106 Appendix 2A. The bit rate R required for the mask calculation must be adjusted based upon the block size/code rate for the LDPC code used during the test. The bandwidth expansion factor to be applied to R and subsequently the mask equation can be found in IRIG-106 Appendix 2D. Once the coded R value is determined, the placement of the waveform within the spectral mask can be verified by utilizing the J-Factor Equation specified in IRIG-106 Appendix 2A.

8.7.6 Data Reduction. Enter the results from the procedure in Data Sheet 8-7.

<b>Data Sheet 8-7. Spectral Mask</b>		
<b>Test 8.7</b>	<b>Transmitter Spectral Mask Compliance</b>	
Manufacturer:		Model:
Serial No.:		
Test Personnel:		Date:
Center frequency: _____ MHz	Output Power: _____ W	
Uncoded Bit rate: _____ Mbps	Coded Bit Rate: _____ Mbps	
Coding Rate: 1/2 2/3 4/5 Code Block: 1024 4096		
Frequency	Level (dBm)	Level (dBc)
Carrier		
Carrier – Bit Rate		
Carrier – 0.9*Bit Rate		
Carrier – 0.8*Bit Rate		
Carrier – 0.7*Bit Rate		
Carrier – 0.6*Bit Rate		
Carrier – 0.5*Bit Rate		
Carrier		
Carrier + 0.5*Bit Rate		
Carrier + 0.6*Bit Rate		
Carrier + 0.7*Bit Rate		
Carrier + 0.8*Bit Rate		
Carrier + 0.9*Bit Rate		
Carrier + Bit Rate		

## 8.8. TEST: LDPC-Enabled Transmitter/Encoder to Receiver/Decoder Interoperability

8.8.1 Purpose. This test verifies end-to-end operation of an LDPC-enabled TM system. Either the encoder or decoder can be verified if one has already been verified as correctly encoding (for the transmitting system) or decoding (for the receiver/decoder) per IRIG-106.

8.8.2 Test Equipment. Spectrum analyzer, BERT, attenuator(s), power divider.

8.8.3 Setup. Connect the encoder, decoder, and test equipment as shown in [Figure 8-13](#).

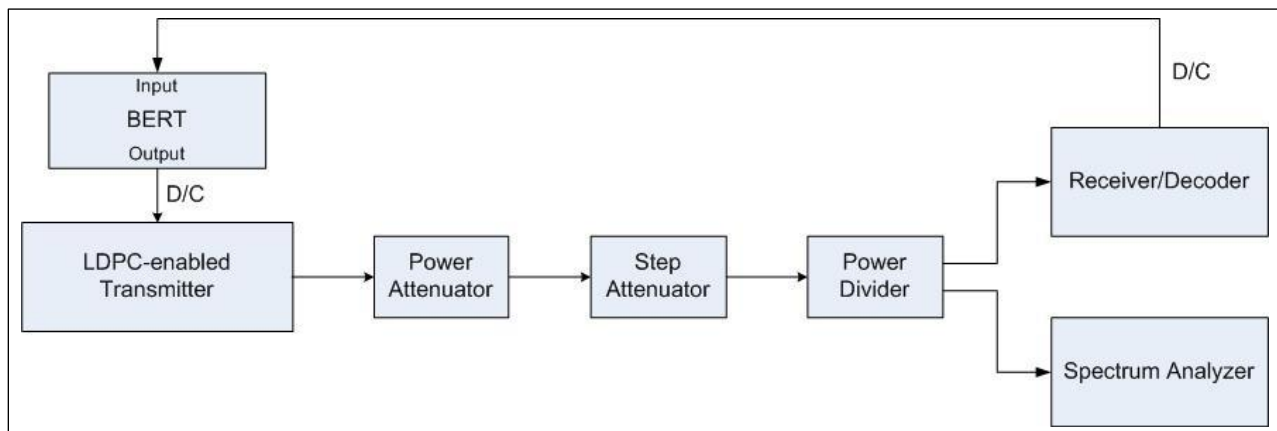

Figure 8-13. Test Setup for Interoperability

8.8.4 Conditions. This test is intended to be conducted in a laboratory environment.

### 8.8.5 Procedure

1. Set the data source to generate a pseudo-random bit sequence length of at least  $2^{11}-1$  bits, preferably  $2^{20}-1$  or longer to better represent encrypted data at the bit rate required for the test. With the RF muted, configure the transmitting system for the carrier frequency, proper modulation scheme, and block size/coding rate of the LDPC code. Enable the proper randomizer for LDPC per IRIG-106.
2. Set the attenuator levels so the receiver/decoder is operating well within its linear range. A typical value for a TM receiver would be an input level of  $-40$  dBm. Configure the receiver/decoder for the matching center frequency, proper modulation scheme, data rate, block size/code rate, and de-randomizer. Verify the BERT is set to detect the same pattern as is being generated. Unmute the RF output on the transmitting system and verify the receiver/decoder is receiving, demodulating, and decoding the signal. Verify synchronization of the BERT.
3. Once the BERT synchronizes, monitor the number of errors over a 15-minute interval. Record the number of errors the BERT counts over this interval on Data Sheet 8-8.

8.8.6 Data Reduction. Enter resulting data from the procedure in Data Sheet 8.8.

<b>Data Sheet 8-8. Interoperability</b>	
<b>Test 8.8</b>	<b>Transmitter to receiver interoperability</b>
Manufacturer:	Model:
Serial No.:	
Test Personnel:	Date:
Center frequency: _____ MHz      Output Power: _____ W	
Modulation Mode: PCMFM   SOQPSK   ARTM CPM   Data Pattern: _____	
Uncoded Bit rate: _____ Mbps      Coded Bit Rate: _____ Mbps	
Coding Rate: 1/2   2/3   4/5   Code Block: 1024   4096	
Bit Errors/15 Minute Interval: _____	

## CHAPTER 9

### Test Procedures for Space-Time Coding Capable Hardware

#### 9. General

Space-time coding (STC) has been implemented in telemetry hardware to overcome the two-antenna problem exhibited in many airborne telemetry systems. The following test procedures are recommended for testing telemetry systems used for STC encoding and decoding.

Nearly all the test procedures for SOQPSK-TG digital transmitting and receiving systems can also be performed with STC hardware. In general, these tests should be conducted with the two STC-encoded RF bit streams from the transmitter/encoder combined, as they would be seen through a transmission channel with zero frequency and delay offsets between the two STC signals.

The STC encoding adds pilot bits to the user data, resulting in a 26/25 bit rate expansion. The following procedures will identify two different bit rates. The “Input” bit rate is the pre-modulation bit rate without the 26/25 bit rate expansion. The OTA bit rate is the 26/25 expanded bit rate as a result of the added STC pilot bits.

[Table 9-1](#) lists the types of tests and their test and paragraph number.

<b>Table 9-1. Test Matrix for STC-Capable Telemetry Hardware</b>	
<b>Test Number</b>	<b>Test Description</b>
<a href="#">9.1</a>	Receiver/Decoder Bit Error Probability versus $E_b/N_0$
<a href="#">9.2</a>	Receiver/Decoder Reacquisition and Synchronization Loss Thresholds
<a href="#">9.3</a>	Receiver/Decoder Initial Acquisition and Flat Fade Recovery Times
<a href="#">9.4</a>	Receiver/Decoder Latency Time
<a href="#">9.5</a>	Receiver/Decoder Adjacent Channel Interference
<a href="#">9.6</a>	Transmitter/Encoder 99% Occupied Bandwidth and $-25$ dBm Bandwidth
<a href="#">9.7</a>	Transmitter/Encoder Spectral Mask
<a href="#">9.8</a>	Transmitter/Encoder to Receiver /Decoder Interoperability
<a href="#">9.9</a>	STC Signals with RF Combining

#### 9.1. TEST: Receiver/Decoder Bit Error Probability Versus $E_b/N_0$

9.1.1 **Purpose.** This test verifies the ability of a single-channel TM receiver/decoder to properly decode a pair of SOQPSK-STC modulated waveforms. The two waveforms may arrive at the receiver/decoder with differing amplitude, delay, and phase due to the physical environment, antenna locations, and differences in the over-the-air (OTA) propagation path.

This procedure tests specific amplitude and delay variances. Phase variances must also be considered. The STC demodulator performance may be affected by the relative phase of S0 and S1 signals. If these signals are combined at the RF level (as opposed to digitally), relative phase is dependent on carrier frequency, cable lengths, delays, etc. It is recommended that S0 have a small (roughly 1 Hz) frequency offset relative to S1 to make results as consistent as possible while facilitating use of varying equipment resources,. Doing this ensures all possible relative

phases are tested, and that results are averaged across those phases. This recommendation applies to all STC performance tests, not just BEP.

Test equipment resources vary at each location. This test illustrates three different test configurations. [Figure 9-1](#) uses a waveform signal source followed by an attenuator and a telemetry receiver/decoder that are then calibrated in terms of  $E_b/N_0$ . [Figure 9-2](#) uses a waveform signal source plus a noise test set that generates the signal at the selected  $E_b/N_0$  directly. [Figure 9-3](#) uses an integrated waveform signal source/calibrated additive noise source (receiver analyzer) that generates the signal at the desired  $E_b/N_0$  directly. Each of the three configurations has the ability to generate a calibrated  $E_b/N_0$  at the receiver/decoder input.

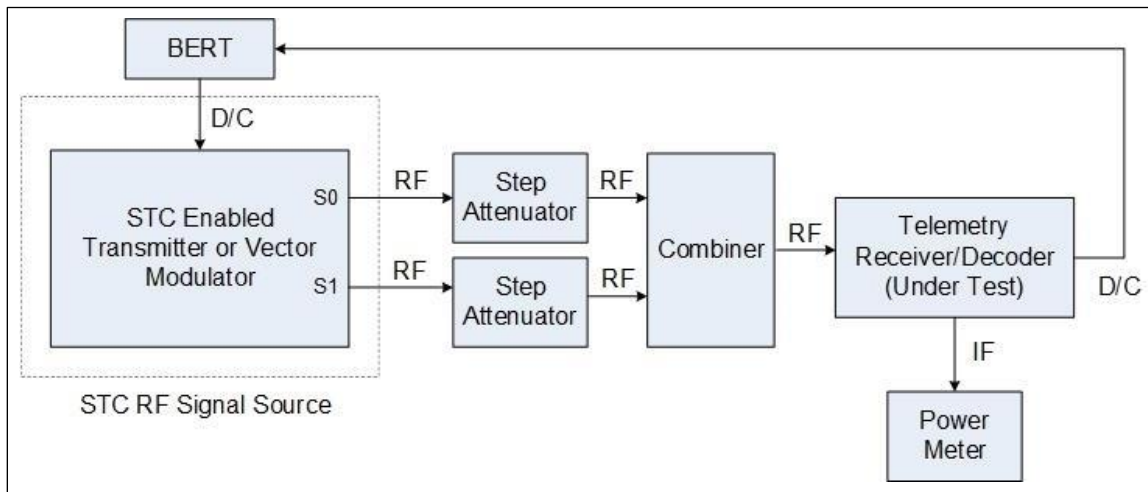

Figure 9-1. Setup for Step Attenuator/Power Meter Bit Error Probability Test

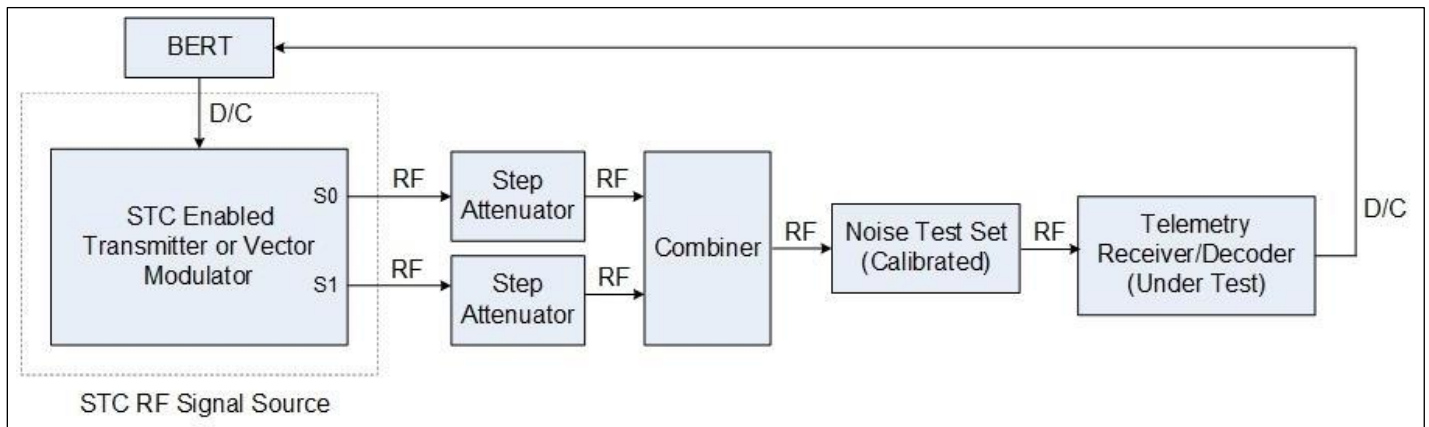

Figure 9-2. Setup for Noise Test Set Bit Error Probability Test

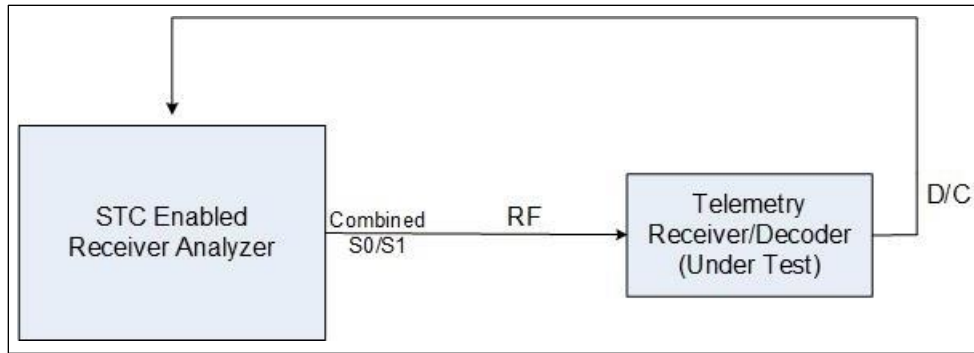

Figure 9-3. Setup for Receiver Analyzer/VSG Bit Error Probability Test

9.1.2 **Test Equipment.** An STC signal source, control of the differential amplitude, delay, and phase of the two STC signals, RF combiner, BERT.

9.1.3 **Setup (step attenuator/power meter method).** This method is for finding the attenuation that results in an  $E_b/N_0$  of 15 dB when the step attenuator/power meter method shown in [Figure 9-1](#) is used. Each measurement should be stable and repeatable to no more than 0.5 dB.

1. Connect the encoder/modulator as shown in [Figure 9-1](#).
2. Place the signal source in carrier-only mode. There are several ways of doing this depending upon the specific modulator being used. Turn off the source and set the attenuation to the maximum value. Use AGC freeze or manual gain to set the noise power at the receiver/decoder IF output in the linear region. Measure and note the IF power level in watts.
3. Turn on the source and decrease the attenuation until the power level at the IF output increases by 3 dB over the value recorded in step 2. Note this attenuation setting as it will be the baseline to work from. This value is the 0-dB IF carrier-to-noise ratio ( $C/N = 0$  dB) thus the  $E_b/N_0$  is given by:

$$\frac{E_b}{N_0} (dB) = 10 \log \left( \frac{IF BW}{Bit Rate} \right)$$

4. Put the receiver/decoder in AGC mode and decrease the attenuation by approximately:

$$15dB - 10 \log \left( \frac{IF BW}{Bit Rate} \right)$$

5. Use AGC freeze or manual gain to set the noise power at the receiver/decoder IF output in the linear region. Measure and note the IF power level in watts. This will be the carrier plus noise or  $C+N$  value. Note: The bit rate used in the equations is the “Input” bit rate. Units of  $IF BW$  and  $Bit Rate$  should be the same.
6. Turn off the source and set the attenuation to the maximum value. Measure the noise power level ( $N$ ) in watts. Calculate the  $E_b/N_0$ :

$$\frac{E_b}{N_0} (dB) = 10 \log \left( \frac{(C + N) - N}{N} \right) + 10 \log \left( \frac{IF BW}{Bit Rate} \right)$$

The most accurate value to use for IF bandwidth is the equivalent noise power bandwidth. If the  $-3$  dB bandwidth (either measured or specified) is the only value readily available, it will

give nearly the same value for  $E_b/N_0$ . If the measured value is not within 0.1 dB of 15 dB, change the attenuation by the appropriate amount to get within 0.1 dB of 15 dB and repeat the  $(C+N)$  and  $(N)$  measurements and calculations. The  $E_b/N_0$  is now calibrated and will change by 1 dB for each 1 dB of attenuation change.

9.1.4 Setup (noise test set method). Connect the encoder/modulator as shown in [Figure 9-2](#). This method is for utilizing a noise test set for directly defining  $E_b/N_0$  as shown in [Figure 9-2](#). Once the bit rate and noise bandwidth are entered in the noise test set, the signal is applied and the noise test set will measure carrier power allowing direct control over  $E_b/N_0$  by varying the noise  $N$ . Note: The bit rate entered in the noise test set is the “Input” bit rate. The noise test set uses the following equation to define  $E_b/N_0$  directly:

$$\frac{E_b}{N_0} (dB) = 10 \log \left( \frac{C}{N} \right) + 10 \log \left( \frac{IF BW}{Bit Rate} \right)$$

9.1.5 Setup (receiver analyzer/VSG method). Connect the encoder/modulator as shown in [Figure 9-3](#). This method utilizes a receiver analyzer or vector signal generator with internal AWGN capability for generating the STC S0 and S1 signals and directly setting  $E_b/N_0$  as shown in [Figure 9-3](#). Most receiver analyzers will require configuration of the test (in this case  $E_b/N_0$  vs. BEP) and of the signal source. After these steps, setting  $E_b/N_0$  directly will be possible and the signal from the receiver analyzer will have the exact amount of AWGN required for that setting of  $E_b/N_0$ .

9.1.6 Conditions. This test can be performed using any of the three setups as described in the last paragraph of Subsection [9.1.1](#). Differential delay, amplitude, and phase between S0 and S1 are controlled manually.

9.1.7 Procedure

### **S0/S1 Equal Amplitude**

1. Set the BERT to generate a pseudo noise pattern of at least  $2^{11}-1$  (PRN11), preferably longer to better simulate encrypted data, at the bit rate required for the test. With the RF muted, configure the transmitter/simulator system for the carrier frequency and SOQPSK-STC.
2. Set the signal level to the receiver/decoder to ensure it is operating well within its linear range. A typical value for a telemetry receiver/decoder would be an input level of  $-40$  dBm.
3. Configure the receiver/decoder for the matching center frequency, SOQPSK-STC, and data rate. Verify the BERT is set to detect the same pattern as it is generating. Unmute the RF output on the transmitting system and verify the receiver/decoder is receiving, demodulating, and decoding the signal. Verify the BERT detector synchronizes on the proper data pattern. If available on the receiver/decoder, monitor the front panel displays and verify there are no differential delay or amplitude differences in the received signal.
4. Set the initial  $E_b/N_0$  to approximately 15 dB and measure the bit errors in an interval of  $10^7$  or  $10^8$  bits. If the BER is larger than 1 per  $10^7$  bits, increase the  $E_b/N_0$  until the BER is less than that limit and record the  $E_b/N_0$  as the starting value on the data sheet.
5. Measure the BEP in 1-dB intervals (reduce the  $E_b/N_0$  by 1 dB for each step until the BEP  $\geq 10^{-2}$ ) and record the BEP on Data Sheet 9-1(A).



### **S0/S1 Individually**

6. Repeat [9.1.3](#) through [9.1.6](#) with S0 on and S1 off. Turning off S1 will require recalibrating the  $E_b/N_0$ . Enter data into Data Sheet 9.1(B).
7. Repeat [9.1.3](#) through [9.1.6](#) with S0 off and S1 on. Turning off S0 will require recalibrating the  $E_b/N_0$ . Enter data into Data Sheet 9.1(B).

### **S0/S1 Unequal Amplitude**

8. Repeat [9.1.3](#) through [9.1.6](#) using unequal input levels. Reduce the S1 signal level by 3, 10, and 20 dB from the S0 signal. Each new differential amplitude setting will require recalibrating the  $E_b/N_0$  by repeating [9.1.3](#) through [9.1.6](#). Record results on Data Sheet 9-1(C).

### **S0/S1 Unequal Delay**

NOTE: If a capable signal simulator is not available, a means to vary the delay of one RF signal path to the other is needed.

9. Set S0 and S1 to equal amplitude. Repeat [9.1.3](#) through [9.1.6](#). Repeat [9.1.6](#) with S1 signal delayed by  $\frac{1}{8}$ ,  $\frac{1}{4}$ ,  $\frac{3}{8}$ ,  $\frac{1}{2}$ ,  $\frac{5}{8}$ ,  $\frac{7}{8}$ ,  $\frac{3}{4}$ , and 1 bit intervals from S0. Record results on Data Sheet 9-1(D).
10. Repeat S0/S1 Equal Amplitude, S0/S1 Individually, S0/S1 Unequal Amplitude, and S0/S1 Unequal Delay tests for other bit rates as desired.

<b>Data Sheet 9-1(A). Bit Error Probability versus <math>E_b/N_0</math></b>																											
<b>Test 9.1(A)</b>	<b>With Equal S0/S1 Signal Levels</b>																										
<b>Manufacturer:</b> _____	<b>Model:</b> _____																										
<b>Serial No:</b> _____																											
<b>Test personnel:</b> _____	<b>Date:</b> _____																										
<b>Center Frequency</b> _____ (MHz)	<b>Bit Rate</b> _____ (Mbps)																										
<b>IF Filter BW</b> _____ (MHz)																											
<table border="1" style="margin: auto; border-collapse: collapse;"> <thead> <tr> <th style="padding: 5px;"><math>E_b/N_0</math></th> <th style="padding: 5px;">Bit Error Probability</th> </tr> </thead> <tbody> <tr><td style="text-align: center;">15</td><td></td></tr> <tr><td style="text-align: center;">14</td><td></td></tr> <tr><td style="text-align: center;">13</td><td></td></tr> <tr><td style="text-align: center;">12</td><td></td></tr> <tr><td style="text-align: center;">11</td><td></td></tr> <tr><td style="text-align: center;">10</td><td></td></tr> <tr><td style="text-align: center;">9</td><td></td></tr> <tr><td style="text-align: center;">8</td><td></td></tr> <tr><td style="text-align: center;">7</td><td></td></tr> <tr><td style="text-align: center;">6</td><td></td></tr> <tr><td style="text-align: center;">5</td><td></td></tr> <tr><td style="text-align: center;">4</td><td></td></tr> </tbody> </table>		$E_b/N_0$	Bit Error Probability	15		14		13		12		11		10		9		8		7		6		5		4	
$E_b/N_0$	Bit Error Probability																										
15																											
14																											
13																											
12																											
11																											
10																											
9																											
8																											
7																											
6																											
5																											
4																											

<b>Data Sheet 9-1(B). Bit Error Probability versus <math>E_b/N_0</math></b>																																															
<b>Test 9.1(B)</b>	<b>With S0 or S1 Only</b>																																														
<b>Manufacturer:</b> _____	<b>Model:</b> _____																																														
<b>Serial No:</b> _____																																															
<b>Test personnel:</b> _____		<b>Date:</b> _____																																													
<b>Center Frequency</b> _____ (MHz)	<b>Bit Rate</b> _____ (Mbps)																																														
<b>IF Filter BW</b> _____ (MHz)																																															
<table border="1" style="margin: auto; border-collapse: collapse;"> <thead> <tr> <th style="width: 15%; padding: 5px;"><math>E_b/N_0</math></th> <th colspan="2" style="padding: 5px;"><b>Bit Error Probability 1 Carrier Only</b></th> </tr> <tr> <td></td> <th style="width: 35%; padding: 5px;">S0 ON/S1 Off</th> <th style="width: 35%; padding: 5px;">S0 Off/S1 On</th> </tr> </thead> <tbody> <tr><td style="text-align: center;">15</td><td></td><td></td></tr> <tr><td style="text-align: center;">14</td><td></td><td></td></tr> <tr><td style="text-align: center;">13</td><td></td><td></td></tr> <tr><td style="text-align: center;">12</td><td></td><td></td></tr> <tr><td style="text-align: center;">11</td><td></td><td></td></tr> <tr><td style="text-align: center;">10</td><td></td><td></td></tr> <tr><td style="text-align: center;">9</td><td></td><td></td></tr> <tr><td style="text-align: center;">8</td><td></td><td></td></tr> <tr><td style="text-align: center;">7</td><td></td><td></td></tr> <tr><td style="text-align: center;">6</td><td></td><td></td></tr> <tr><td style="text-align: center;">5</td><td></td><td></td></tr> <tr><td style="text-align: center;">4</td><td></td><td></td></tr> <tr><td></td><td></td><td></td></tr> </tbody> </table>			$E_b/N_0$	<b>Bit Error Probability 1 Carrier Only</b>			S0 ON/S1 Off	S0 Off/S1 On	15			14			13			12			11			10			9			8			7			6			5			4					
$E_b/N_0$	<b>Bit Error Probability 1 Carrier Only</b>																																														
	S0 ON/S1 Off	S0 Off/S1 On																																													
15																																															
14																																															
13																																															
12																																															
11																																															
10																																															
9																																															
8																																															
7																																															
6																																															
5																																															
4																																															

<b>Data Sheet 9-1(C). Bit Error Probability versus <math>E_b/N_0</math></b>						
<b>Test 9.1(C)</b>	<b>STC Unequal Amplitude</b>					
	<b>S0/S1 Attenuation Levels (dB)</b>					
$E_b/N_0$	S0 -3dB S1 0dB	S0 -6dB S1 0dB	S0 -10dB S1 0dB	S0 0dB S1 -3dB	S0 0dB S1 -6dB	S0 0dB S1 -10dB
15						
14						
13						
12						
11						
10						
09						
08						
07						
06						
05						
04						

Data Sheet 9-1(D). Bit Error Probability versus $E_b/N_0$																
Test 9-1(D)		STC Unequal Delay														
		Delay in Bits														
	S0 1/8 S1 0	S0 1/4 S1 0	S0 3/8 S1 0	S0 1/2 S1 0	S0 5/8 S1 0	S0 3/4 S1 0	S0 7/8 S1 0	S0 1 S1 0	S0 0 S1 1/8	S0 0 S1 1/4	S0 0 S1 3/8	S0 0 S1 1/2	S0 0 S1 5/8	S0 0 S1 3/4	S0 0 S1 7/8	S0 0 S1 1
$E_b/N_0$		BER														
15																
14																
13																
12																
11																
10																
09																
08																
07																
06																
05																
04																

## 9.2. TEST: Receiver/Decoder Reacquisition and Synchronization Loss Thresholds

9.2.1 Purpose. This test measures the minimum  $E_b/N_0$  that results in consistent acquisition (defined as typically back in synchronization in a few seconds) and the  $E_b/N_0$  at which synchronization loss occurs. Depending on the receiver/decoder this could be a BER as high as  $5 \times 10^{-1}$ .

Note: Large values of BEP can be expected at the point of loss of synchronization. It is important that the BERT chosen can maintain bit synchronization to larger values of BEP, such as  $10^{-1}$ .

9.2.2 Test Equipment. BER test set, modulator with STC encoding (e.g. telemetry transmitter, I/Q signal source, receiver analyzer), noise source (attenuator/power meter, noise test set, receiver analyzer), and spectrum analyzer.

9.2.3 Conditions: This test can be performed with a properly calibrated  $E_b/N_0$  using any one of the three configurations shown in [Figure 9-1](#), [Figure 9-2](#), or [Figure 9-3](#).

### 9.2.4 Procedure

1. Set the BER test set or source pattern to generate the desired bit rate with a pseudo noise sequence length of at least  $2^{11}-1$  (2047) bits and preferably at least  $2^{20}-1$  bits long (the longer sequence is a better simulation of the characteristics of an encrypted signal). Set the signal source to generate SOQPSK-STC modulation.
2. Set the receiver/decoder to match the combination of center frequency and bit rate of the transmitting source. Set the initial  $E_b/N_0$  to approximately 15 dB and verify that the BER test set synchronizes. Decrease the  $E_b/N_0$  in 1-dB steps until the BER test set starts to lose synchronization. Some receiver/decoders have an internal assessment of synchronization. If this is available compare these results with those obtained with the BER test set. Use the value that best represents the performance of the system. Record the lowest value of  $E_b/N_0$  with solid synchronization on Data Sheet 9-2.
3. Set the  $E_b/N_0$  to the lowest value at which solid synchronization was maintained. Turn off the signal source. Turn the signal back on at the  $E_b/N_0$  set above. If the signal is reacquired rapidly, then record this  $E_b/N_0$  on Data Sheet 9-2. If the signal is not rapidly reacquired, repeat the process with the  $E_b/N_0$  increased in 1-dB steps until rapid resynchronization occurs.
4. Repeat steps 2 and 3 for other baseband data rates as desired.

9.2.5 Data Reduction. Compare the measured  $E_b/N_0$  values with the specification.

Data Sheet 9-2. Receiver/Decoder Acquisition and Synchronization									
<b>Test 9.2</b>	<b>Receiver/Decoder Acquisition and Synchronization Loss Thresholds versus <math>E_b/N_0</math></b>								
<p><b>Manufacturer:</b> _____ <b>Model:</b> _____</p> <p><b>Serial No:</b> _____</p> <p><b>Test Personnel:</b> _____ <b>Date:</b> _____</p> <p><b>Center Frequency</b> _____ (MHz) <b>Bit Rate</b> _____ (Mbps)</p> <p><b>Over the Air Bit Rate:</b> _____ (Mbps)</p>									
<table border="1" style="margin: auto; border-collapse: collapse;"> <thead> <tr> <th style="width: 50%;"></th> <th style="width: 50%;"><math>E_b/N_0</math></th> </tr> </thead> <tbody> <tr> <td style="padding: 5px;">Synchronization loss threshold:</td> <td style="height: 20px;"></td> </tr> <tr> <td style="padding: 5px;">Re-acquisition threshold:</td> <td style="height: 20px;"></td> </tr> <tr> <td style="padding: 5px;"></td> <td style="height: 20px;"></td> </tr> </tbody> </table>			$E_b/N_0$	Synchronization loss threshold:		Re-acquisition threshold:			
	$E_b/N_0$								
Synchronization loss threshold:									
Re-acquisition threshold:									

### 9.3. TEST: Receiver/Decoder Acquisition and Flat Fade Recovery Times

9.3.1 **Purpose.** This test measures the time it takes for the receiver/decoder to synchronize after a long interval of no discernable input. In this case, due to the long outage the carrier is swept to simulate a Doppler shift in frequency. The purpose of the flat fade recovery time test is to measure the time it takes for the receiver/decoder to synchronize after a fairly short interval of no discernable input. In this case the carrier is not swept due to the short time of the outage. In each case,  $E_b/N_0$  is set to a level where the signal is virtually noise-free or set to a level causing a BEP of no worse than  $1 \times 10^{-6}$ .

Both tests reveal the total amount of time it takes for the demodulator to synchronize; locate and lock on to the pilot bits; make estimations on frequency offset, differential timing, and transmission channel; decode the Alamouti-encoded block; and output the resulting data.

9.3.2 **Test Equipment:** BER test set, modulator with STC encoding (e.g., telemetry transmitter, I/Q signal source, receiver analyzer), noise source, digital oscilloscope, RF switch, switch controller, spectrum analyzer.

9.3.3 **Setup.** Connect test equipment as shown on [Figure 9-4](#).

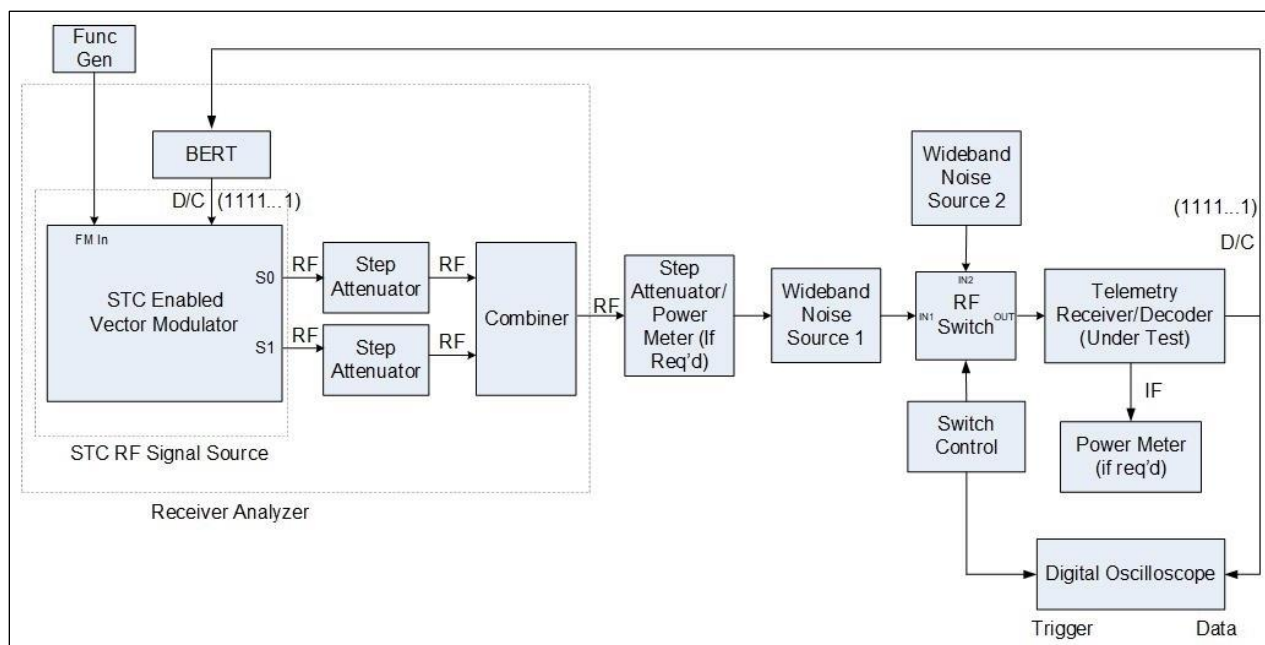

Figure 9-4. Test Setup for Receiver/Decoder Acquisition and Flat Fade Recovery

9.3.4 **Conditions.** This test can be performed using a signal source plus a noise test set that generates the selected  $E_b/N_0$ ; a signal source followed by an attenuator and a telemetry receiver/decoder that are then calibrated in terms of  $E_b/N_0$ ; or a receiver analyzer. The power level of the noise source should be set to approximate the level of the telemetry signal in the bandwidth of interest (a receiver/decoder in MGC mode with no input would be one choice for this noise source). If the BERT has the capability of measuring acquisition time, it may be used in place of the digital oscilloscope. In all conditions, when measuring the initial acquisition recovery times, the signal source should have the capability to sweep the carrier frequency at



least  $\pm 20$  kHz with a ramp-up/ramp-down (triangle waveform) profile with the ability to set the waveform period to approximately 16 seconds (2.5 KHz/s).

### 9.3.5 Procedure

1. There are several methods available to generate the baseband test signal. Method one uses an IRIG randomizer with all ones input pattern to achieve the baseband test signal, a randomized sequence of ones should produce ones at the output of the derandomized receiver/decoder if the derandomized receiver/decoder is implementing the IRIG de-randomizer correctly. Method two sets the BER test set to generate the desired bit rate with a pseudo-noise sequence length of  $2^{15}-1$  bits. Ensure the output from this method is all ones after de-randomization; invert the data if required. (Note: The exact method for generating this sequence must be verified, as using feedback from register taps 14 and 15 ensures compatibility with the IRIG 15-stage de-randomizer). Set the signal source to generate the required center frequency and SOQPSK-STC modulation. Verify the proper signal spectrum is generated using the spectrum analyzer. Ensure the RF switch is passing the signal to the receiver/decoder. Set the receiver/decoder to de-randomize the input signal. As ones were input to the randomizer the de-randomized output should be all ones if there are no bit errors. Any bit errors will show up as zeroes in the de-randomized output. Some receiver/decoders may output the zero or ones state when the demodulator is out of synchronization regardless of input data pattern. This should be checked and noted prior to performing the test and the proper inversion selected if required to ensure the zero state is the out-of-synchronization state.
2. Set the receiver/decoder to match the combination of center frequency and SOQPSK-STC modulation. Set the initial  $E_b/N_0$  to something greater than 20 dB, which will ensure additive noise will not bias the test result. Adjust the output level of wideband noise source 2 to the same level as the signal and wideband noise source 1. Using the RF switch control signal as the trigger, configure the digital oscilloscope to trigger on the transition from noise (wideband noise source 2) to signal plus noise (wideband noise source 1) and record intervals of about 500 ms (this value may need to be varied with bit rate to capture the actual acquisition times with sufficient accuracy). Set the signal source to sweep the carrier frequency  $\pm 20$  kHz, or to a range compatible with the carrier capture range of the receiver/decoder. A good starting point for the sweep period would be 2.5 kHz/s.
3. Initial Acquisition Test – Set the RF switch to pass the RF signal plus noise (wideband noise source 1) for about 2 seconds and the noise (wideband noise source 2) for 8 seconds. Continuously repeat this cycle. The initial acquisition time is the time from the switch trigger to the time at which the receiver/decoder output data is stable in the all ones state. Repeat the test enough times to get repeatable results and record the minimum, maximum, and average acquisition times on Data Sheet 9-3 (see note below).

 <b>NOTE</b>	There should be a range of acquisition values measured for both tests. This is primarily due to the frequency in which the pilot bits are present in the block and where in the block structure the RF signal is re-applied to the receiver/decoder.
---	--

4. Repeat steps 2 and 3 for an  $E_b/N_0$  that results in a BEP of  $1 \times 10^{-6}$ . If required, repeat for various combinations of input frequency, sweep range/period, or bit rate.

5. Flat Fade Recovery Test – Disable carrier frequency sweeping. Set the RF switch to pass the RF signal plus noise (wideband noise source 1) for 8.5 seconds and the noise (wideband noise source 2) for 1.5 seconds. The flat fade recovery time is the time at which the output data is stable in the all ones state. Repeat the test setting the RF switch to pass the RF signal plus noise (wideband noise source 1) for 9.5 seconds and the noise (wideband noise source 2) for 0.5 seconds. Repeat both tests enough times to get repeatable results and record the minimum, maximum, and average acquisition times on Data Sheet 9-3 (see note below).
  6. Repeat step 5 for an  $E_b/N_0$  that results in a BEP of  $1 \times 10^{-6}$ . If required, repeat for various combinations of input frequency and bit rate.
- 9.3.6 Data Reduction. Compare the measured acquisition and reacquisition times with the values in the specification.

Data Sheet 9-3. Receiver/Decoder Acquisition																																																																										
<b>Test 9.3</b>	<b>Receiver/Decoder Acquisition and Flat Fade Recovery Times</b>																																																																									
<b>Manufacturer:</b> _____			<b>Model:</b> _____																																																																							
<b>Serial No:</b> _____																																																																										
<b>Test Personnel:</b> _____			<b>Date:</b> _____																																																																							
Center Frequency	_____ (MHz)	Input Bit Rate	_____ (Mbps)																																																																							
Over the Air Bit Rate: _____																																																																										
Carrier sweep range		_____ kHz	Sweep Rate		_____ Hz																																																																					
Switch on time (signal)		_____ seconds																																																																								
Switch off-time (noise)		_____ seconds																																																																								
<table border="1" style="width: 100%; border-collapse: collapse; text-align: center;"> <thead> <tr> <th rowspan="2" style="width: 30%;">Frequency (MHz)</th> <th rowspan="2" style="width: 20%;">Bit Rate (Mb/s)</th> <th rowspan="2" style="width: 15%;">Eb/No (dB)</th> <th colspan="3" style="width: 35%;">Acquisition Time (μs)</th> </tr> <tr> <th style="width: 10%;"><u>Min</u></th> <th style="width: 10%;"><u>Max</u></th> <th style="width: 15%;"><u>Avg</u></th> </tr> </thead> <tbody> <tr><td> </td><td> </td><td> </td><td> </td><td> </td><td> </td></tr> <tr><td> </td><td> </td><td> </td><td> </td><td> </td><td> </td></tr> <tr><td> </td><td> </td><td> </td><td> </td><td> </td><td> </td></tr> <tr><td> </td><td> </td><td> </td><td> </td><td> </td><td> </td></tr> <tr><td> </td><td> </td><td> </td><td> </td><td> </td><td> </td></tr> <tr><td> </td><td> </td><td> </td><td> </td><td> </td><td> </td></tr> <tr><td> </td><td> </td><td> </td><td> </td><td> </td><td> </td></tr> <tr><td> </td><td> </td><td> </td><td> </td><td> </td><td> </td></tr> <tr><td> </td><td> </td><td> </td><td> </td><td> </td><td> </td></tr> <tr><td> </td><td> </td><td> </td><td> </td><td> </td><td> </td></tr> </tbody> </table>						Frequency (MHz)	Bit Rate (Mb/s)	Eb/No (dB)	Acquisition Time (μs)			<u>Min</u>	<u>Max</u>	<u>Avg</u>																																																												
Frequency (MHz)	Bit Rate (Mb/s)	Eb/No (dB)	Acquisition Time (μs)																																																																							
			<u>Min</u>	<u>Max</u>	<u>Avg</u>																																																																					

#### 9.4. TEST: Transmitter/Encoder and Receiver/Decoder Data Latency

9.4.1 Purpose. This test determines the delay in the transmitter, in the receiver, and the combination of transmitter and receiver for an SOQPSK-STC system.

9.4.2 Test Equipment. Digital pattern generator/BERT; mixed-domain oscilloscope (MDO).

9.4.3 Test Method. The use of STC requires the insertion of pilot bits used for estimation over the block of data being transmitted. The user data is combined with the STC pilot bits to form an STC frame. See [Figure 9-5](#). The STC frame data rate is increased by a factor of 26/25. This adds latency when compared to traditional serial streaming telemetry. See [Figure 9-6](#).

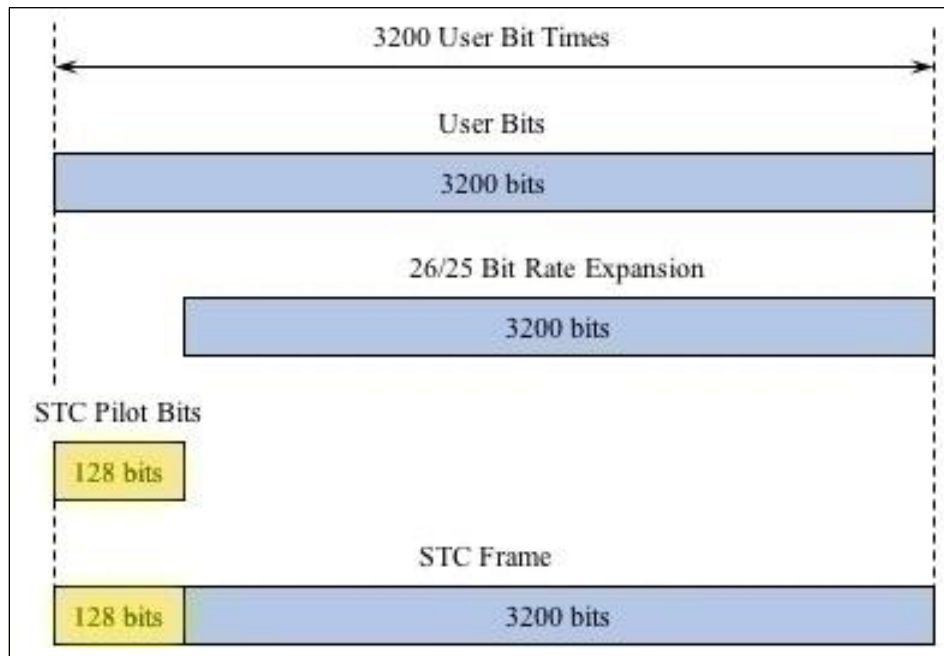

Figure 9-5. STC Frame

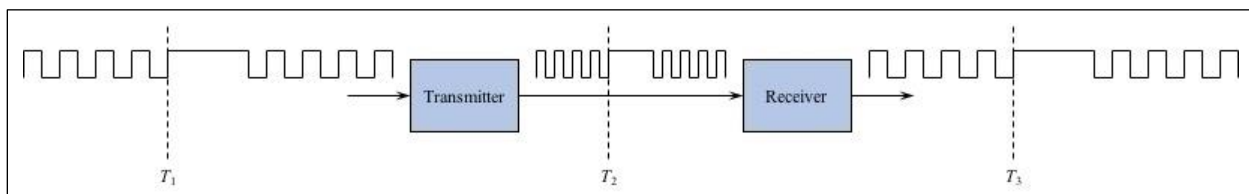

Figure 9-6. Measuring STC Latency

Total System Latency:  $L_{Total} = T_3 - T_1$

Transmitter/Encoder Latency:  $L_{Tx} = T_2 - T_1$

Receiver/Decoder Latency calculation:  $L_{Rx} = L_{Total} - L_{Tx}$

9.4.4 Description of [Figure 9-7](#) MDO Display. There are six traces on the display. The first three traces consist of: CH1 Oscilloscope (green), CH2 Oscilloscope (blue), and Freq ( $f$ ) vs Time (yellow). There is a zoom window noted by white brackets on the first three traces. The next three traces are the zoomed-in image of the three top traces inside the zoom brackets. When

measuring the transmitter/encoder latency the MDO is triggered by the BERT input on CH1. Although it is too small to see on the CH1 sweep, the trigger point is marked by the T at the top of the zoom window. The “b” marker is coincident with the trigger (T). The “a” marker is coincident with transmitter RF output, via the directional coupler, and is seen on the yellow  $f$  trace. The STC pilot bits are seen on the yellow  $f$  trace. The “a” & “b” marker measurements are referenced to the trigger position. The measurement below was done with a 5-Mbs data rate. As seen on [Figure 9-7](#)  $L_{Tx}$ , the time from the BERT trigger (T) to the Transmitter output (a), is 41.4  $\mu$ s.  $L_{Total}$ , the total delay to the RX output (CH2) is 193.4  $\mu$ s.

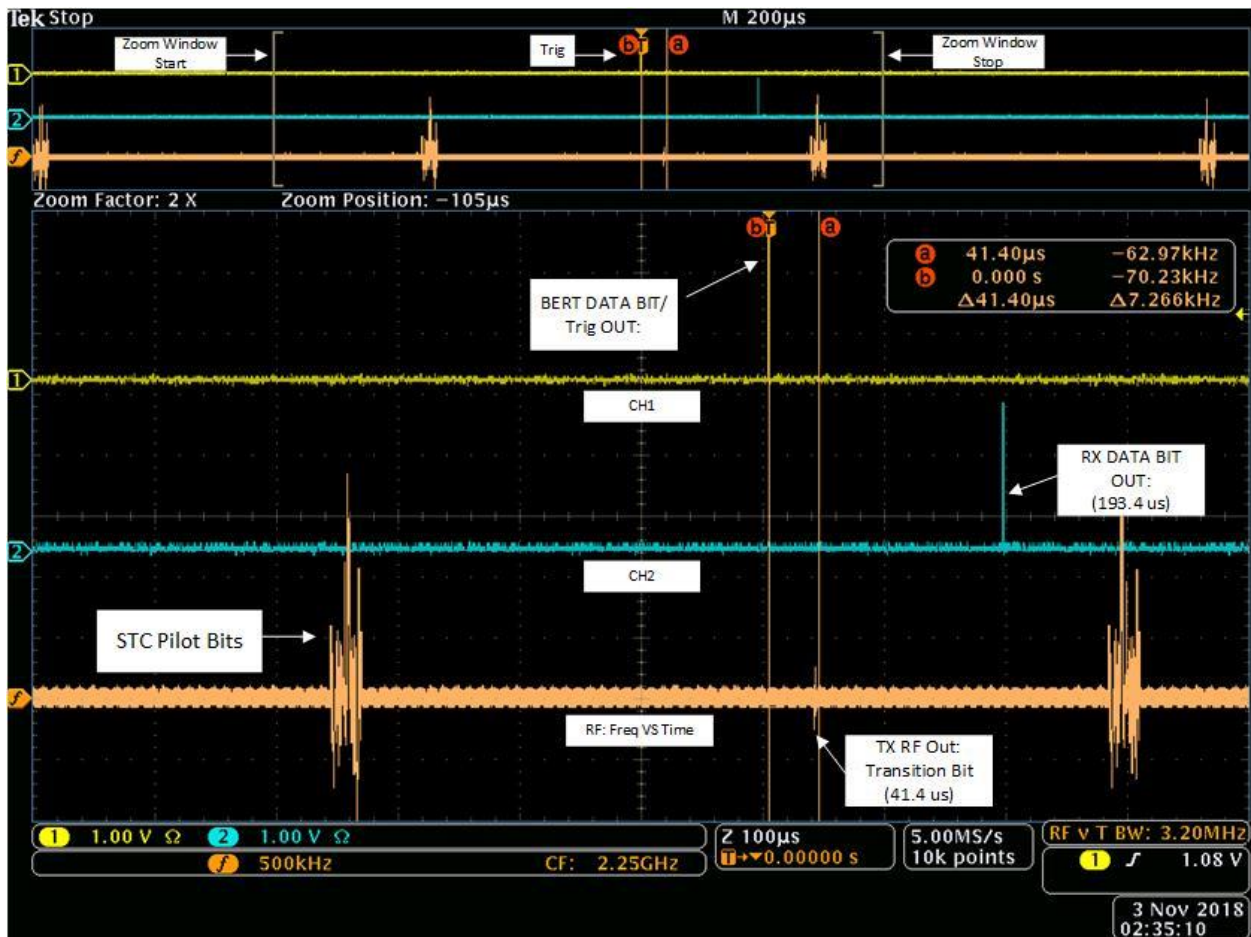

Figure 9-7. Mixed Domain Oscilloscope RF Latency (Transmitter) Measurement

MDO Settings	
RF VS Time Setting	FREQ: ON, AMP: Off, PHASE: Off
SPAN	3 MHz
START	2248.5 MHz
STOP	2251.5 MHz
RBW	20 KHz

9.4.5 **Setup.** Set up the equipment as in [Figure 9-8](#). Set the RF output of the transmitter/encoder using transmitter controls and/or attenuators for a reasonable RF level for the receiver/decoder and MDO (nominally  $-20$  dBm). Set the digital pattern generator/ BERT to provide all zeros with an on-command one-time one bit change (insert error). Set the transmitter/encoder and receiver/decoder to the desired bit rate.

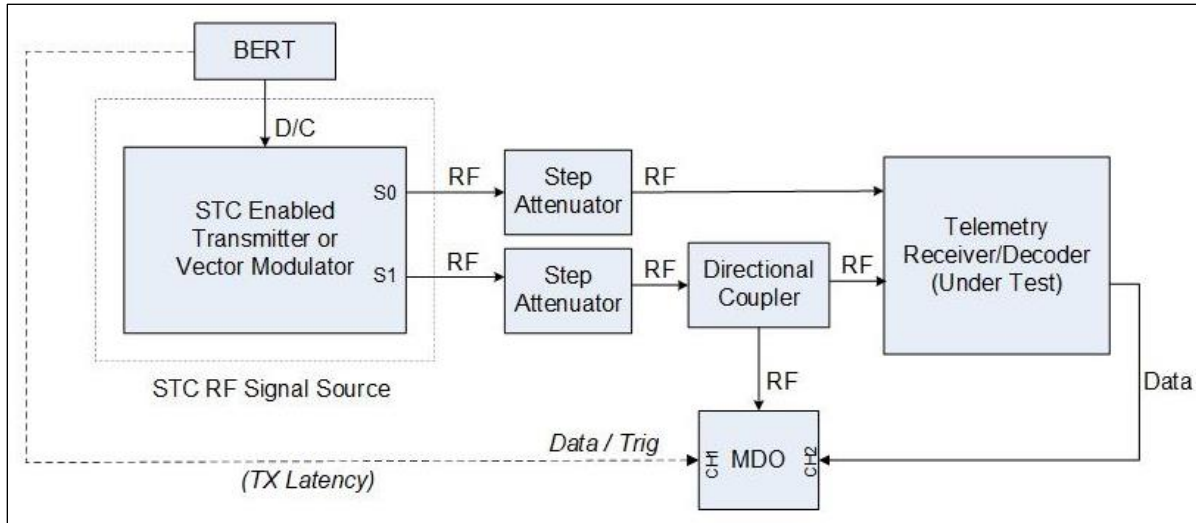

Figure 9-8. Data Latency

9.4.6 **Conditions.** The STC encoder formats blocks of data and appends pilot bits (refer to IRIG 106 Appendix 2-E<sup>9</sup>). Any data input bit can be assigned any position in the data block. The data latency measured should be an average.

9.4.7 **Procedure**

1. Determine the total system latency  $L_{Total}$  by connecting the MDO CH2 to the receiver data output. Connect the MDO CH1 to the BERT data output. Trigger the MDO from CH1. Insert a bit error on the BERT. Measure the time from the BERT output to the receiver/decoder data output on CH2. Record the  $L_{Total}$  result in Data Sheet 9-4.
2. Determine the transmitter latency ( $L_{Tx}$ ). Set the MDO RF input to the directional coupler port. Insert a bit error on the BERT. Measure the time from the BERT output (T) to the transmitter/encoder RF transition on the  $f$  trace. The RF transition signal will appear after the trigger on the MDO. The  $L_{Tx}$  will vary depending on where the transition bit is placed in the encoded block. Repeat this step several times and record the  $L_{Tx}$  average result in Data Sheet 9-4.
3. The receiver latency can be computed by subtracting  $L_{Rx} = L_{Total} - L_{Tx}$ .
4. Repeat steps 2 through 4 for other bit rates as desired.

<sup>9</sup> Range Commanders Council. "Space-Time Coding for Telemetry Systems." Appendix 2E in *Telemetry Standards*. RCC 106-22. May 2022. May be superseded by update. Retrieved 13 May 2022. Available at <https://www.trmc.osd.mil/wiki/x/EoPOBg>.

<b>Data Sheet 9-4. Transmitter/Encoder/Receiver/Decoder</b>			
<b>Test 9.4</b>	<b>Transmitter/Encoder/Receiver/Decoder Data Latency</b>		
<b>Manufacturer:</b> _____		<b>Model:</b> _____	
<b>TX Manufacturer:</b> _____		<b>Model:</b> _____	
<b>RX Manufacturer:</b> _____			
<b>Tx Serial No:</b> _____			
<b>Rx Serial No:</b> _____			
<b>Test Personnel:</b> _____		<b>Date</b> _____	
<b>Center Frequency</b>	<b>MHz</b>		
<b>BIT RATE (Mbps)</b>	<b><math>L_{Total}</math> (us) <math>L_{Total} = T_3 - T_1</math></b>	<b><math>L_{Tx}</math> (us) <math>L_{Tx} = T_2 - T_1</math></b>	<b><math>L_{Rx}</math> (us) <math>L_{Rx} = L_{Total} - L_{Tx}</math></b>
1			
2			
3			
4			
5			
6			
7			
8			
9			
10			
11			
12			
13			
14			
15			
16			
17			
18			
19			
20			
	<b>AVERAGE</b>	<b>AVERAGE</b>	<b>AVERAGE</b>

## 9.5. TEST: Demodulator Adjacent Channel Interference Test

9.5.1 **Purpose.** This test measures the effect on BEP of the victim signal when the interfering signal(s) is in adjacent frequency channels. The results will be a function of the STC coding, receiver/decoder filter characteristics, bit rates, relative power levels, frequency spacing, and receiver/decoder characteristics in the presence of an interferer.

9.5.2 **Test Equipment.** BER test sets, modulator with STC encoding (e.g., telemetry transmitter, I/Q signal source, receiver analyzer), telemetry signal source, attenuators, noise source, power dividers, spectrum analyzer. (Specialized test equipment such as a noise and interference test set and receiver analyzer can replace most of this test equipment if available.)

9.5.3 **Test Method.** The method of this test is to set an  $E_b/N_0$  for BEP of  $10^{-5}$  for the victim signal, increase the  $E_b/N_0$  by 1 dB, and then add the interferer(s) at a certain frequency offset(s) and a certain C/I ratio and observe any degradation of the victim signal. If there is no degradation of BEP, then the interferer(s) is either increased in amplitude or moved closer in frequency until a BEP of  $1 \times 10^{-5}$  is observed, signifying 1 dB of degradation in  $E_b/N_0$ , which is the limit for acceptable adjacent-channel interference.

9.5.4 **Setup.** Connect test equipment as shown in [Figure 9-9](#).

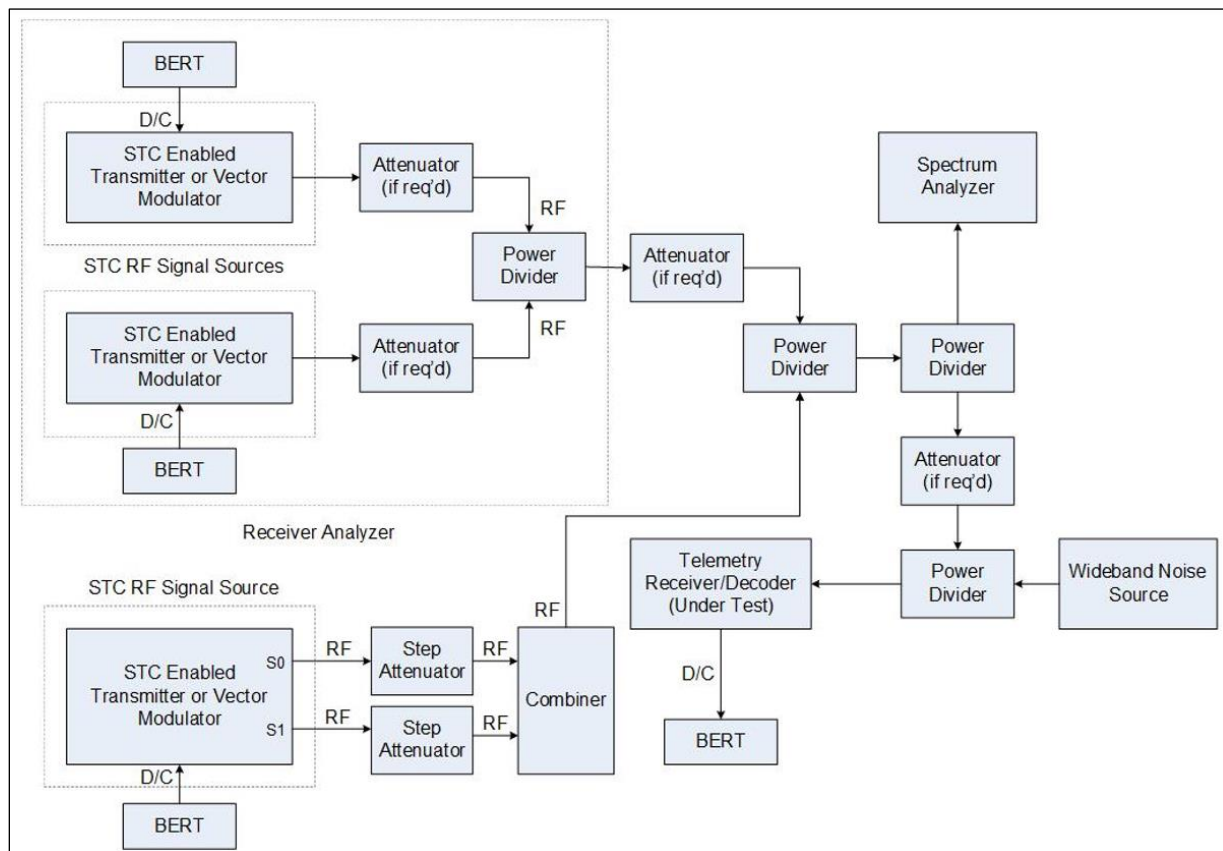

Figure 9-9. Setup for Adjacent Channel Interference Test

9.5.5 **Conditions.** This test can be performed using various modulation types as the interferers. The test can also be performed with only one interferer or with two interferers (one



above and one below the victim signal frequency). This test can be performed with actual telemetry transmitters or with appropriate laboratory signal generators and/or a receiver analyzer. The laboratory generators should be passed through an amplifier of the same type as will be used in the actual transmitters (an amplifier operating in its non-linear range can be used if an amplifier of the proper type is not available.) If the purpose of the test is to evaluate performance during a test mission with a specific set of frequencies, modulation scheme (for interferers), and bit rates, use these parameters for the test.

#### 9.5.6 Procedure

1. Set the BERT or data pattern of the signal source (this signal will be the center signal and called the victim or carrier, C) to generate the desired bit rate with a pseudo-random bit sequence length of at least  $2^{11}-1$  bits. The modulator output of the victim will typically need to be non-linearly amplified to simulate a typical telemetry SOQPSK-STC transmitter. Similarly, configure the interferer telemetry signal source(s) with independent pseudo noise sequences at the desired bit rate and modulation. Set the center frequencies of these signals to the desired locations above and below the frequency of the victim signal. A good starting point for these signals can be calculated using the adjacent channel interference (ACI) recommendations in IRIG-106 Appendix 2A. Make sure to use the OTA bit rate for the victim when calculating ACI spacing per Appendix 2E.
2. Apply maximum attenuation to the two interferers or mute the RF outputs to remove them from the input to the receiver/decoder. Set the attenuators and noise source level (or adjust the noise and interference test set if available) to produce a BEP of  $1 \times 10^{-5}$  for the victim signal. Increase the power output of the SOQPSK-STC victim signal by 1 dB.
3. Use the spectrum analyzer to set the relative powers of the interfering signal(s). A typical starting point is to have the interfering signal(s) 20 dB larger ( $C/I = -20$  dB) than the victim signal. Vary the attenuator that is common to the two interferers until the BEP is again  $1 \times 10^{-5}$ . Measure the relative power levels of the victim and interferers and record on Data Sheet 9-5.
4. Repeat steps 1 through 3 for various bit rates, modulation types, and center frequencies of the interferer(s) as desired.

9.5.7 Data Reduction. Subtract the victim (C) power level from the interferer (I) power level and record on Data Sheet 9-5.

<b>Data Sheet 9-5. Receiver/Decoder</b>	
<b>Test 9.5</b>	<b>Receiver/Decoder Adjacent Channel Interference</b>
<b>Manufacturer:</b> _____ <b>Model:</b> _____ <b>Serial No:</b> _____ <b>Test Personnel:</b> _____ <b>Date:</b> _____	
Receiver IF Bandwidth _____ MHz Victim: Frequency _____ MHz Bit rate _____ Mbps Power _____ dBm	
Interferer 1: Frequency _____ MHz Bit rate _____ Mbps Modulation type _____ Power _____ dBm Spacing from Victim _____ MHz	
Interferer 2: Frequency _____ MHz Bit rate _____ Mbps Modulation type _____ Power _____ dBm Spacing from Victim _____ MHz	
<b>Power level difference between Victim &amp; Interferer(s), C/I _____ dB</b>	
Receiver IF Bandwidth _____ MHz Victim: Frequency _____ MHz Bit rate _____ Mbps Power _____ dBm	
Interferer 1: Frequency _____ MHz Bit rate _____ Mbps Modulation type _____ Power _____ dBm Spacing from Victim _____ MHz	
Interferer 2: Frequency _____ MHz Bit rate _____ Mbps Modulation type _____ Power _____ dBm Spacing from Victim _____ MHz	
<b>Power level difference between Victim &amp; Interferer(s), C/I _____ dB</b>	
Receiver IF Bandwidth _____ MHz Victim: Frequency _____ MHz Bit rate _____ Mbps Power _____ dBm	
Interferer 1: Frequency _____ MHz Bit rate _____ Mbps Modulation type _____ Power _____ dBm Spacing from Victim _____ MHz	
Interferer 2: Frequency _____ MHz Bit rate _____ Mbps Modulation type _____ Power _____ dBm Spacing from Victim _____ MHz	
<b>Power level difference between Victim and Interferer(s), C/I _____ dB</b>	

## 9.6. TEST: Transmitter 99% Occupied Bandwidth and -25 dBm bandwidth

9.6.1 Purpose. This test measures the 99% OBW and the -25 dBm bandwidth of an SOQPSK-STC telemetry waveform. These bandwidths can be used to determine if the system complies with its spectral occupancy requirements. An example of these bandwidth measurements are shown pictorially in [Figure 9-10](#) for an SOQPSK-STC waveform with a baseband data rate of 5 Mbps (the OTA bit rate is 5.2 Mbps).

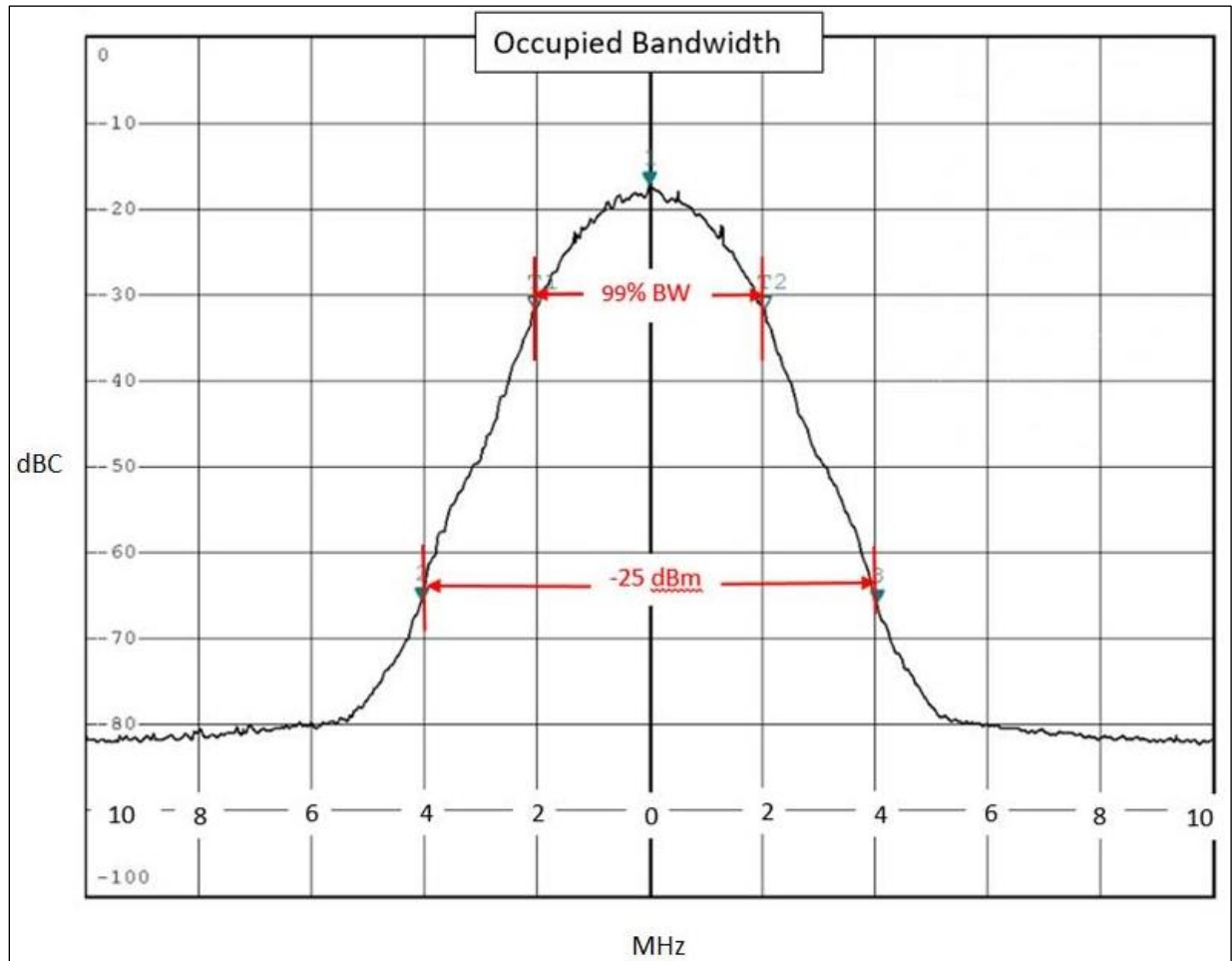

Figure 9-10. OBW Example 5Mbps SOQPSK-STC

9.6.2 Test Equipment. Spectrum analyzer with built-in OBW measurement suite, directional coupler, attenuators, power meter.

9.6.3 Setup. Connect the test equipment as shown in [Figure 9-11](#) for a laboratory test. The attenuator must be set properly in order to keep the input level to the spectrum analyzer below its stated maximum level.

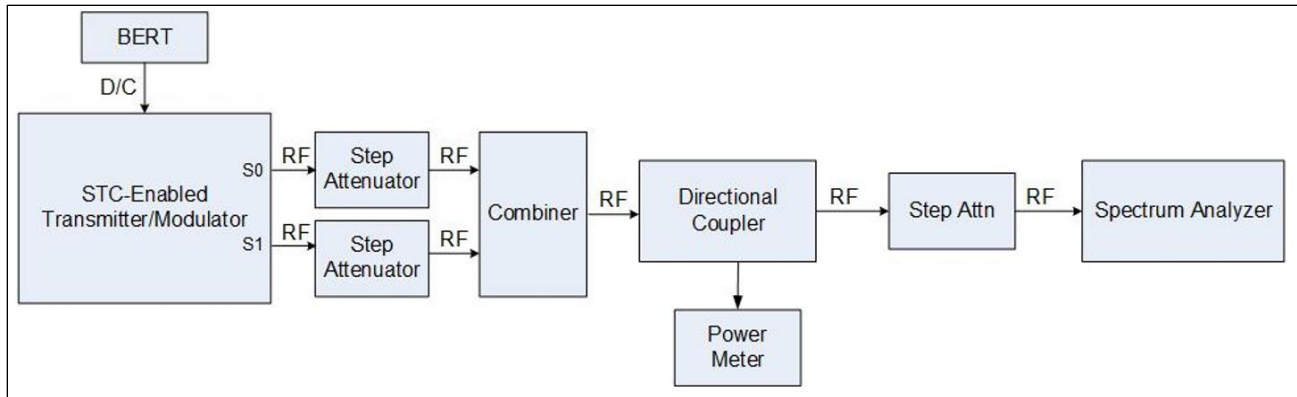

Figure 9-11. Setup for Bandwidth Measurement Test

9.6.4 Conditions. This test is performed with an STC-enabled telemetry transmitter/encoder and a receiver/decoder system hardwired in a laboratory environment. The bandwidth measurements are performed using a spectrum analyzer with the following settings: RBW = 30 kHz, VBW = 300 Hz, peak hold off and averaging off. These settings are consistent with the settings for spectral mask measurements.

#### 9.6.5 Procedure

1. Set the center frequency of the spectrum analyzer to match the transmitter carrier frequency. Adjust the span so all modulated components plus the noise floor of the spectrum analyzer are captured. A good rule of thumb is to have a minimum of one MHz of noise floor captured both above and below the modulated waveform. As a starting point, use four times the bit rate to set the span.
2. If possible, set the telemetry transmitting system to transmit an unmodulated carrier. Take several sweeps with the spectrum analyzer to find the peak value, and set that value as the 0 dBm (0 dBc) reference point (the top of the spectrum analyzer display). The peak value is the unmodulated carrier power at the spectrum analyzer input and will be used as the reference value for the bandwidth measurements.
3. If unmodulated carrier transmission is not possible, find the total carrier power at the input to the spectrum analyzer by setting the analyzer to its maximum RBW and VBW, selecting max (peak) hold, and allowing the analyzer to make several sweeps. The maximum value of the resulting trace will be a good approximation of the unmodulated carrier power for frequency and phase-modulated signals. Set the maximum value as the 0 dBm (0 dBc) reference point (the top of the spectrum analyzer display). An example of this method is shown in [Figure 9-12](#).

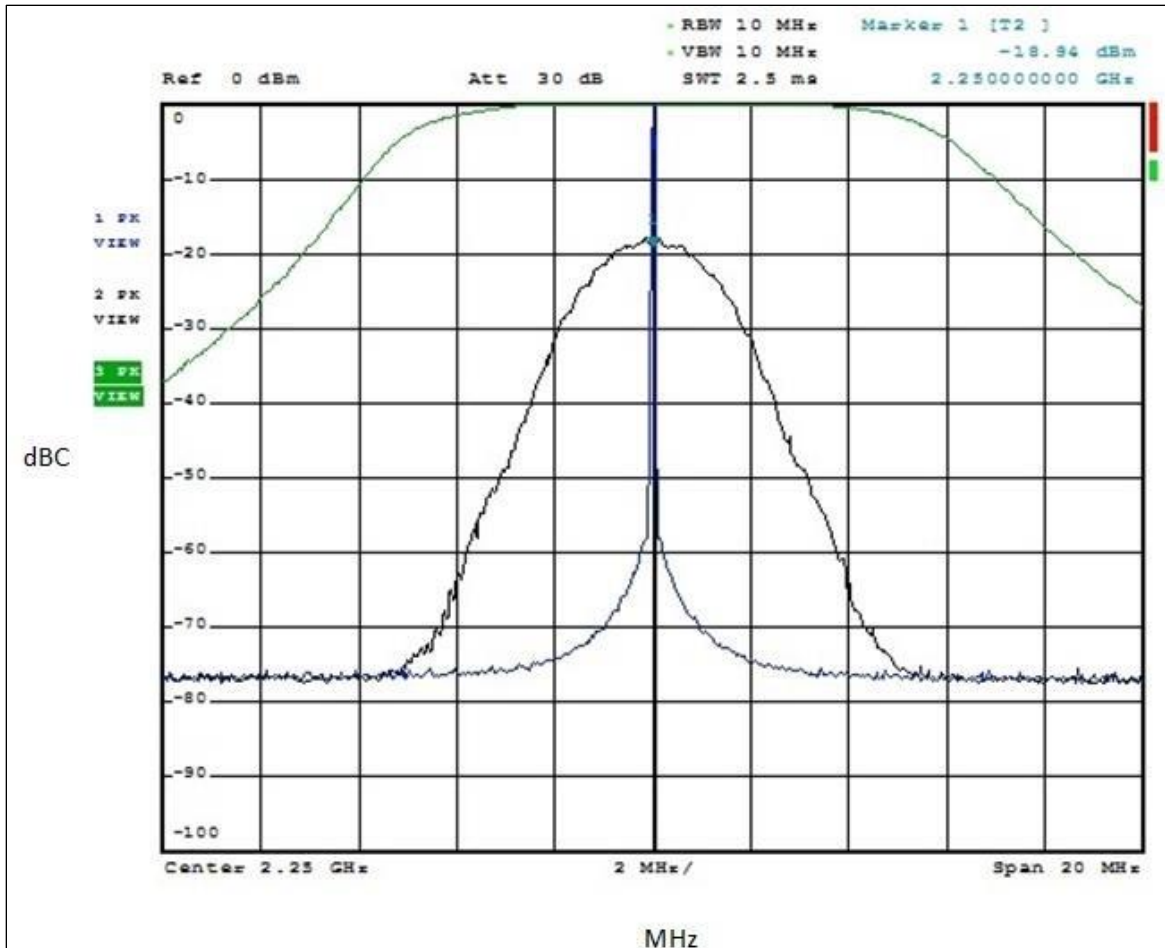

Figure 9-12. Modulated, Unmodulated, and Total Power Estimate Waveforms

4. If possible, make a power measurement with a power meter and record that value in Data Sheet 9-6 after correcting for losses between the transmitting system and the power meter. If a direct power measurement is not possible, record the specified output power of the transmitting system for reference.
5. Configure the spectrum analyzer to the following settings: RBW=30 kHz, VBW=300 Hz, peak hold off, averaging off. Verify the carrier is modulated with SOQPSK-STC modulation. Allow the analyzer to take several sweeps. The span should be set to the recommended width, also verifying that the spectral components decrease to at least  $-70$  dBc. Perform the 99% OBW calculation with the spectrum analyzer. If this measurement cannot be directly measured by the spectrum analyzer, it is possible to capture and download the trace information and determine the frequencies at which 0.5% of the total power is above and below these frequencies. Record the upper and lower frequencies spanning the 99% OBW using Data Sheet 9-6.
6. A power level of  $-25$  dBm is exactly equivalent to an attenuation of the transmitter power by  $55+10\log(P)$  where  $P$  is the transmitter power expressed in watts. For example, the  $-25$  dBm level for a 10-W transmitter is  $-65$  dBc. Find the two frequencies where all spectral components are below the calculated level below the unmodulated carrier level. Record these upper and lower frequencies and the  $-25$  dBm bandwidth using Data Sheet 9-6.

<b>Data Sheet 9-6. 99% Occupied Bandwidth and -25 dBm Bandwidth</b>	
<b>Test 9.6</b>	<b>Transmitter 99% Occupied Bandwidth and -25 dBm Bandwidth</b>
<b>Manufacturer:</b> _____	<b>Model</b> _____ <b>Serial No.</b> _____
<b>Test Personnel</b> _____	<b>Date</b> _____
<b>Center Frequency</b>	_____
Bit Rate	_____
Combined Output Power	_____
<u>99% bandwidth</u>	
Lower Frequency	_____ Upper Frequency _____
99% OBW:	_____ MHz
<u>-25 dBm bandwidth</u>	
Lower Frequency	_____ Upper Frequency _____
<u>-25 dBm bandwidth</u>	_____
Attach photo or plot spectrum:	

## 9.7. TEST: Transmitter Spectral Mask Compliance

9.7.1 Purpose. This test verifies that the output of each RF port of a transmitting system meets the spectral mask as defined in IRIG-106 for SOQPSK-TG with STC encoding.

9.7.2 Test Equipment. BERT, spectrum analyzer, attenuator(s), combiner.

9.7.3 Setup. Connect the test equipment as shown in [Figure 9-13](#). If an external data source is used, ensure the interface settings are matched between the BERT and transmitting system.

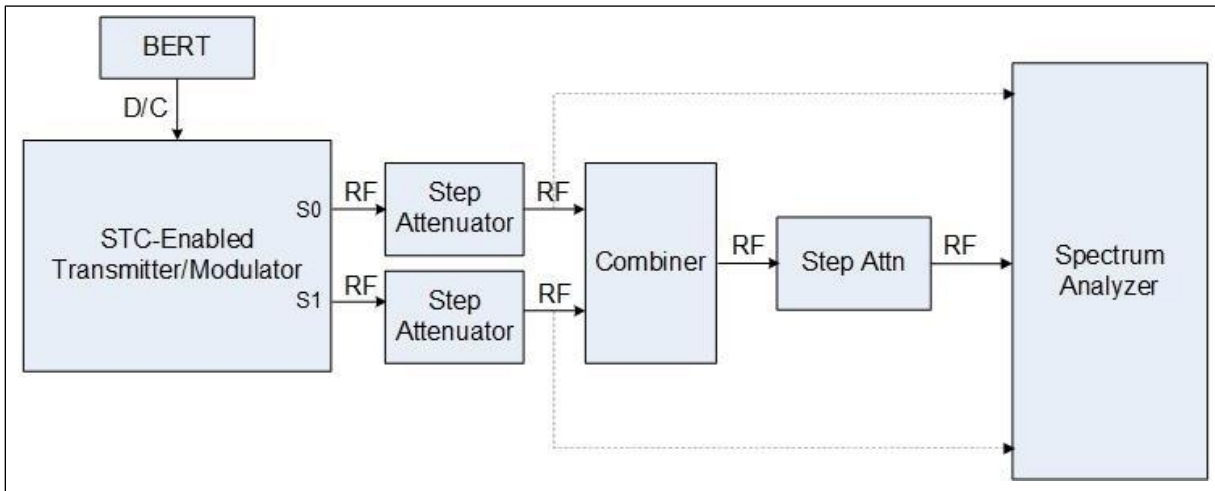

Figure 9-13. Spectral Mask Compliance Setup

9.7.4 Conditions. This test is for verifying that a transmitting system, typically a telemetry transmitter, conforms to the spectral mask as defined in IRIG-106. This test should be performed on the individual channels S0 and S1 and on the combined output. Perform this test under laboratory conditions. The bandwidth measurements are performed using a spectrum analyzer.

### 9.7.5 Procedure

1. The spectrum analyzer should have the following settings.

Center Frequency: Carrier frequency of the transmitting system  
Span: Appropriate for SOQPSK-TG modulation and STC coding.  
RBW = 30 kHz, VBW = 300Hz  
Peak Hold: Off  
Averaging: Off

2. Per [Figure 9-13](#) connect the spectrum analyzer to the RF output to each of the RF ports of the transmitting system through attenuators and combiner rated for the power of the transmitting system with enough attenuation to protect the input to the spectrum analyzer. A value of 40 dB of attenuation is typical for a 10-W transmitter but the correct value should be determined based upon the output power of the transmitter and maximum input level to the spectrum analyzer. If using a BERT, connect it to the transmitting system at the desired rate (clock frequency) and data pattern. Another method is to use the internal clock and data pattern generator of the transmitter to provide baseband data.

3. Place each RF port on the transmitter to carrier-only mode either by an input data pattern of alternating 1s and 0s or via an external serial interface that controls each transmitter directly. Once in carrier-only mode, measure the output power (carrier power) for each and record it on Data Sheet 9-7. Be sure to account for the attenuation between the transmitting system and spectrum analyzer. This will be the 0 dBc value. Alternatively, adjust the attenuation so that the peak of the carrier is at the 0 dBm level of the spectrum analyzer. Once this is done for each RF port, the amplitude on the spectrum analyzer and in the spectrum capture file can be read directly as dBc. (Note: 0 dBc values between RF ports should be nearly identical.)
4. For each RF port (S0 and S1 of the transmitting system), set the data source to the required pseudo noise data pattern. Longer patterns are more representative of encrypted data. Set the modulation mode to SOQPSK-STC at the bit rate of choice. Measure and capture the transmitted waveform with the spectrum analyzer and record the results on Data Sheet 9-7. If 0 dBc was set, the amplitude will read in dBc directly. If not, convert the captured data to dBc by subtracting the measured carrier power from measured amplitude values. Repeat the procedure for the combined output and record on Data Sheet 9-7.
5. Compare the measured values with the spectral mask for SOQPSK-TG modulation. The spectral masks are published in IRIG-106 Appendix 2-A. The bit rate required for the mask calculation must be adjusted for STC (an expansion factor of 26/25). This bandwidth expansion factor can be found in 106-22 Appendix 2-E addressing STC coding.



Data Sheet 9-7. Transmitter/Encoder Spectral Mask						
<b>Test 9-7</b>		<b>Transmitter/Encoder Spectral Mask Compliance</b>				
<b>Manufacturer:</b> _____			<b>Model:</b> _____			
<b>Serial No:</b> _____						
<b>Test Personnel:</b> _____			<b>Date:</b> _____			
Center Frequency: _____ MHz		Output Power: _____ W				
Bit rate: _____ Mbps		“Over the Air” Bit Rate: _____ Mbps				
Frequency (Hz)	Level (dBm)			Level (dBc)		
	S0	S1	Combiner	S0	S1	Combiner
Carrier						
Carrier – Bit Rate						
Carrier – 0.9*Bit Rate						
Carrier – 0.8*Bit Rate						
Carrier – 0.7*Bit Rate						
Carrier – 0.6*Bit Rate						
Carrier – 0.5*Bit Rate						
Carrier						
Carrier + 0.5*Bit Rate						
Carrier + 0.6*Bit Rate						
Carrier + 0.7*Bit Rate						
Carrier + 0.8*Bit Rate						
Carrier + 0.9*Bit Rate						
Carrier + Bit Rate						

## 9.8. TEST: STC-Enabled Transmitter/Encoder to Receiver/Decoder Interoperability

9.8.1 Purpose. This test verifies end-to-end operation of an STC-enabled telemetry system. Either the transmitter/encoder or the receiver/decoder can be verified if one has already been verified as correctly encoding (for the transmitter/encoder) or decoding (for the receiver/decoder).

9.8.2 Test Equipment. BER test set, spectrum analyzer, attenuator(s), power dividers (2).

9.8.3 Setup. Connect the transmitter/encoder, receiver/decoder, and test equipment as shown in [Figure 9-14](#).

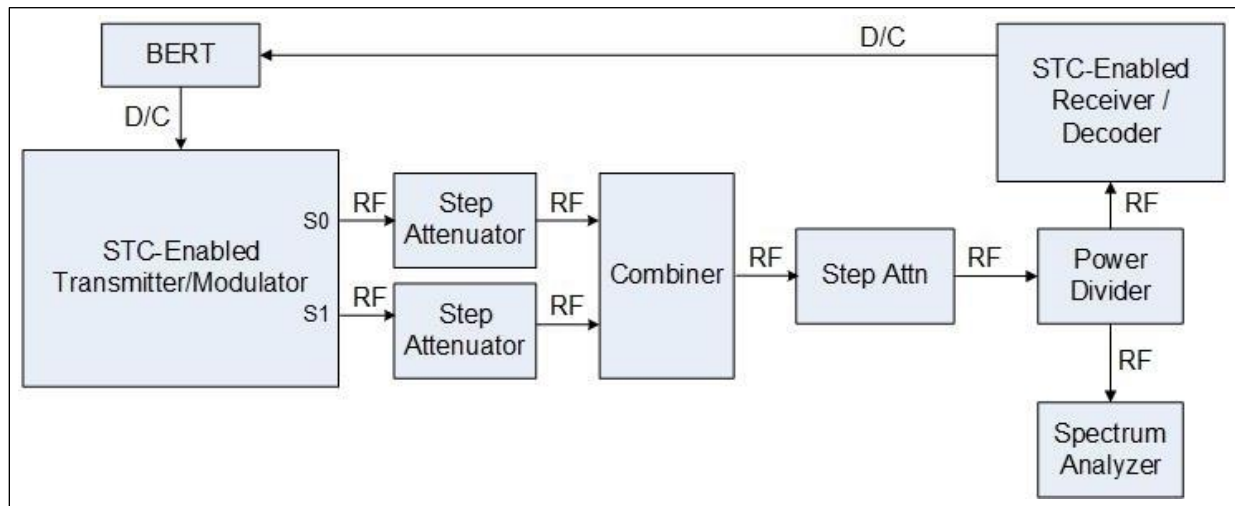

Figure 9-14. Transmitter/Encoder to Receiver/Decoder Interoperability Test Setup

9.8.4 Conditions. This test is intended to be conducted in a laboratory environment.

### 9.8.5 Procedure

1. Set the BERT to generate a pseudo noise pattern of at least  $2^{11}-1$  (PRN11), preferably longer to better simulate encrypted data, at the bit rate required for the test. With the RF muted, configure the transmitting system for the proper carrier frequency, SOQPSK-STC modulation, and required bit rate from the BERT. Enable the proper randomizer for STC per IRIG-106.
2. Set the attenuator levels so the receiver/decoder is operating well within its linear range. A typical value for a telemetry receiver/decoder would be an input level of  $-40$  dBm. Configure the receiver/decoder for the matching center frequency, SOQPSK-STC modulation, data rate, and derandomizer. Unmute the RF output on the transmitting system and verify the receiver/decoder is receiving, demodulating, and decoding the signal. Verify the BERT detector synchronizes on the proper data pattern. If available on the receiver/decoder, verify that both S0 and S1 are present, and there are no differential delay or amplitude differences in the received signal.
3. Once the BERT synchronizes, monitor the number of errors over a 15-minute interval. Record the number of errors the BERT counts over this 15-minute interval on Data Sheet 9-8.

<b>Data Sheet 9-8. Transmitter/Encoder to Receiver/Decoder</b>	
<b>Test 9-8</b>	<b>Transmitter/Encoder to Receiver/Decoder Interoperability</b>
<b>Manufacturer:</b> _____	<b>Model:</b> _____
<b>Serial No.:</b> _____	
<b>Test Personnel:</b> _____	<b>Date:</b> _____
Center frequency: _____ MHz	Output Power: _____ W
Data Pattern: _____	
Bit rate: _____ Mbps	Over the Air Bit Rate: _____ Mbps
Bit Errors/15 Minute Interval: _____	

## 9.9. TEST: STC Signals with RF Combining

9.9.1 **Purpose.** This test determines the combiner's performance with different relative amplitude levels of S0 and S1 at each of the receiver/combiner channels. With a valid input to the receiver, the combiner should always have a valid output.

9.9.2 **Test Equipment.** STC transmitter/encoder or simulator, receiver/combiner, BERT, voltage-controlled attenuators, voltage source with amplitude modulation, receiver/decoder.

9.9.3 **Setup.** Connect the STC transmitter/encoder with the attenuators, combiners, and splitters as shown in [Figure 9-15](#).

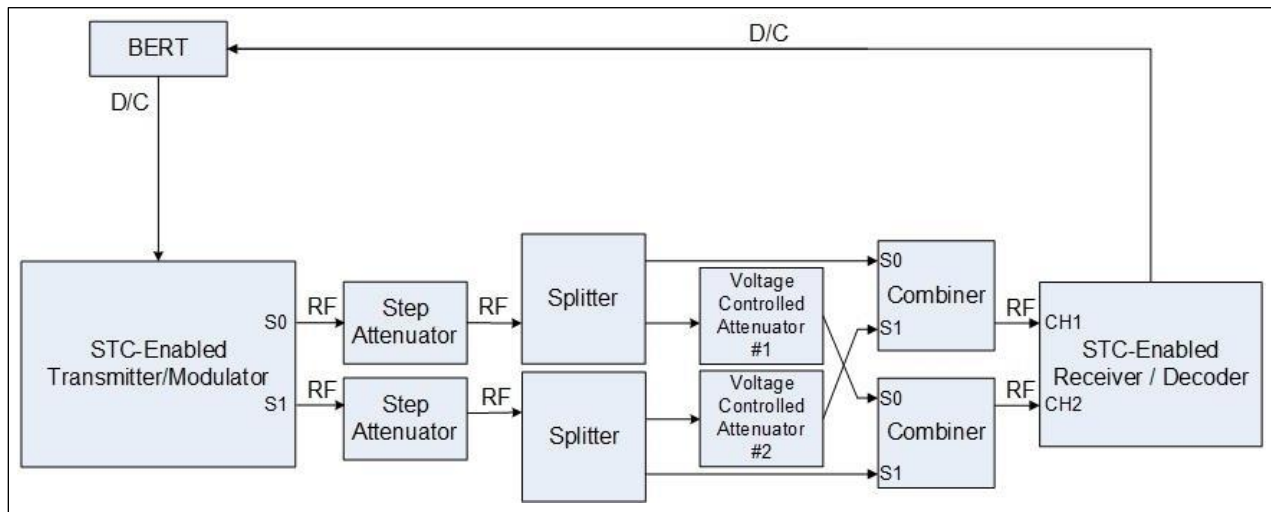

Figure 9-15. Combiner Test Configuration

### 9.9.4 Procedure

1. Connect the equipment as in [Figure 9-15](#). Set the step attenuators to provide equal power levels of S0 and S1 at a combined level of  $-40$  dBm to both CH1 and CH2 of the receiver/decoder. Set the voltage-controlled attenuators to minimum attenuation. Verify the receiver/decoder is performing RF/IF combining. Verify the receiver/decoder is properly demodulating the two STC signals and the combiner is providing data to the BERT without errors. If available on the receiver/decoder, verify that both S0 and S1 are present, and there are no differential delay or amplitude differences in the received signal. Verify the combiner is functioning properly with the display.
2. While monitoring the receiver/decoder front panel or client software, decrease the S1 power level on CH1 by increasing the attenuation of voltage-controlled step attenuator #2 in 10-dB steps until the S0 amplitude is 30 dB larger than the S1 amplitude on channel 1. Verify no errors on the combiner output. Record results in Data Sheet 9-9.
3. While monitoring the receiver/decoder front panel or client software, decrease the S0 content on CH2 by increasing the attenuation of voltage-controlled step attenuator #1 in 10-dB steps until the S1 amplitude is 30 dB larger than the S0 amplitude on channel 2. Verify no errors on the combiner output. Record results in Data Sheet 9-9.
4. Repeat steps 1 through 3 for other bit rates as desired.

<b>Data Sheet 9-9. STC Signals</b>			
<b>Test 9.9</b>		<b>STC Signals with RF Combining</b>	
<b>Manufacturer:</b> _____		<b>Model:</b> _____	
<b>Serial No:</b> _____			
<b>Test personnel:</b> _____		<b>Date:</b> _____	
<b>Center Frequency (MHz)</b>			
	<b>Voltage Controlled Attenuator #1 (Reduces S0 on CH2) (dB)</b>	<b>Voltage Controlled Attenuator #2 (Reduces S1 on CH1) (dB)</b>	<b>COMBINER BEP</b>
	0	0	
	0	-10	
	0	-20	
	0	-30	
	-10	-30	
	-20	-30	
	-30	-30	

This page intentionally left blank.

## CHAPTER 10

### Test Procedures for Implementing Multipath Channel Conditions

#### 10. General

The following test methods can be used to implement the IRIG 106 telemetry channel model<sup>10</sup> to test telemetry system components in the presence of multipath and assess multipath sensitivity. Some testing examples include comparing modulation scheme performance, assessing coding gain, characterizing equalizer gain, etc., all through the IRIG 106-compliant multipath channel.

Derived from the initial channel modeling work,<sup>11</sup> the telemetry channel is defined in 106-22 Appendix 2H with definitions for the parameters in Equations 1 and 2. The impulse response of the channel can be expressed both as a static channel (Equation 1) and dynamic channel (Equation 2). The difference in the two is the time-varying nature of the dynamic channel.

$$h(t) = \delta(t) + \Gamma_1 e^{-j2\pi f_c \tau_1} \delta(t - \tau_1) + \Gamma_2 e^{-j2\pi f_c \tau_2} \delta(t - \tau_2). \quad (\text{Eq. 10-1})$$

$$h(t) = \delta(t) + \Gamma_1(t) e^{-j2\pi f_c \tau_1(t)} \delta(t - \tau_1(t)) + \Gamma_2(t) e^{-j2\pi f_c \tau_2(t)} \delta(t - \tau_2(t)) \quad (\text{Eq. 10-2})$$

These two channel definitions are used within this test method. Both will be used to test the multipath susceptibility of the SUT under fixed and dynamic channel conditions. The channels can be completely defined with the reflection coefficients ( $\Gamma_1$ ,  $\Gamma_2$ ), relative delays ( $\tau_1$ ,  $\tau_2$ ), carrier frequency ( $f_c$ ), and vehicle speed. (Note: There is also a phase shift,  $\gamma_1$  and  $\gamma_2$  associated with each reflection coefficient where  $\Gamma_1 = |\Gamma_1| e^{j\gamma_1}$  and  $\Gamma_2 = |\Gamma_2| e^{j\gamma_2}$ .) Each channel parameter is relative to the LOS direct path  $\delta(t)$ , which has unity gain and zero delay. Specular and diffuse delays  $\tau_1$  and  $\tau_2$  are usually expressed in time relative to the LOS path.

If a channel emulator is used during this testing, the telemetry channel can be created using three propagation paths within the emulator. Path 1 is the LOS path, Path 2 is the specular reflection path, and Path 3 is the diffuse reflection path. The emulator then sums these paths to create one composite path through the emulator.

#### **Static Channel Conditions**

Static channel conditions are broken into two test conditions based upon the number of propagation paths (i.e., transmission rays). The static 3-ray channel defines three channels with differing severity based upon the characteristics of the specular and diffuse reflections. The static 2-ray channel defines a test matrix of multiple configurations of  $\Gamma_1$ ,  $\tau_1$ , and  $\gamma_1$  that define the specular reflection. The multiple-channel test matrix simplifies the 3-ray static channel by using only the specular reflection component but defines many more static channel conditions. The multiple test conditions of the 2-ray case lends itself to automated testing.

---

<sup>10</sup> Range Commanders Council. "Dynamic Multipath Channel Model for Aeronautical Mobile Telemetry." Appendix 2H in *Telemetry Standards*. RCC 106-22. May 2022. May be superseded by update. Retrieved 13 May 2022. Available at <https://www.trmc.osd.mil/wiki/x/EoPOBg>

<sup>11</sup> Rice, M., A. Davis, and C. Bettweiser. "Wideband Channel Model for Aeronautical Telemetry." In *IEEE Transactions on Aerospace and Electronic Systems*, vol. 40, no. 1, pp. 57-69, January 2004.

For the static channel conditions, the phase  $\gamma_1$  for the specular reflection term is referenced to a null placed at the carrier frequency and then offset from that value. The phase value  $\gamma_1$  is stated in terms of delay ( $\tau_1$ ) and multiples ( $r$ ) of the bit rate ( $R_b$ ) for the waveform under test as shown in Equation 10-3. This places the multipath null created by the second ray at a fixed value from the carrier frequency in terms of the bit rate. This ensures the channel condition will affect the modulated signal.

$$\gamma_1 = 180^\circ \pm (360^\circ)\tau_1 r R_b. \quad (\text{Eq. 10-3})$$

For example, given a specular reflection delay of 50 nanoseconds (ns), it is desired to have  $r = 0.2$  for  $R_b = 5$  Mbps resulting in the specular reflection null placed  $rR_b = 1$  MHz away from the carrier frequency. For this specular delay, the null cycles through  $360^\circ$  every 20 MHz (1/50 ns) or at a rate of  $18^\circ/\text{MHz}$ . The phase setting can then be calculated to be  $180^\circ \pm 18^\circ = 162^\circ$  or  $198^\circ$ .

### Static 3-ray Channels

#### 1. Channel 1 – Mild Impairment

Specular Reflection Term:  $\Gamma_1 = -3.0$  dB,  $\tau_1 = 50$  ns,  $r = 0.55$

Diffuse Reflection Term:  $\Gamma_2 = -20$  dB,  $\tau_2 = 155$  ns,  $\gamma_2 = 90^\circ$

#### 2. Channel 2 – Moderate Impairment

Specular Reflection Term:  $\Gamma_1 = -1.5$  dB,  $\tau_1 = 50$  ns,  $r = 0.1$

Diffuse Reflection Term:  $\Gamma_2 = -20$  dB,  $\tau_2 = 155$  ns,  $\gamma_2 = 90^\circ$

#### 3. Channel 3 – Severe Impairment

Specular Reflection Term:  $\Gamma_1 = -1.0$  dB,  $\tau_1 = 50$  ns,  $r = 0$

Diffuse Reflection Term:  $\Gamma_2 = -20$  dB,  $\tau_2 = 155$  ns,  $\gamma_2 = 90^\circ$

### Static 2-ray Channel - Test Matrix

Settings for Specular Reflection Term:

$\Gamma_1 = -3$  dB,  $-2.5$  dB,  $-1.5$  dB,  $-1$  dB,  $-0.5$  dB

$\tau_1 = 50$  ns,  $100$  ns,  $150$  ns

$r = 1$  to  $0$  in  $0.1$  steps

### Dynamic Channel Conditions

In order to set the proper values for the specular and diffuse reflections for the dynamic channel, some introduction is required. The dynamic specular reflection term can be approximated by

$$\Gamma_1(t)e^{-j2\pi f_c \tau_1(t)} \delta(t - \tau_1(t)) \approx |\Gamma_1| e^{-j(2\pi f_d t + \theta_1)} \delta(t - \tau_1(t)) \quad (\text{Eq. 10-4})$$

The term to note in Equation 10-4 is the Doppler frequency,  $f_d$  which is the rate of change of the phase of the specular reflection.





The Doppler frequency should not be confused with the Doppler shift. The Doppler shift is a change in frequency caused by motion of the transmitter and is proportional to the radial velocity component of the transmitter as observed from the ground station. The Doppler frequency is a parameter that in general measures how rapidly the multipath channel is changing.

Here the Doppler frequency states how fast the phase of the specular reflection is changing. This term produces a time variation of the spectral null caused by this reflection term.<sup>12</sup> This term must be accounted for in the specular reflection component within the channel emulator. The Doppler frequency scales as vehicle velocity and/or carrier frequency changes. For example, for a vehicle speed of 660 knots,  $f_d = 3 \times 10^{-11} * f_c$  where  $f_c$  is the carrier frequency (106-22 Appendix 2H, Rice and Ebert). The factor relating the Doppler frequency  $f_d$  to carrier frequency  $f_c$  is termed the Doppler Frequency Factor. This factor scales with vehicle velocity. For example, as velocity doubles, the factor doubles. If velocity is halved, the factor is halved and so on. [Table 10-1](#) provides these values for several typical vehicle speeds.

Velocity	Factor
330 knots	$1.5 \times 10^{-11}$ s/s
660 knots	$3 \times 10^{-11}$ s/s
1320 knots	$6 \times 10^{-11}$ s/s

The dynamic diffuse reflection term has statistical characterizations for  $\Gamma_2(t)$  and  $\tau_2(t)$  (106-22 Appendix 2H). This test method assumes that  $\tau_2(t)$  is fixed at its average value. The amplitude distribution of  $\Gamma_2(t)$  can be approximated by a Rayleigh random process with a power spectral density given by

$$S_2(f) = \frac{\sqrt{2}}{B_{rms}\sqrt{\pi}} \exp\left\{-2\left(\frac{f}{B_{rms}}\right)^2\right\} \quad (\text{Eq. 10-5})$$

The term to note in Equation 10-5 is the fading Doppler spread,  $B_{rms}$ , which is a function of the carrier frequency and vehicle speed as shown in [Table 10-2](#). If the channel emulator is not equipped to generate a random process with the proper power spectral density (Equation 10-5), it is important that the channel emulator implement a good approximation of this random process. One example of approximating the fading spectrum shape is in 106-22 Appendix 2H. [Table 10-2](#) shows several values of  $B_{rms}$  for typical vehicle speeds and generalizes carrier frequency to the L/S/C telemetry bands.

Velocity	L-Band	S-Band	C-Band
330 knots	0.66 Hz	1.00 Hz	2.26 Hz
660 knots	1.32 Hz	2.00 Hz	4.52 Hz
1320 knots	2.64 Hz	4.00 Hz	9.04 Hz

<sup>12</sup> Rice, M. and J. Ebert. "Derivation and Analysis of the IRIG-106 Dynamic Multipath Channel Model." In *Proceedings of the International Telemetry Conference*, Glendale, AZ, 26-29 October 2020.

Dynamic Channel 1 (Over Land)

LOS (Path 1):  $\Gamma_0 = 0$  dB,  $\tau_0 = 0$ ,  $\gamma_0 = 0^\circ$

Specular Reflection Term (Path 2):  $\Gamma_1 = -0.5$  dB,  $\tau_1 = 10$  ns,  $\gamma_1 = 0^\circ$ ,  $f_d$  (calculate the rate of frequency shift)

Diffuse Reflection Term (Path 3):  $\Gamma_2 = -20$  dB,  $\tau_2 = 155$  ns,  $\gamma_2 = 0^\circ$ ,  $B_{rms}$  (calculate fading Doppler spread value), fading spectrum amplitude distribution (approximate Rayleigh fading), fading spectrum shape (approximate Gaussian power spectral density)

Dynamic Channel 2 (Over Water, Calm Sea State)

LOS (Path 1):  $\Gamma_0 = 0$  dB,  $\tau_0 = 0$ ,  $\gamma_0 = 0^\circ$

Specular Reflection Term (Path 2):  $\Gamma_1 = -1.7$  dB,  $\tau_1 = 35$  ns,  $\gamma_1 = 0^\circ$ ,  $f_d$  (calculate the rate of frequency shift)

Diffuse Reflection Term (Path 3):  $\Gamma_2 = -12.2$  dB,  $\tau_2 = 69$  ns,  $\gamma_2 = 0^\circ$ ,  $B_{rms}$  (calculate fading Doppler spread value), fading spectrum amplitude distribution (approximate Rayleigh fading), fading spectrum shape (approximate Gaussian power spectral density)

Dynamic Channel 2 (Over Water, Rough Sea State)

LOS (Path 1):  $\Gamma_0 = 0$  dB,  $\tau_0 = 0$ ,  $\gamma_0 = 0^\circ$

Specular Reflection Term (Path 2):  $\Gamma_1 = -2.8$  dB,  $\tau_1 = 25$  ns,  $\gamma_1 = 0^\circ$ ,  $f_d$  (calculate the rate of frequency shift)

Diffuse Reflection Term (Path 3):  $\Gamma_2 = -10.5$  dB,  $\tau_2 = 54$  ns,  $\gamma_2 = 0^\circ$ ,  $B_{rms}$  (calculate fading Doppler spread value), fading spectrum amplitude distribution (approximate Rayleigh fading), fading spectrum shape (approximate Gaussian power spectral density)

This test method is intended to test the multipath sensitivity of the SUT under various multipath conditions. It is not meant to characterize this performance in channels with high levels of additive noise. To reflect this and typical far-flight scenarios, the energy per bit to noise spectral density ratio  $E_b/N_0$  of the signal prior to being exposed to the channel condition shall be 20 dB.  $E_b/N_0$  is defined in terms of the carrier-to-noise ratio  $C/N$  by the relationship  $E_b/N_0 = (C/N)(B/R_b)$  where  $B$  is the bandwidth in which  $C/N$  is measured and  $R_b$  is the bit rate. It is understood that during the testing the instantaneous  $E_b/N_0$  will vary from the initial value of 20 dB as seen by the receiver/equalizer. [Table 10-3](#) lists tests in this chapter and their corresponding section numbers.

<b>Table 10-3. Test Matrix for System Testing</b>	
<b>Test Number</b>	<b>Test Description</b>
<a href="#">10.1</a>	System Bit Error Rate for Static 3-ray Channels

<a href="#">10.2</a>	System Bit Error Rate for Static 2-ray Channels
<a href="#">10.3</a>	System Link Availability for Dynamic Channel 1
<a href="#">10.4</a>	System Link Availability for Dynamic Channel 2

### 10.1. TEST: System Bit Error Rate for Static 3-ray Channels

10.1.1 Purpose. This test assesses the multipath sensitivity of the SUT measured in terms of overall BER in three static multipath channels.

10.1.2 Test Equipment. There are three methods available for generating static multipath channels. The first is with a selection of RF components; the second is with a channel emulator; and the third is with a receiver analyzer manufactured specifically to perform this test. To simplify the testing, it is recommended that either a channel emulator or receiver analyzer is used for this test.

- Channel emulator method: Bit error test set, modulator (e.g. telemetry transmitter, I/Q signal source, etc.), noise test set, channel emulator, receiver under test, spectrum analyzer
- Receiver Analyzer method: Receiver analyzer, bit error test set (if required), receiver under test, spectrum analyzer
- Fixed RF Component method: Bit error test set, modulator (e.g., telemetry transmitter, I/Q signal source, etc.), method for setting signal  $E_b/N_0$ , delay lines, step attenuator (in 0.1-dB steps), phase shifters, power dividers/combiners, receiver under test, spectrum analyzer

10.1.3 Setup (using a channel emulator). This method places the channel emulator between the signal source and the receiver under test. The channel emulator allows direct control over the channel parameters ( $\Gamma_1$ ,  $\tau_1$ ,  $\Gamma_2$ ,  $\tau_2$ , and  $\gamma_1$ ,  $\gamma_2$ ) for each of the 3-rays used to create the fixed multipath conditions. A noise test set is also used to fix a value of  $E_b/N_0$  for the test signal prior to being subjected to multipath by the channel emulator as shown in [Figure 10-1](#).

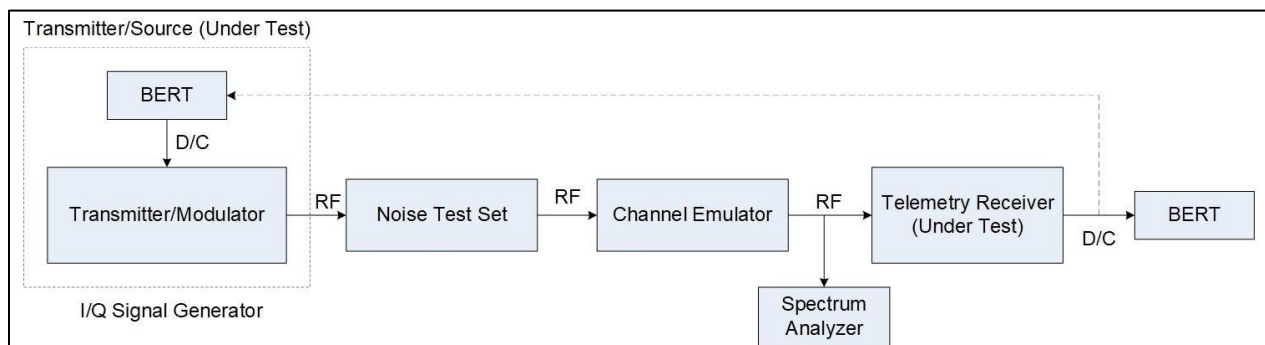

Figure 10-1. Setup using Channel Emulator for 3-Ray Static Multipath Test

10.1.4 Setup (using receiver analyzer). This method uses a receiver analyzer to create both the desired waveform and the static channel conditions in one unit, as shown in [Figure 10-2](#). The output of the receiver analyzer is the waveform with the static channel condition already applied. As with the channel emulator, direct control over the channel parameters ( $\Gamma_1$ ,  $\tau_1$ ,  $\Gamma_2$ ,  $\tau_2$ , and  $\gamma_1$ ,  $\gamma_2$ ) for each of the 3-rays is available within the receiver analyzer.

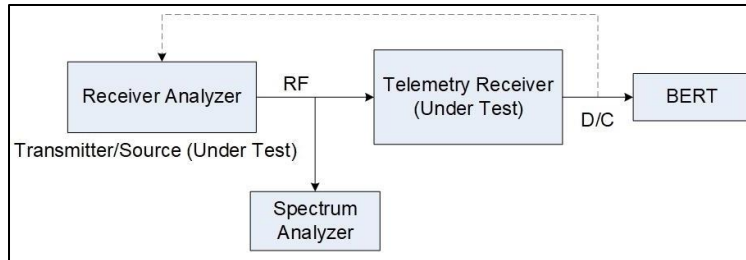

Figure 10-2. Setup using Receiver Analyzer for 3-Ray Static Multipath Test

10.1.5 **Setup (using discrete RF components).** This method uses discrete components to derive the multipath channel condition for this test, as shown in [Figure 10-3](#). Attenuators are used for setting  $\Gamma_1$  and  $\Gamma_2$ , delay lines for  $\tau_1$  and  $\tau_2$ , and phase shifters for  $\gamma_1$  and  $\gamma_2$ . Power dividers/combiners are required to divide the generated signal into 3 paths and to sum the three rays after the multipath conditions are applied.

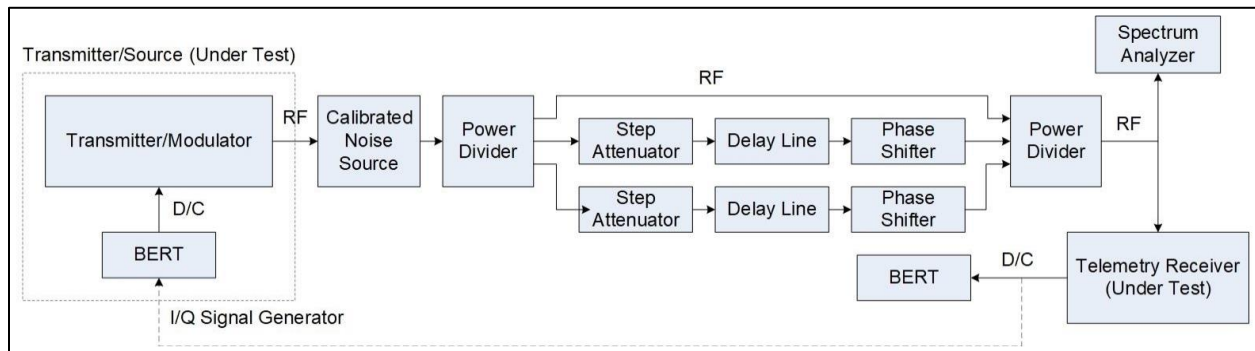

Figure 10-3. Setup using Discrete RF Components for 3-Ray Static Multipath Test

10.1.6 **Conditions.** This test can be performed using one of the following: A waveform signal source; a method to set signal  $E_b/N_0$  plus discrete RF components to create the multipath channel conditions; a waveform signal source; noise test set to set signal  $E_b/N_0$  plus a channel emulator to create the multipath channel conditions; or a receiver analyzer that allows control over the waveform, additive noise, and 3-ray multipath channel condition.

#### 10.1.7 Procedure

1. Set the bit error test set or source pattern to generate the desired bit rate with a pseudo-noise bit sequence length of at least  $2^{11}-1$  bits and preferably  $2^{31}-1$  bits long (the longer sequence is a better simulation of the characteristics of an encrypted baseband signal). Set the signal source to generate the required modulation scheme and coding scheme (if required) at the chosen carrier frequency. (If available, amplify the signal with a non-linear amplifier). As a quick check, use a spectrum analyzer to verify the signal spectrum matches the expected modulated waveform. If a receiver analyzer is used, then the BERT pattern, bit rate, carrier frequency, and modulation and coding schemes are set in this one unit.
2. Using the noise test set (or by other means), set  $E_b/N_0 = 20$  dB for the OTA bit rate. If using the channel emulator, set the output level of the noise test set to match the input level required for the channel emulator. Set  $E_b/N_0 = 20$  dB directly within the receiver analyzer.
3. Set the receiver to match the combination of bit rate, carrier frequency, and modulation/coding scheme chosen for the test. Connect the BERT to the output of the receiver.

4. Connect the modulator/noise test set to the receiver through either the channel emulator or discrete RF components. If using a receiver analyzer, directly connect it to the receiver. To verify end-to-end connection between the modulator and receiver, configure only the LOS direct path. If using RF components, this is as simple as connecting the modulator and receiver together with a coaxial cable. If using a channel emulator, enable the LOS path (Path 1) with unity gain, zero delay, and zero phase shift. If using a receiver analyzer, disable the multipath function. Verify that the bit error test set synchronizes on the correct pseudo-noise bit sequence.
5. Connect the remainder of the discrete RF components to create the specular and diffuse reflections creating the composite 3-ray multipath channel. If using a channel emulator, enable the specular (Path 2) and diffuse (Path 3) reflections. If using a receiver analyzer, enable the multipath function
6. Configure the multipath setup for mild impairment as defined above for the Static 3-ray Channel. Measure the resulting BER for this channel condition. Record this value of BER on the data sheet.
7. Repeat for the moderate and severe static 3-ray channel conditions. Vary bit rate, modulation and coding scheme, and carrier frequency as appropriate. Allow BER to stabilize. Record the resulting BER values for each test set up in the data sheet.

10.1.8 Data Reduction. Each BER result is a measure of the multipath sensitivity of the SUT. If performing more than one test, compare the measured BER for each test under each 3-ray channel condition. For each test, a smaller value of BER means less multipath sensitivity for that static multipath channel condition. The results can be plotted and compared using a column or bar chart of system setup (modulation/coding scheme, data rate, carrier frequency) versus BER. Another method of presenting the results is to calculate or capture the data quality metric (DQM) values from the receiver (if available) and use DQM instead of BER.

<b>Data Sheet 10-1. System Bit Error Rate for Static 3-ray Channels</b>																																																																		
<b>Test 10.1</b>	<b>Receiver/Equalizer BER for Static 3-ray Channels</b>																																																																	
Manufacturer:	Model:																																																																	
Serial No.:																																																																		
Test Personnel:	Date:																																																																	
Center frequency: _____ MHz      Time per Point: _____																																																																		
<table border="1" style="width: 100%; border-collapse: collapse; text-align: center;"> <thead> <tr> <th style="width: 25%;">Static 3-ray Channel Condition</th> <th style="width: 25%;">Modulation</th> <th style="width: 25%;">Bit Rate (Mbps)</th> <th style="width: 25%;">Coding</th> <th style="width: 20%;">BER/DQM</th> </tr> </thead> <tbody> <tr><td> </td><td> </td><td> </td><td> </td><td> </td></tr> <tr><td> </td><td> </td><td> </td><td> </td><td> </td></tr> <tr><td> </td><td> </td><td> </td><td> </td><td> </td></tr> <tr><td> </td><td> </td><td> </td><td> </td><td> </td></tr> <tr><td> </td><td> </td><td> </td><td> </td><td> </td></tr> <tr><td> </td><td> </td><td> </td><td> </td><td> </td></tr> <tr><td> </td><td> </td><td> </td><td> </td><td> </td></tr> <tr><td> </td><td> </td><td> </td><td> </td><td> </td></tr> <tr><td> </td><td> </td><td> </td><td> </td><td> </td></tr> <tr><td> </td><td> </td><td> </td><td> </td><td> </td></tr> <tr><td> </td><td> </td><td> </td><td> </td><td> </td></tr> <tr><td> </td><td> </td><td> </td><td> </td><td> </td></tr> </tbody> </table>		Static 3-ray Channel Condition	Modulation	Bit Rate (Mbps)	Coding	BER/DQM																																																												
Static 3-ray Channel Condition	Modulation	Bit Rate (Mbps)	Coding	BER/DQM																																																														

## 10.2. TEST: System Bit Error Rate for Static 2-ray Channels

10.2.1 Purpose. This test assesses the multipath sensitivity of the SUT, measured in terms of overall BER, when subjected to multiple 2-ray static multipath channels.

10.2.2 Test Equipment. There are three methods available for generating static multipath channels. The first method is with a selection of RF components. Given the multiple combinations of amplitude, delay, and phase of the specular component (Path 2) for each bit rate or carrier frequency for this test, performing this test with individual RF components is not recommended. The second method is with a channel emulator, and the third is with a receiver analyzer (if the unit is capable of performing this testing). It is recommended that either a channel emulator or receiver analyzer is used for this test.

- Channel emulator method: Bit error test set, modulator (e.g. TM transmitter, I/Q signal source, etc.), noise test set, channel emulator, receiver under test, spectrum analyzer
- Receiver Analyzer method: Receiver analyzer, bit error test set (if required), receiver under test, spectrum analyzer
- Fixed RF Component method (not recommended): Bit error test set, modulator (e.g., TM transmitter, I/Q signal source, etc.), method for setting signal  $E_b/N_0$ , delay lines, step attenuator (in 0.1-dB steps), phase shifters, power dividers/combiners, receiver under test, spectrum analyzer

10.2.3 Setup (using a channel emulator). This method places the channel emulator between the signal source and the receiver, as shown in [Figure 10-4](#). The channel emulator allows direct control over the channel parameters ( $\Gamma_1$ ,  $\tau_1$ ,  $r$ , or  $\gamma_1$ ) that create the multiple 2-ray multipath conditions. A noise test set is also used to set a fixed value of  $E_b/N_0$  for the test signal prior to being subjected to multipath by the channel emulator.

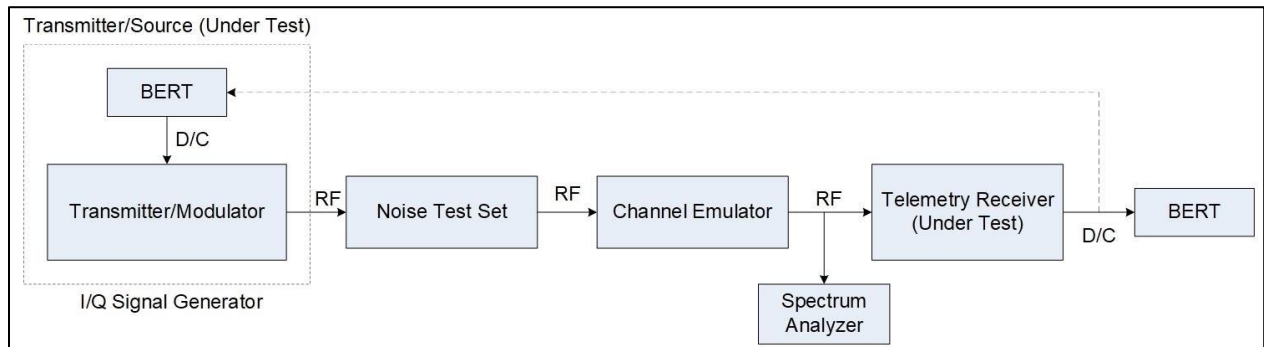

Figure 10-4. Setup using Channel Emulator for 2-ray Static Multipath Test

10.2.4 Setup (using receiver analyzer). This method uses a receiver analyzer to create the desired waveform at the required bit rate, set a value of  $E_b/N_0$  for that waveform, and create the multiple static 2-ray channel conditions in one unit, as shown in [Figure 10-5](#). The output of the receiver analyzer is the combination of waveform, additive noise, and the multipath channel condition already applied. As with the channel emulator, direct control over the 2-ray channel parameters ( $\Gamma_1$ ,  $\tau_1$ , and  $r$  or  $\gamma_1$ ) is available within the receiver analyzer.

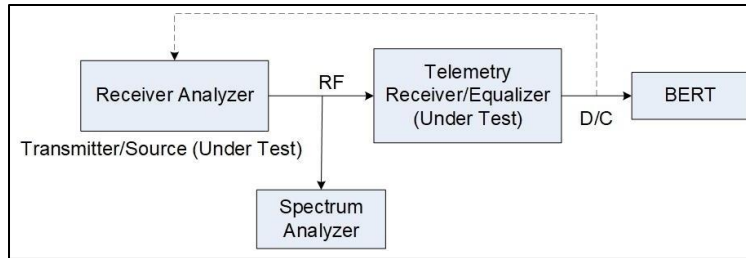

Figure 10-5. Setup using Receiver Analyzer for 2-ray Static Multipath Test

10.2.5 Conditions. This test should be performed using one of the following: A waveform signal source; noise test set to establish signal  $E_b/N_0$  plus a channel emulator to create the 2-ray multipath channel condition; or a receiver analyzer that allows control over the waveform, additive noise, and 2-ray multipath channel condition.

### 10.2.6 Procedure

1. Set the bit error test set or source pattern to generate the desired bit rate with a pseudo-noise bit sequence length of at least  $2^{11}-1$  bits and preferably  $2^{31}-1$  bits long. Set the signal source to generate the required modulation and coding scheme (if required) at the chosen carrier frequency. (If available, amplify the signal with a non-linear amplifier). As a quick check, use a spectrum analyzer to verify the signal spectrum matches the expected modulated waveform at the specified bit rate. If a receiver analyzer is used, then the bit pattern, bit rate, carrier frequency, and modulation and coding scheme are set in this one unit.
2. Using the noise test set (or by other means), set  $E_b/N_0 = 20$  dB for the OTA bit rate. If using the channel emulator, set the output level of the noise test set to match the input level required for the channel emulator. Set  $E_b/N_0 = 20$  dB directly within the receiver analyzer.
3. Set the receiver to match the combination of bit rate, carrier frequency, and modulation/coding scheme chosen for the test. Connect the BERT to the output of the receiver.
4. Connect the modulator/noise test set to the receiver through the channel emulator. If using a receiver analyzer, directly connect it to the receiver/equalizer. To verify end-to-end connection between the modulator and receiver, configure only the LOS direct path. If using a channel emulator, enable the LOS path (Path 1) with unity gain, zero delay, and zero phase shift or enable the pass-through function if available. If using a receiver analyzer, disable the multipath function. Verify that the BERT synchronizes on the correct pseudo-noise bit sequence.
5. If using a channel emulator, enable the specular reflection (Path 2). If using a receiver analyzer, enable the multipath function for a 2-ray multipath condition.
6. There are 165 individual 2-ray channel conditions specified for this test, though not all need to be tested. For each delay  $\tau_1$ , the phase shift  $\gamma_1$  needs to be calculated for each value of  $r$  knowing the OTA bit rate  $R_b$  for the test. The following is one suggested method for running through the test matrix for the multiple 2-ray channel conditions.
  - a. In the noise test set, configure the proper carrier frequency and bit rate or OTA bit rate ( $R_b$ ) if coding is implemented. Set  $E_b/N_0 = 20$  dB. Ensure the noise bandwidth in the noise test set is correctly given the combination of modulation and coding scheme and bit rate. Set the same parameters in the receiver analyzer if appropriate.



- b. Set the LOS path (Path 1) to unity gain ( $\Gamma = 0$  dB), with zero delay ( $\tau = 0$  ns) and zero phase shift ( $\gamma = 0^\circ$ ).
  - c. Select a value of amplitude for the specular reflection (Path 2). The values for  $\Gamma_1$  can be  $-3$  dB,  $-2.5$  dB,  $-1.5$  dB,  $-1$  dB, or  $-0.5$  dB.
  - d. Select a value of delay for the specular reflection (Path 2). The values for  $\tau_1$  can be 50 ns, 100 ns, or 150 ns.
  - e. For the value of delay ( $\tau_1$ ) chosen, calculate the phase shift ( $\gamma_1$ ) using the bit rate ( $R_b$ ) for each value of  $r$ . The values for  $r$  can be 0-1.0 in 0.1 steps (11 values). Record the calculated phase shifts ( $\gamma_1$ ) for each value of  $r$ .
  - f. At each value of  $r$ , allow the BER to stabilize and record this value along with the settings for  $\Gamma_1$ ,  $\tau_1$ , and  $\gamma_1$ . Record the BER value for each combination of telemetry systems being tested.
  - g. After each of the 11 values of  $r$  have been tested, repeat the procedure starting at step c and ending at step f for all remaining values of amplitudes  $\Gamma_1$  and delays  $\tau_1$ .
7. Repeat the procedure, steps a through g for different values of carrier frequency, modulation, and coding, and bit rate ( $R_b$ ) as required.

**10.2.7 Data Reduction.** For each value of amplitude ( $\Gamma_1$ ) and delay shift ( $\tau_1$ ), there are 11 values of calculated phase shift ( $\gamma_1$ ) with resulting BER. One way of displaying this information is to plot BER versus phase shift on a polar plot with BER as the radius and phase shift as the angle for each test condition. Another method is to plot phase shift versus BER on a linear X-Y plot. Alternately, DQM can be used in place of BER if the receiver under test outputs DQM. Each test condition can be plotted via either method and compared.

<b>Data Sheet 10-2. System Bit Error Rate for Static 2-ray Channels</b>																																								
<b>Test 10.2</b>	<b>System Bit Error Rate for Static 2-ray Channels</b>																																							
Manufacturer: _____	Model: _____																																							
Serial No.: _____																																								
Test Personnel: _____	Date: _____																																							
<p style="text-align: center;">Center Frequency (MHz): _____ Bit Rate: _____</p> <p>Modulation Mode: PCMFM    SOQPSK    ARTM CPM</p> <p>Coding: STC   LDPC   STC-LDPC   Coding Rate: 4/5   2/3   1/2   Block Size: 1024   4096</p> <p style="text-align: center;">2-Ray Channel Condition:   Amplitude (<math>\Gamma_1</math>) (dB): _____   Delay (<math>\tau_1</math>) (ns): _____</p>																																								
<table border="1" style="margin: auto; border-collapse: collapse; width: 60%;"> <thead> <tr> <th style="padding: 5px;">Multiple (<math>r</math>)</th> <th style="padding: 5px;">Phase Shift (<math>\gamma_1</math>)</th> <th style="padding: 5px;">BER/DQM</th> </tr> </thead> <tbody> <tr><td style="text-align: center;">0.0</td><td></td><td></td></tr> <tr><td style="text-align: center;">0.1</td><td></td><td></td></tr> <tr><td style="text-align: center;">0.2</td><td></td><td></td></tr> <tr><td style="text-align: center;">0.3</td><td></td><td></td></tr> <tr><td style="text-align: center;">0.4</td><td></td><td></td></tr> <tr><td style="text-align: center;">0.5</td><td></td><td></td></tr> <tr><td style="text-align: center;">0.6</td><td></td><td></td></tr> <tr><td style="text-align: center;">0.7</td><td></td><td></td></tr> <tr><td style="text-align: center;">0.8</td><td></td><td></td></tr> <tr><td style="text-align: center;">0.9</td><td></td><td></td></tr> <tr><td style="text-align: center;">1.0</td><td></td><td></td></tr> <tr><td> </td><td></td><td></td></tr> </tbody> </table>		Multiple ( $r$ )	Phase Shift ( $\gamma_1$ )	BER/DQM	0.0			0.1			0.2			0.3			0.4			0.5			0.6			0.7			0.8			0.9			1.0					
Multiple ( $r$ )	Phase Shift ( $\gamma_1$ )	BER/DQM																																						
0.0																																								
0.1																																								
0.2																																								
0.3																																								
0.4																																								
0.5																																								
0.6																																								
0.7																																								
0.8																																								
0.9																																								
1.0																																								

### 10.3. TEST: Receiver/Equalizer Link Availability for Dynamic Channel 1

10.3.1 Purpose. This test assesses the link improvement measured in terms of link availability over the test period provided by the equalizer when subjected to a dynamic 3-ray multipath channel that emulates an over-the-land transmission channel.

10.3.2 Test Equipment. There are two methods available for generating time-varying dynamic multipath channels. The first method uses a channel emulator; the second method is with a receiver analyzer. Either unit needs the ability to set the Doppler frequency,  $f_d$ , in the specular reflection path (Path 2) and must have the ability to control the amplitude distribution and power spectral density of  $\Gamma_2(t)$ , in other words the spectrum shape of the fading profile in the diffuse reflection path. (As explained in the introductory section, the amplitude distribution can be approximated by a Rayleigh random process with a power spectral density given by Equation 5).

- Channel emulator method: Bit error test set with the ability to capture bit error statistics, modulator (e.g., TM transmitter, I/Q signal source, etc.), noise test set, channel emulator, receiver under test, spectrum analyzer.
- Receiver analyzer method: Receiver analyzer, bit error test set with the ability to capture bit error statistics, receiver under test, spectrum analyzer

10.3.3 Setup (using a channel emulator). This method uses the channel emulator to create the dynamic multipath channel and is placed between the signal source and the receiver, as shown in [Figure 10-6](#). The channel emulator allows direct control over the specular reflection (Path 2) parameters ( $\Gamma_1$ ,  $\tau_1$ ,  $f_d$ ) and diffuse reflection (Path 3) parameters ( $\Gamma_2$ ,  $\tau_2$ ,  $B_{rms}$ , spectrum shape) that together create the dynamic 3-ray test condition. A noise test set is also used to set a fixed value of  $E_b/N_0$  for the test signal prior to being subjected to multipath by the channel emulator. In order to calculate link availability during the test period the BERT must be able to capture instantaneous bit errors, calculate the resulting bit error rate, and log pattern synchronization status over some test interval (preferably over one-second intervals).

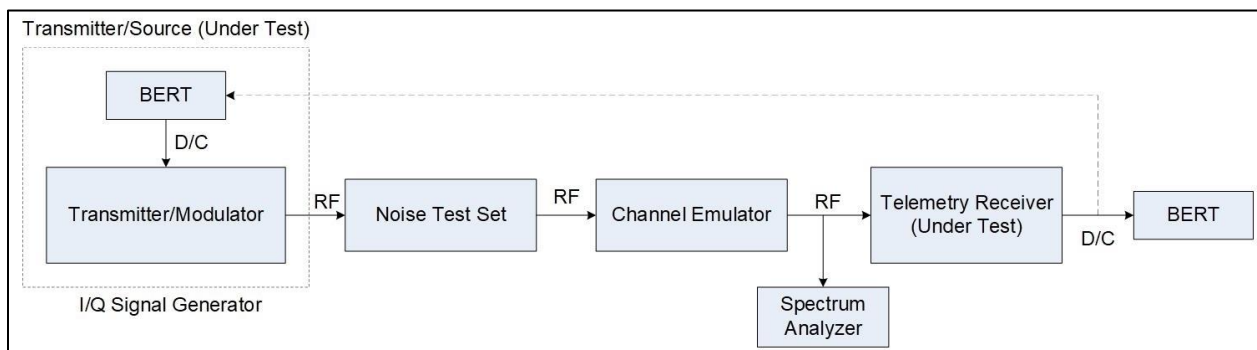

Figure 10-6. Setup using Channel Emulator for Dynamic Channel Multipath Test

10.3.4 Setup (using receiver analyzer). This method uses a receiver analyzer to create the waveform at the required bit rate, set a value of  $E_b/N_0$  for the OTA bit rate for that waveform, and create the dynamic 3-ray multipath channel, as shown in [Figure 10-7](#). In addition to setting the individual path delays and amplitudes, the receiver analyzer must also be able to control  $f_d$ ,  $B_{rms}$ , and the spectrum shape of the fading profile in the diffuse reflection path (Path 3). The output of the receiver analyzer is the waveform with noise added with the dynamic multipath

channel condition already applied. A BERT must also be used that can record bit error statistics. This can be accomplished with an external BERT, the receiver analyzer, or the receiver itself if so equipped.

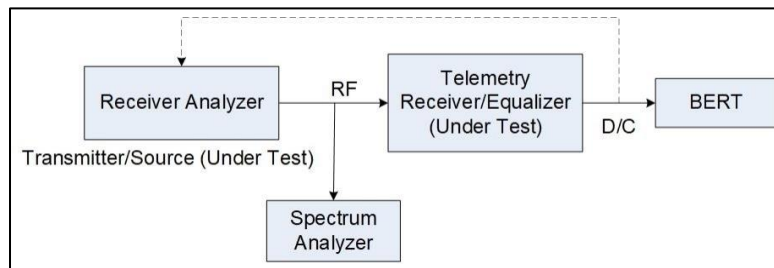

Figure 10-7. Setup using Receiver Analyzer for Dynamic Channel Multipath Test

**10.3.5 Conditions.** This test should be performed using one of the following: A waveform signal source; noise test set to establish signal  $E_b/N_0$  plus a channel emulator to create the dynamic 3-ray multipath channel condition; or a receiver analyzer that allows control over the waveform, bit rate, additive noise, and dynamic 3-ray channel parameters. Either setup requires a BERT with recording capability.

#### 10.3.6 Procedure

1. Set the bit error test set or source pattern to generate the desired bit rate with a pseudo-noise bit sequence length of at least  $2^{11}-1$  bits and preferably  $2^{31}-1$  bits long. Set the signal source to generate the required modulation and coding scheme (if applicable) at the chosen carrier frequency. (If available, amplify the signal with a non-linear amplifier). As a quick check, use a spectrum analyzer to verify the signal spectrum matches the expected modulated waveform at the specified OTA bit rate. If a receiver analyzer is used, then the bit pattern, bit rate, carrier frequency, modulation scheme, and coding are set in this one unit.
2. Using the noise test set (or by other means), set  $E_b/N_0 = 20$  dB for the OTA bit rate. If using the channel emulator, set the output level of the noise test set to match the input level required for the channel emulator. Set  $E_b/N_0 = 20$  dB directly within the receiver analyzer.
3. Set the receiver to match the combination of bit rate, carrier frequency, and modulation and coding scheme chosen for the test. Connect the BERT to the output of the receiver.
4. Connect the modulator/noise test set to the receiver through the channel emulator. If using a receiver analyzer, directly connect it to the receiver. To verify end-to-end connection between the modulator and receiver, configure only the LOS direct path. If using a channel emulator, enable the LOS path (Path 1) with unity gain, zero delay, and zero phase shift or enable the pass-through function if available. If using a receiver analyzer, disable the multipath function. Verify that the BERT synchronizes on the correct pseudo-noise bit sequence.
5. If using a channel emulator, enable the direct (Path 1), specular reflection (Path 2), and diffuse reflection (Path 3) paths for the desired dynamic multipath condition. If using a receiver analyzer, enable the required parameters to create the required dynamic 3-ray multipath condition.
6. In order to create the proper dynamic channel to emulate a real-world channel condition, some emulator parameters will have to be calculated. In addition, the diffuse reflection path

(Path 3) will have to be configured for the proper fading spectrum shape. Once set, the dynamic multipath channel is valid for one combination of vehicle speed and carrier frequency (or telemetry band). The following is one suggested method for creating the proper channel and running a test.

- a. Set the carrier frequency, modulation and coding, and over the bit rate ( $R_b$ ), for an  $E_b/N_0 = 20$  dB. Ensure the noise bandwidth in the noise test set is correct given the combination of modulation and coding scheme and bit rate.
  - b. Set the LOS path (Path 1) channel parameters to unity gain ( $\Gamma_0 = 0$  dB), with zero delay ( $\tau_0 = 0$  ns), zero phase shift ( $\gamma_0 = 0^\circ$ ), and zero rate of Doppler frequency ( $f_d = 0$  Hz). The fading Doppler spread and spectrum shape should not be enabled.
  - c. Set the specular reflection path (Path 2) for  $\Gamma_1 = -0.5$  dB with delay  $\tau_1 = 50$  ns and phase shift  $\gamma_1 = 0^\circ$ .
  - d. Calculate the rate of Doppler frequency  $f_d$ , knowing the vehicle velocity and carrier frequency for the test. Use the proper Doppler frequency factor in [Table 10-1](#) to calculate  $f_d$ . If another velocity is required, scale the Doppler frequency factor appropriately. Set the rate of Doppler frequency in the specular reflection path (Path 2) to the calculated value.
  - e. Set the diffuse reflection path (Path 3) for  $\Gamma_2 = -20$  dB with delay  $\tau_2 = 155$  ns and phase shift  $\gamma_2 = 0^\circ$ .
  - f. Select the proper value of fading Doppler spread  $B_{rms}$  from [Table 10-2](#) knowing the telemetry band and vehicle velocity. Input this value for fading Doppler spread in the diffuse reflection path (Path 3).
  - g. Select the values in the diffuse reflection path (Path 3) that approximate a Rayleigh random process with a suitable power spectral density in Equation 5.
  - h. At this point the emulation is ready to run. The emulation will perform one complete cycle every  $1/f_d$  seconds.
  - i. Enable BERT logging and run the emulation for at least 10 cycles or  $10/f_d$  seconds for each SUT. Using the captured BERT statistics, calculate the link availability for each test using the duration of  $10/f_d$  seconds for the calculation. Tabulate the results for each SUT using Data Sheet 10-4.
7. Repeat the procedure, steps a through i for different values of modulation and coding scheme and bit rate ( $R_b$ ) as required. If new values of carrier frequency and/or vehicle velocity change, new channel parameters  $f_d$  and  $B_{rms}$  will have to be determined and used for the test.

**10.3.7 Data Reduction.** The output of the test is link availability over 10 cycles, or  $10/f_d$  seconds of the dynamic channel emulation. Using the BERT statistics captured during each test, link availability<sup>13</sup> can be calculated. In the context of this test, link availability can be expressed as Equation 10-6. A severely errored second (SES) is typically defined as a one-second interval where  $BER \geq 1 \times 10^{-5}$ . Lost time (LT, expressed in seconds) is tallied when the BERT loses pattern synchronization.

---

<sup>13</sup> Robert Jefferis. "Link Availability and Error Clusters in Aeronautical Telemetry." In *Proceedings of the International Telemetry Conference*, Las Vegas, NV, 25-28 October 1999.

$$\text{Link Availability (\%)} = \left[ \frac{\left(\frac{10}{f_d}\right) - (\Sigma SES + LT)}{\left(\frac{10}{f_d}\right)} \right] (100\%) \quad (\text{Eq. 10-6})$$

Once carrier frequency (telemetry band) and velocity are selected that determine  $f_d$  and  $B_{rms}$ , the dynamic 3-ray channel emulation is valid for any combination of modulation and coding scheme and bit rate. The system configuration with the greatest resulting link availability is the system with the greatest multipath immunity. The system with the lowest link availability is the system with the greatest multipath susceptibility.

<b>Data Sheet 10-3. System Link Availability for Dynamic Channel 1</b>				
<b>Test 10.3</b>	<b>System Link Availability for Dynamic Channel 1</b>			
Manufacturer: _____	Model: _____			
Serial No.: _____				
Test Personnel: _____	Date: _____			
Center Frequency (MHz): _____ Bit Rate: _____				
Modulation Mode: PCMFM SOQPSK ARTM CPM				
Coding: STC LDPC STC-LDPC Coding Rate: 4/5 2/3 1/2 Block Size: 1024 4096				
3-Ray Dynamic Channel Condition Settings: $f_d$ (Hz): _____ $B_{rms}$ (Hz): _____				
Test Time ( $10/f_d$ ) (sec/cycle): _____ Velocity (knots): _____				
<table border="1" style="margin: auto; border-collapse: collapse;"> <tr> <td style="padding: 5px;">Link Availability (%)</td> </tr> <tr> <td style="height: 20px;"> </td> </tr> <tr> <td style="height: 20px;"> </td> </tr> </table>		Link Availability (%)		
Link Availability (%)				

## 10.4. TEST: System Link Availability for Dynamic Channel 2

10.4.1 Purpose. This test assesses the system multipath immunity when measured in terms of link availability over the test period when subjected to a dynamic 3-ray multipath channel that emulates an over-the-water transmission channel.

10.4.2 Test Equipment. Same as Test 10.3.

10.4.3 Setup. Same as Test 10.3.

10.4.4 Conditions. Same as Test 10.3.

10.4.5 Procedure. If testing with the calm sea channel approximation, use the procedure in Test 10.3 with the following changes in step 6.

- c. Set the specular reflection path (Path 2) for  $\Gamma_1 = -1.7$  dB with delay  $\tau_1 = 35$  ns and phase shift  $\gamma_1 = 0^\circ$ .
- e. Set the diffuse reflection path (Path 3) for  $\Gamma_2 = -12.2$  dB with delay  $\tau_2 = 69$  ns and phase shift  $\gamma_2 = 0^\circ$ .

If testing with the rough sea channel approximation, use the procedure in Test 10.3 with the following changes in step 6.

- c. Set the specular reflection path (Path 2) for  $\Gamma_1 = -2.8$  dB with delay  $\tau_1 = 25$  ns and phase shift  $\gamma_1 = 0^\circ$ .
- e. Set the diffuse reflection path (Path 3) for  $\Gamma_2 = -10.5$  dB with delay  $\tau_2 = 54$  ns and phase shift  $\gamma_2 = 0^\circ$ .

10.4.6 Data Reduction. Same as Test 10.3.



<b>Data Sheet 10-4. System Link Availability for Dynamic Channel 2</b>				
<b>Test 10.3</b>	<b>System Link Availability for Dynamic Channel 2</b>			
Manufacturer: _____	Model: _____			
Serial No.: _____				
Test Personnel: _____	Date: _____			
Center Frequency (MHz): _____ Bit Rate: _____				
Modulation Mode: PCMFM SOQPSK ARTM CPM				
Coding: STC LDPC STC-LDPC Coding Rate: 4/5 2/3 1/2 Block Size: 1024 4096				
3-Ray Dynamic Channel Condition Settings: $f_d$ (Hz): _____ $B_{rms}$ (Hz): _____				
Test Time ( $10/f_d$ ) (sec/cycle): _____ Velocity (knots): _____				
<table border="1" style="margin: auto; border-collapse: collapse;"> <thead> <tr> <th style="padding: 5px;">Link Availability (%)</th> </tr> </thead> <tbody> <tr> <td style="height: 20px;"> </td> </tr> <tr> <td style="height: 20px;"> </td> </tr> </tbody> </table>		Link Availability (%)		
Link Availability (%)				

This page intentionally left blank.

## CHAPTER 11

### Test Procedures for Assessing Telemetry Receiver Data Quality Metrics

#### 11. General

The DQM is defined in 106-22 Appendix 2G<sup>14</sup> and has been implemented in TM receivers. The following test methods can be used to test the DQM values from receivers in order to assess how well the receiver estimates the resulting BEP versus actual BER over a given transmission channel condition. This comparison is relative. Other test methods are available to determine actual receiver performance in degraded transmission channel conditions.

The following equations define the relationship between the resulting DQM and the estimated BEP of the received and demodulated/decoded data. The general case of DQM is calculated as shown in Equation 11-1.

$$DQM = \frac{-\log_{10}(LR)}{k} * 2^n \quad (\text{Eq. 11-1})$$

where:  $k$  is the exponent for lowest estimated BEP  
 $n$  is number of bits in the DQM field  
 $LR$  is the likelihood ratio, as calculated in Equation 11-2.

$$LR = \frac{BEP}{(1 - BEP)} \quad (\text{Eq. 11-2})$$

For most cases,  $k=12$  and  $n=16$ . [Table 11-1](#) defines LR and DQM for various values of BEP given these values of  $k$  and  $n$ .

BEP	LR	DQM
0.5	1.00	0
1e-01	1.11111e-01	5211
1e-02	1.01010e-02	10898
1e-03	1.00100e-03	16381
1e-04	1.00010e-04	21845
1e-05	1.00001e-05	27306
1e-06	1.00000e-06	32767
1e-07	1.00000e-07	38229
1e-08	1.00000e-08	43690
1e-09	1.00000e-09	49151
1e-10	1.00000e-10	54613
1e-11	1.00000e-11	60074
1e-12	1.00000e-12	65535

<sup>14</sup> Range Commanders Council. "Standards for Data Quality Metrics and Data Quality Encapsulation." Appendix 2G in *Telemetry Standards*. RCC 106-22. May 2022. Retrieved 6 October 2022. Available at <https://www.trmc.osd.mil/wiki/x/EoPOBg>.

Data quality encapsulation (DQE) defines the frame structure for the transmission of the data payload with the DQM value associated with that payload, and only that payload. Throughout this test method, this structure is assumed and implicitly tested.

16 Bits	12 Bits	4 Bits	16 Bits	1024 – 16384 Bits
SW	RSV	VER	DQM	PAYLOAD

- SW = Sync Word. The sync word is a fixed value of 0xFAC4.
- RSV = Reserved. Reserved for future use.
- VER = RCC 106 Version number.
- DQM = Data Quality Metric.
- PAYLOAD = Telemetry data payload to which the DQM value applies.

[Table 11-2](#) lists the types of tests in this test method with the section number for each test.

<b>Table 11-2. Test Matrix for Data Quality Metric Testing</b>	
<b>Test Number</b>	<b>Test Description</b>
<a href="#">11.1</a>	BER vs BEP with Additive Noise
<a href="#">11.2</a>	DQM (BEP) Step and Dwell Response
<a href="#">11.3</a>	BER vs BEP with Adjacent Channel Interference
<a href="#">11.4</a>	BER vs BEP for Static 3-Ray Multipath Channel Conditions
<a href="#">11.5</a>	BER vs BEP for Static 2-Ray Multipath Channel Conditions
<a href="#">11.6</a>	DQM (BEP) Resynchronization Response

### **Capturing and Comparing BEP with BER**

This test method assumes that the unit under test can estimate the BEP for the payload in the DQE frame structure. Stated another way, the number of actual bit errors in a DQE frame should match the number predicted by the BEP (derived from DQM) for that frame. This assumption should hold true for each and every DQE frame.

For the BERs used in the following tests, the estimated BEP can and will result in a bit error value much, much less than 1 for a single DQE frame. For some test cases it is highly likely the estimated BEP for the payload in that DQE frame will result in a number of bit errors that is not an integer value but rather a fraction of a bit much less than 1. Realizing this, it becomes evident that multiple payloads must be captured and averaged. The lower the estimated BEP, the larger amount of DQE frames (payloads) need to be captured and averaged in order to perform a valid BEP to BER comparison.

The optimal method of making this BEP comparison with BER would be to measure BER for each and every possible value of BEP. Per [Table 11-1](#) when  $k=12$  and  $n=16$ , there are 65,536 individual DQM values resulting in the same number of BEP estimates. This comparison would be made by creating 65,356 “bins” and adding to these bins when a DQM value is captured matching that bin value. Over time these bin values would be averaged to arrive at a BEP that could be compared to the actual BER. This optimal comparison method is impractical

as it requires the tests to be run over a very long time in order to achieve a large number of samples aimed at obtaining valid average results.

A natural extension of this approach would be to group individual bins into one larger range of bin values containing  $M$  individual bins. This grouping effectively acts as a multiplier to the number of DQM values recorded, resulting in reduced test time. The question then becomes how many of the 65,356 possible bins should be combined to provide one singular BEP estimate. Granularity of the bin sizes then becomes the trade-off. If  $M$  is made too large, accuracy is diminished. If  $M$  is too small, longer test times are required to achieve a valid average BEP. Ultimately, BER and BEP should be averaged in segregated bins with length  $N$  corresponding to the DQM values chosen. For example, if  $M=64$ , the size or length of each bin spans  $N=1024$  DQM values. In terms of BEP, if a BEP of  $1.000e-06$  is chosen as a reference bin value, then the bin would span  $1.000e-06$  to  $1.540e-6$ .

One possible process for correlating DQM and BER values is to divide the set of all possible DQM values into  $M$  bins as discussed above. For each bin, associate two accumulators: one is a count of total bits; and one is a count of errored bits. At the start of a test, reset all accumulators to zero. Then, for each DQE frame, determine which bin contains the DQM value for that frame; call it bin  $d$ . Add the number of bits in the frame (i.e., payload length) to total bit count accumulator  $t$ . Likewise, add the number of bit errors in the frame to errored bit count accumulator  $e$ . Once a test is complete, perform a linear average of all bin values to arrive at the BEP corresponding to each bin. In this example bin  $d$  can be compared to the average BER for bits recorded in each bin calculated by  $e/t$ . For a more thorough explanation of this approach see Temple.<sup>15</sup>

## 11.1. TEST: BER versus Estimated BEP (DQM) with Additive Noise

11.1.1 Purpose. This test method provides a means to assess the ability of the receiver to provide an accurate assessment of signal quality in the presence of AWGN. The basis of comparison is the relative performance of BER versus estimated BEP (DQM) when the receiver is subjected to a signal corrupted with calibrated AWGN. The amount of AWGN added to the signal of interest is set in terms of  $E_b/N_0$ .

11.1.2 Test Equipment. Various methods are available for performing this test, which include using a simple step attenuator/power meter to determine and set  $E_b/N_0$ , a noise test set that allows direct control of  $E_b/N_0$ , or a receiver analyzer.

- Step attenuator/power meter method: Bit error test set, modulator (e.g. TM transmitter, I/Q signal source, etc.), power meter, step attenuator (in 1 dB steps, 0.1 dB steps for coded waveforms), DQM message reader, spectrum analyzer, receiver metric reader (optional)
- Noise test set method: Bit error test set, modulator (e.g. TM transmitter, I/Q signal source, etc. with required encoding as necessary), noise test set, DQM message reader, spectrum analyzer, internal receiver metric reader (optional)

---

<sup>15</sup> Kip Temple. "Some Thoughts on Testing the Data Quality Metric". In *International Telemetry Conference Proceedings*, October 2022.

- Receiver analyzer method: Receiver analyzer with DQM read capability, bit error test set (if required), spectrum analyzer, receiver metric reader (optional)

11.1.3 **Setup (step attenuator/power meter method).** This method is for manually setting  $E_b/N_0$  by using the combination of input signal level and internal receiver noise to calibrate the carrier-to-noise level. When the step attenuator/power meter method is used, the input attenuation value is determined, which results in an  $E_b/N_0$  of 10 dB. This setup is shown in [Figure 11-1](#). If 10 dB does not provide enough dynamic range to fully characterize the detection performance of the modulation/coding under test, use 15 dB instead. Care should be taken when making these measurements with the results being stable and repeatable to no more than 0.5 dB. (Note: If forward error correction is added to the test waveform, extra care should be taken when making the following measurements as the slope of the LDPC detection curve is extremely steep exhibiting large changes in BER corresponding to small changes in  $E_b/N_0$ .)

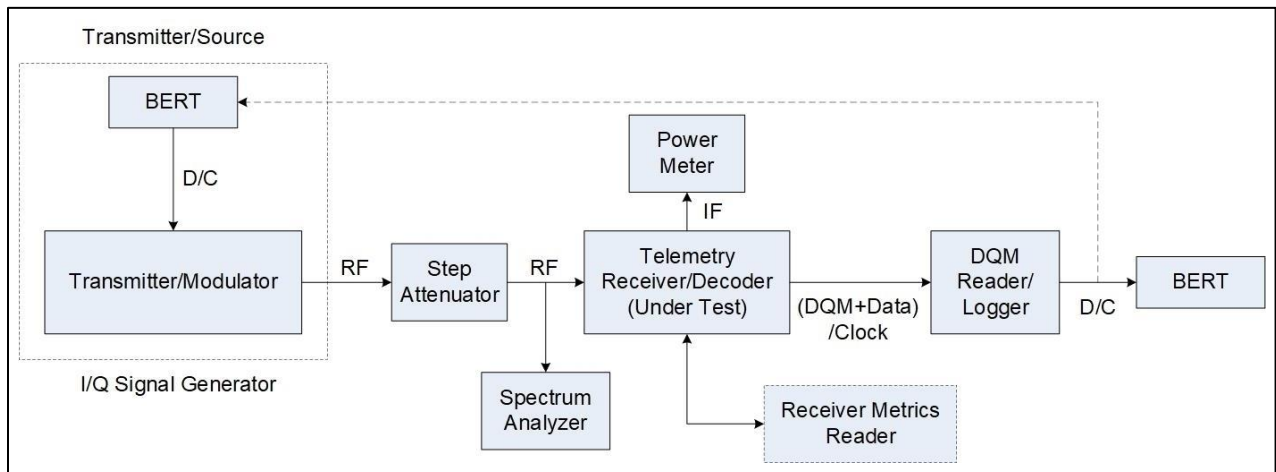

Figure 11-1. Setup for Step Attenuator/Power Meter for BER versus BEP Test

- Place the signal source in carrier-only mode. There are several ways of doing this depending upon the specific modulator and modulation scheme being used. (For example, when implementing SOQPSK-TG, apply a “101010” repeating pattern to the modulator. This pattern should produce an unmodulated carrier signal at the selected carrier frequency.) Turn off the source and set the attenuation to the maximum value. Use AGC freeze or manual gain to set the noise power at the receiver IF output in the linear region. Measure and note the IF power level in watts.
- Turn on the source and decrease the attenuation until the power level at the IF output increases by 3 dB (double the power) over the value recorded in step 1. Note this attenuation setting as it will be the baseline for the 0 dB IF carrier-to-noise ratio ( $C/N=0$  dB) with an equivalent  $E_b/N_0$  of:

$$\frac{E_b}{N_0} (dB) = 10 \log \left( \frac{IF BW}{Bit Rate} \right) \quad (Eq. 11-3)$$

- Put the receiver in AGC mode and decrease the attenuation by approximately:

$$10dB - 10\log\left(\frac{IF\ BW}{Bit\ Rate}\right) \quad (\text{Eq. 11-4})$$

4. Use AGC freeze or manual gain to set the noise power at the receiver IF output in the linear region. Measure and note the IF power level in watts. This will be the carrier plus noise (C+N) value. (Note: The bit rate used in the equations is the uncoded bit rate. Units or order of magnitude of IF BW and bit rate should be the same [e.g., MHz and Mbps].)
5. Turn off the source and set the attenuation to the maximum value. Measure the noise power level (N) in watts. Calculate the  $E_b/N_0$ :

$$\frac{E_b}{N_0} (dB) = 10\log\left(\frac{(C + N) - N}{N}\right) + 10\log\left(\frac{IF\ BW}{Bit\ Rate}\right) \quad (\text{Eq. 11-5})$$

The most-accurate value to use for IF bandwidth is the equivalent noise power bandwidth. If the -3 dB bandwidth (either measured or specified) is the only value readily available, it will give nearly the same value for  $E_b/N_0$ . If the measured value is not within 0.1 dB of 10 dB, change the attenuation by the appropriate amount to get within 0.1 dB of 10 dB and repeat the (C+N) and (N) measurements and calculations. At the conclusion,  $E_b/N_0$  is now calibrated and will change by 1 dB for each 1 dB change in attenuation value.

11.1.4 **Setup (for noise test set method).** This method is for utilizing a noise test set for directly setting  $E_b/N_0$  as shown in [Figure 11-2](#). Once the bit rate and noise bandwidth are set in the noise test set, the signal from the transmitting source is applied and the noise test set will measure carrier power, allowing direct control over  $E_b/N_0$  by varying the amount of calibrated noise N.

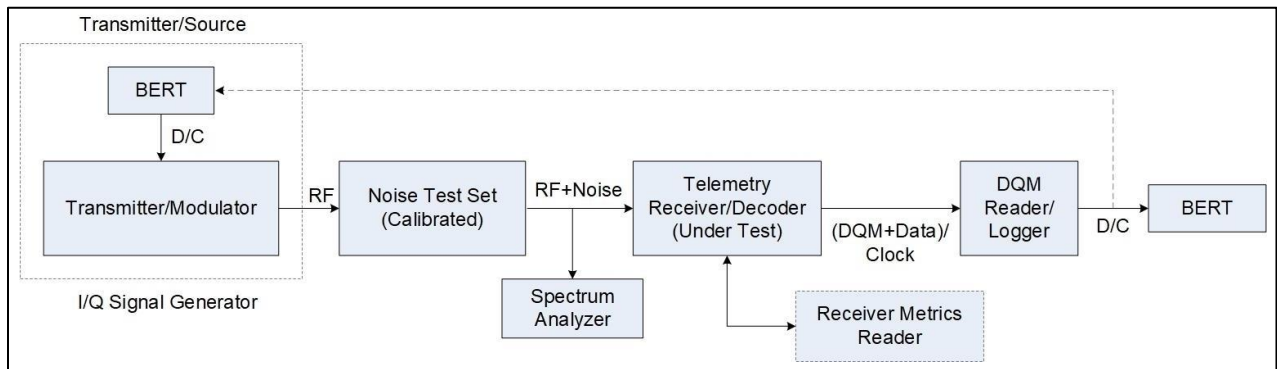



Figure 11-2. Setup using Noise Test Set for BER versus BEP Test

<p><b>NOTE</b></p> 	<p>The bit rate set in the noise test set is the uncoded bit rate. The noise test set uses the following equation to set <math>E_b/N_0</math> directly:</p> $\frac{E_b}{N_0} (dB) = 10\log\left(\frac{C}{N}\right) + 10\log\left(\frac{IF\ BW}{Bit\ Rate}\right)$
--	---

11.1.5 **Setup (for receiver analyzer method).** This method utilizes a receiver analyzer for generating the TM waveform and directly setting  $E_b/N_0$  as shown in [Figure 11-3](#). Most receiver analyzers will require configuration of the signal source (bit pattern and rate, modulation,

coding) and of the test to be performed (in this case  $E_b/N_0$  vs. BER). After these steps, setting  $E_b/N_0$  directly will be possible and the signal from the receiver analyzer will have the exact amount of AWGN already applied.

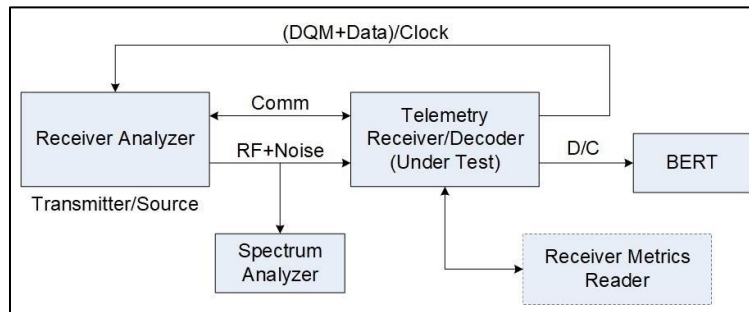

Figure 11-3. Setup using Receiver Analyzer for BER versus BEP Test

11.1.6 Conditions. This test can be performed using any of the three setups that set  $E_b/N_0$  and capture the resulting DQM value:

- A waveform signal source followed by an attenuator and a TM receiver/decoder that are then calibrated in terms of  $E_b/N_0$ ;
- A waveform signal source plus a noise test set that generates the signal at the selected  $E_b/N_0$  directly;
- An integrated waveform signal source/calibrated additive noise source (e.g., receiver analyzer) that generates the signal at the desired  $E_b/N_0$  directly.

If a TM transmitter is not used as the signal source, the signal should be non-linearly amplified to better reflect receiver/demodulator detection performance in a typical TM link.

#### 11.1.7 Procedure

1. Set the bit error test set or source pattern to generate the desired bit rate with a pseudo-noise sequence length of at least  $2^{11}-1$  bits and preferably at least  $2^{23}-1$  bits long (the longer sequence is a better simulation of the characteristics of an encrypted signal). Set the signal source to generate the required modulation scheme and coding scheme (if applicable). (If available, amplify the signal with a non-linear amplifier if a TM transmitter or receiver analyzer are not used as signal sources). As a quick check, use a spectrum analyzer to verify the signal spectrum looks like the expected modulated and coded (if applicable) waveform.
2. Set the receiver/decoder to match the combination of center frequency and modulation scheme/coding scheme chosen for the modulator. Set the initial  $E_b/N_0$  to approximately 20 dB; verify this setting using the spectrum analyzer. Verify that the bit error test set synchronizes in the non-inverted state. If the bit error test set does not synchronize, invert the output data polarity of the receiver/decoder. If the bit error test set now synchronizes, there is a polarity inversion somewhere in the generation-detection chain.
3. Detection efficiency and range of  $E_b/N_0$  depends upon the modulation and/or coding scheme selected. The range of values for  $E_b/N_0$  should be adjusted accordingly. Measure the detection performance in terms of  $E_b/N_0$  versus BER for error rates spanning  $1 \times 10^{-7}$  to  $1 \times 10^{-2}$ . For uncoded waveforms a 1 dB step in  $E_b/N_0$  is sufficient. For waveforms coupled



with forward error correction, 0.1 dB steps in  $E_b/N_0$  will be required. Record the BER for each value of  $E_b/N_0$  on Data Sheet 11-1. Allow BER to stabilize prior to annotating on the data sheet.

4. On the TM receiver, enable DQM/DQE so the output serial bit stream now incorporates the DQM message in the DQE format. Select the DQE information block size as required. (Note: Default block size without implementing coding is 4096 bits).
5. If the test set up allows, steps 3 and 4 should be combined and DQM and BER values should be captured coincidentally.
6. Repeat step 3, recording only the raw DQM values rather than the exact values of  $E_b/N_0$ . Allow enough time during each  $E_b/N_0$  step so a valid average of DQM and BER can be determined. Annotate the final values on the data sheet.
7. Repeat for other modulation schemes, coding schemes, code rates, and baseband data rates as desired.

11.1.8 Data Reduction. Using the above equations, convert the DQM values to BEP in Data Sheet 11-1. Compare the measured BER value versus the BEP. This can be illustrated by plotting the resulting BER and BEP versus  $E_b/N_0$  on a linear-logarithmic X-Y scale and/or comparing the measured BER with BEP by plotting the BER and BEP on a logarithmic-logarithmic X-Y scale.



## 11.2. TEST: Estimated BEP (DQM) Step and Dwell Response

11.2.1 Purpose. This test method provides a means to assess the ability of the receiver to provide a fast and accurate assessment of signal quality when there is an abrupt change in signal quality. This test is intended to verify the DQM estimate applies to the DQE payload that directly follows the estimate. The test can use the results from Test Method 11.1 in order to determine applicable values of  $E_b/N_0$  to use for the waveform or waveform/coding combination being tested.

11.2.2 Test Equipment. The test equipment used in this test are similar to Test Method 11.1 in that  $E_b/N_0$  needs to be accurately set for the waveform being tested. In addition, the amount of time the signal steps between certain values of  $E_b/N_0$  needs to be controllable and selectable. The resulting BER and DQM values at each step are then captured and recorded.

- Step attenuator/power meter method: Bit error test set, modulator (e.g. TM transmitter, I/Q signal source, with required coding as necessary), power meter, electronically controlled step attenuator (in 0.1 dB steps for LDPC coded signals), function generator (for step and dwell timing), spectrum analyzer, DQM message reader, receiver metric reader (optional)
- Noise test set method: Bit error test set, modulator (e.g. TM transmitter, I/Q signal source, etc. with required coding as necessary), noise test set (with option for external control of  $E_b/N_0$  setting), DQM message reader, spectrum analyzer, receiver metric reader (optional)
- Receiver analyzer method: Receiver analyzer with DQM read capability and ability to vary the time between  $E_b/N_0$  settings, bit error test set (if required), spectrum analyzer, receiver metric reader (optional)

11.2.3 Setup (step attenuator/power meter method). This method is for manually setting  $E_b/N_0$  by using the combination of input signal level and internal receiver noise to calibrate the carrier-to-noise level. Refer to Subsection 11.1.3 steps 1-5 for details on determining the step attenuator value for setting  $E_b/N_0 = 10$  dB. The time source identified in Figure 11-4 sets the rate in which  $E_b/N_0$  values are changed and the amount of time the signal stays at that  $E_b/N_0$  value.

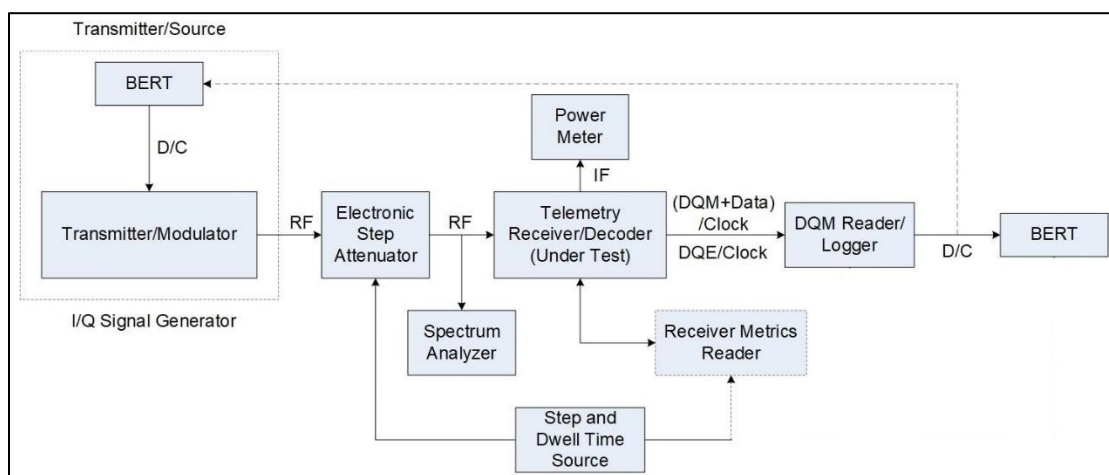

Figure 11-4. Setup for Step and Dwell Testing using Step Attenuator/Power Meter

11.2.4 Setup (for noise test set method). This method is for utilizing a noise test set for directly setting and controlling  $E_b/N_0$ . A time source is used to control when  $E_b/N_0$  in the test set is changed and provides a time mark for this change to receiver metric reader (if used) as shown in [Figure 11-5](#). Once the bit rate and noise bandwidth are set in the noise test set, the signal from the transmitting source is applied and the noise test set will measure carrier power, allowing direct control over  $E_b/N_0$  by varying the amount of calibrated noise  $N$ . The time source identified in [Figure 11-5](#) sets the rate in which  $E_b/N_0$  values are changed and concurrently the amount of time the signal stays at that  $E_b/N_0$  value.

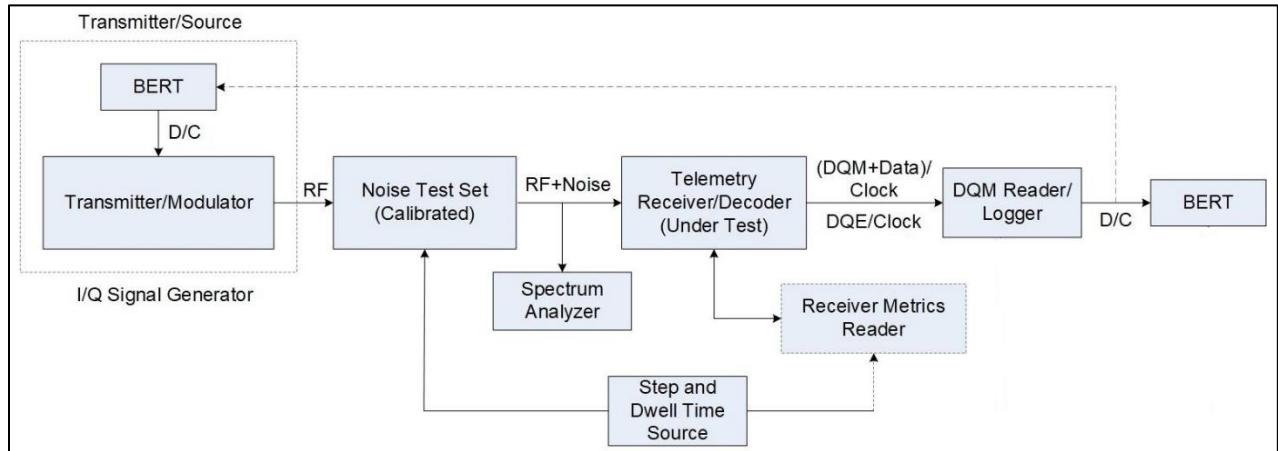

Figure 11-5. Setup for Step and Dwell Test using Noise Test Set

11.2.5 Setup (for receiver analyzer method). This method utilizes a receiver analyzer for generating the TM waveform, setting  $E_b/N_0$  directly, controlling the step and dwell time for each value of  $E_b/N_0$ , and logging the resulting DQM values as shown in [Figure 11-6](#). Receiver analyzers that have this capability will require configuration of the signal source (bit pattern and rate, modulation, coding) and of the test to be performed (in this case  $E_b/N_0$  vs. BER/BEP with stepped  $E_b/N_0$  values). After these steps, the waveform under test will be output from the receiver analyzer with a calibrated value of  $E_b/N_0$  that is stepped at a set rate. A receiver analyzer with this test capability will also have the capability to input the DQE message, make the DQM and BER measurement at the same time instance, log the DQM and BER values, and provide BER statistics.

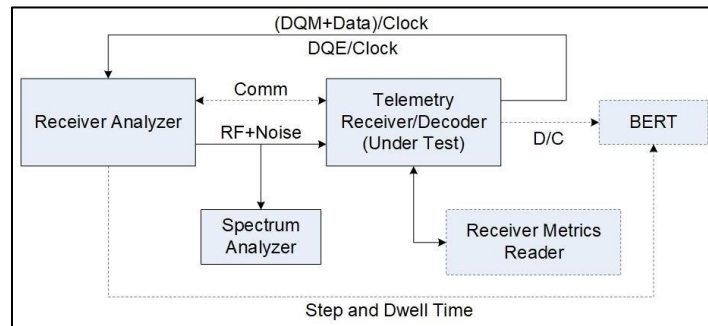

Figure 11-6. Setup for Step and Dwell Test using Receiver Analyzer

11.2.6 Conditions. This test can be performed using any of the three setups that perform the following:

- A waveform signal source followed by manually determining and setting  $E_b/N_0$ , ability to use a timing source to step through values of  $E_b/N_0$ , capture and record the resulting BER and DQM values;
- A waveform signal source followed by a noise test set that generates the signal at the selected  $E_b/N_0$  directly, ability to use a timing source to step through values of  $E_b/N_0$ , capture and record the resulting BER and DQM values;
- An integrated waveform signal source/calibrated additive noise source (e.g. receiver analyzer), allows for selecting  $E_b/N_0$  values at a set step and dwell time, capture and record the resulting BER and DQM values.

If a TM transmitter (or a suitable substitute) is not used as the signal source, the signal should be non-linearly amplified to better reflect detection performance in a typical TM link.

11.2.7 Procedure

1. Set the bit error test set or source pattern to generate the desired bit rate with a pseudo-noise sequence length of at least  $2^{11}-1$  bits and preferably at least  $2^{23}-1$  bits long (the longer sequence is a better simulation of the characteristics of an encrypted signal). Set the signal source to generate the required modulation scheme and coding scheme (if applicable). (If available, amplify the signal with a non-linear amplifier if a TM transmitter or receiver analyzer are not used as signal sources). As a quick check, use a spectrum analyzer to verify the signal spectrum looks like the expected modulated waveform (with coding if applicable).
2. Set the receiver/decoder to match the combination of center frequency and modulation scheme/coding scheme chosen for the modulator. Verify the DQE payload length is consistent between receiver/decoder and DQM reader. Set the initial  $E_b/N_0$  to approximately 20 dB; verify this setting using the spectrum analyzer. Verify that the bit error test set synchronizes in the non-inverted state. If the bit error test set does not synchronize, invert the output data polarity of the receiver/decoder. If the bit error test set now synchronizes, there is a polarity or spectral inversion somewhere in the generation-detection chain.
3. The expected detection efficiency and range of  $E_b/N_0$  depends upon the modulation scheme and whether or not coding is added. If available, use the results from Test Method 11.1 to determine applicable steps of  $E_b/N_0$  values. Choose three to four  $E_b/N_0$  step values. For example,  $E_b/N_0$  step values could be chosen that result in BERs of  $1 \times 10^{-5}$ ,  $1 \times 10^{-4}$ , and  $1 \times 10^{-3}$ .
4. On the TM receiver, enable DQM/DQE so the output serial bit stream now incorporates the DQM message in the DQE frame format. Select the required DQE information block size to match on both the receiver/decoder and DQM reader.
5. Set the timing source to continuously step through the chosen values of  $E_b/N_0$ . For example, if SOQPSK-TG is the modulation scheme being tested,  $E_b/N_0$  values could be 12 dB, 10 dB, and 8 dB resulting in a step sequence of 12, 10, 8, 10, 12, 10, 8, 10, 12,...etc. The actual sequence pattern is not important; only that the pattern is known. Set the rate in which the values of  $E_b/N_0$  are changed from one value to the next. A good starting value for this step

frequency is 1 DQE frame per second or a 1 Hz rate. Typical switching rates can vary between 1 to 100 DQE frames per  $E_b/N_0$  value.

6. Verify that each DQM value in the DQE output from the receiver and corresponding BER values are being captured, decoded, and recorded. The DQM and BER values should be captured at the same time instance corresponding to the step in  $E_b/N_0$  value. Ensure the log file includes the  $E_b/N_0$  value at each step identified in step 4. The resulting data from the test should have  $E_b/N_0$  correlated with captured DQM and BER values.
7. Calculate the dwell time per  $E_b/N_0$  value in bits. This is accomplished by dividing the baseband data rate (without coding) in bits per second by the  $E_b/N_0$  step frequency in Hz. This number provides the time base for plotting and evaluating step test performance.
8. Document the test set up on Data Sheet 11-2.
9. Repeat steps 5 through 8, adjusting the step and dwell time and  $E_b/N_0$  values as required.
10. Repeat for other modulation schemes, coding schemes, code rates, and baseband data rates as desired.

11.2.8 Data Reduction. There are three results from this testing. The first result is how DQM reacts to a step in  $E_b/N_0$ , or alternately how quickly after a step change in  $E_b/N_0$  did the receiver/decoder take to settle on a DQM (BEP) value. The second result is whether the DQM estimate corresponds to the payload in the DQE frame. The third result is the accuracy of the BEP estimate for a dynamic channel condition. In the logged files, convert the captured DQM values to estimated BEP using the above equations. To illustrate the DQM step response, plot the BEP estimates with BER values for each  $E_b/N_0$  setting using a linear-logarithmic X-Y scale with a running total of test time, total payloads captured, or total number of bits captured during the test on the X-axis. To illustrate the DQM accuracy/applicability to the DQE frame, plot and compare the BEP with the measured BER by plotting the data on a logarithmic-logarithmic X-Y scale.

<b>Data Sheet 11-2. Estimated BEP (DQM) Step and Dwell Response</b>	
<b>Test 11.2</b>	<b>Estimated BEP (DQM) Step and Dwell Response</b>
Manufacturer:	Model:
Serial No.:	
Test Personnel:	Date:
Center Frequency: _____ MHz      Modulation/Coding Mode: _____ Uncoded Bit Rate: _____ Mbps      DQE Payload: _____ bits Coding Rate: 1/2 2/3 4/5    Code Block: 1024 4096    Stepped $E_b/N_0$ Values: _____ dB Step Frequency: _____ Hz      Number of bits/step: _____	

### 11.3. TEST: BER versus Estimated BEP (DQM) with Adjacent Channel Interference

11.3.1 Purpose. This test method provides a means to assess the ability of the receiver to provide an accurate assessment of signal quality in the presence of adjacent channel interferers at set C/I ratios. The basis of comparison is BER versus estimated BEP (DQM) when the receiver is subjected to a carrier signal corrupted by adjacent interferer(s). The interferers can be RCC 106-compliant waveforms, cellular-based waveforms, or other waveforms that are indicative of interferers present at or near test ranges. The result will be a function of how well the receiver estimates the interference that is influenced by the modulation method, receiver filter characteristics, bit rates, relative power levels, frequency spacing, and receiver/decoder characteristics. Note, throughout this test method, the terms “carrier” and “victim” will be used interchangeably.

11.3.2 Test Equipment. The test equipment used in this test, regardless of equipment configuration, are all required to perform the same function: add calibrated noise to the carrier, add adjacent channel interferers at a set C/I (victim) ratio, then capture and record the resulting BER and DQM values for each ACI condition.

- Discrete component method: Bit error test sets, interference and carrier signal sources with encoding as required (e.g., TM transmitter, I/Q signal source), attenuators, wideband noise source, power dividers, DQM message reader, spectrum analyzer, internal receiver metric reader (optional)
- Noise and interference test set method: Bit error test sets, interference and carrier signal sources with encoding as required (e.g. TM transmitter, I/Q signal source), noise and interference test set, DQM message reader, spectrum analyzer (optional), internal receiver metric reader (optional)
- Receiver analyzer method: Receiver analyzer with DQM read capability and capability to generate the required TM signals at a set C/I value, spectrum analyzer, bit error test set (if required), receiver metric reader (optional)

11.3.3 Setup (using discrete component method). This method is for manually setting adjacent channel interferers at a set C/I value using a combination of attenuators and power dividers (combiners). A noise source is used to add noise to the victim signal, resulting in a known BER of the victim signal. A DQM reader/logger and BERT are used to collect the resulting DQM and BER values of the victim signal throughout the testing. This set up is illustrated in [Figure 11-7](#).



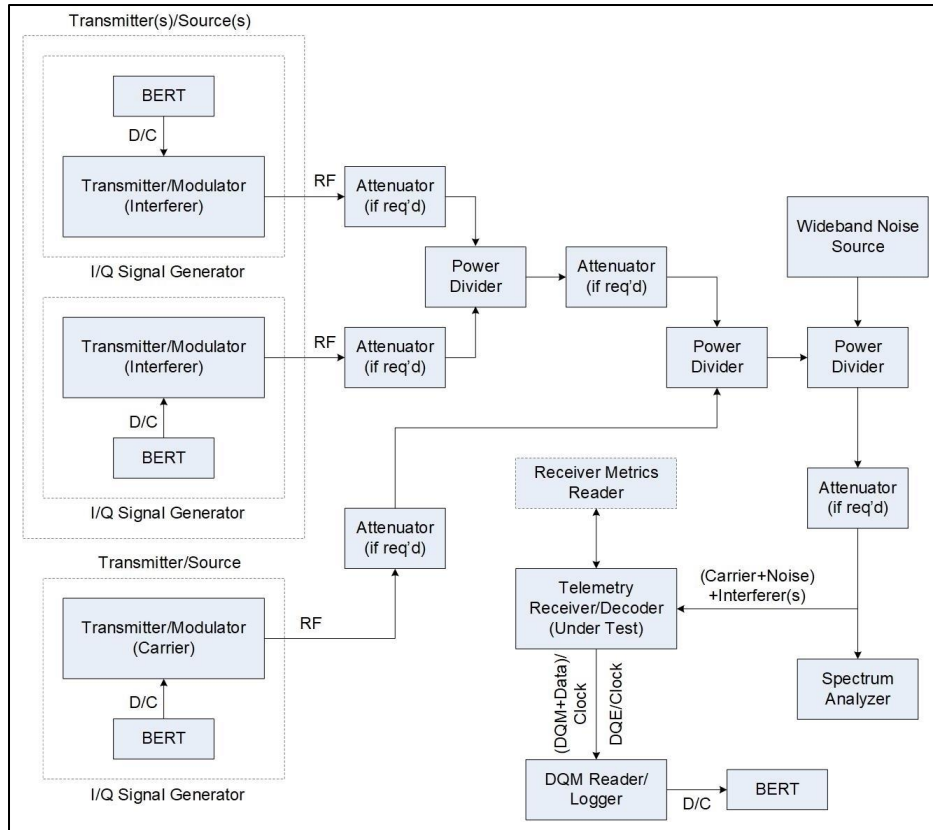

Figure 11-7. Setup for ACI Test using Discrete Components

11.3.4 Setup (using noise and interference test set method). This method uses the noise and interference test set to set the C/I of the adjacent channel interferers while also using a calibrated internal noise source to set the BER of the victim signal as illustrated in [Figure 11-8](#). A DQM reader/logger and BERT are used to collect the resulting DQM and BER values of the victim signal when subjected to adjacent interferers.

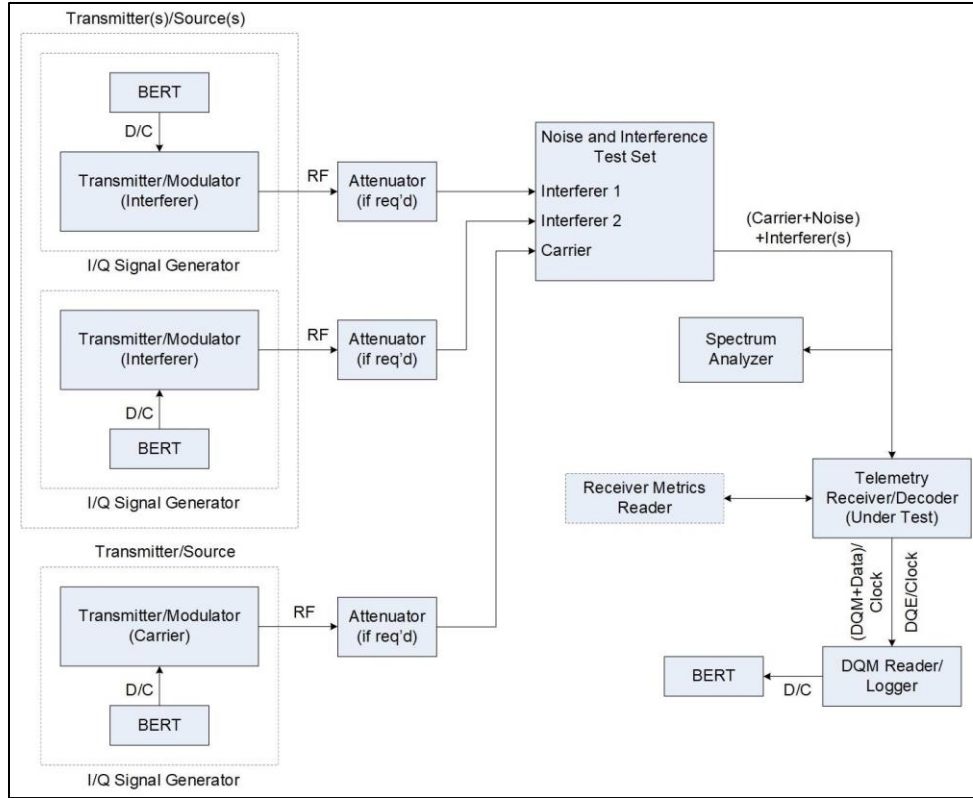

Figure 11-8. Setup for ACI Test using Noise and Interference Test Set

11.3.5 Setup (using receiver analyzer method). This method uses a receiver analyzer configured to derive the victim and interfering signals, set the C/I of the adjacent channel interferers, add noise to the victim signal resulting in a set BER, and capture and record DQM and BER values of the victim signal as illustrated in [Figure 11-9](#).

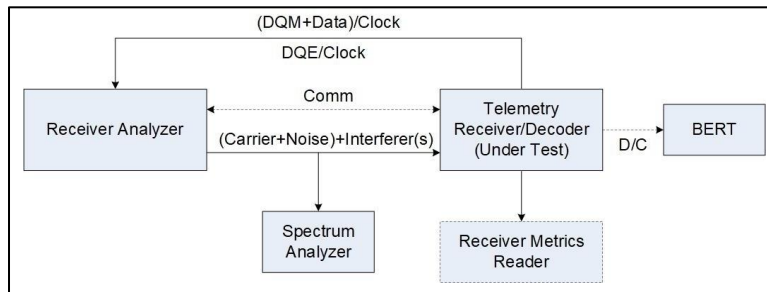

Figure 11-9. Setup for ACI Test using Receiver Analyzer

11.3.6 Conditions. This test can be performed using many combinations of carrier and interferers based upon modulation type, bit rate, coding, and operating TM band. The test can also be performed with one or two interferers. If using two interferers, place one above and one below the carrier frequency of the victim. Signal sources can be TM transmitter, laboratory signal generators, receiver analyzer, or any combination thereof. If possible, signal generator outputs should be passed through non-linear amplifiers to replicate the signal of a TM transmitter. If the purpose of the test is to evaluate receiver DQM performance representative of

an actual test mission with a specific set of frequencies, bit rates, coding, and modulation types, use these parameters for the test.

### 11.3.7 Procedure

1. Depending upon the source of the baseband data pattern, set the bit error test set or the internal data pattern of the carrier (C) or victim signal source to generate the desired bit rate with a pseudo-random bit sequence length of at least  $2^{11}-1$  bits. Configure the modulation (and coding if required) and center frequency of the modulator as required. The modulator output of the carrier will typically need to be non-linearly amplified to simulate a signal from a TM transmitter. Similarly, configure the other TM signal source(s) with independent pseudo-noise sequences at the desired bit rate and modulation mode. Non-linearly amplify the outputs if possible. If using non-TM signals as interferers, configure these interferers as required. Set the center frequencies of these signals to the desired locations above and below the frequency of the victim signal. A good starting point for placing TM signals in frequency around the carrier can be calculated using the ACI recommendations in 106-22 Appendix 2A. For non-TM signals, frequency spacing should emulate the real-world condition to be tested.
2. Determine a starting point for amount of additive noise for the carrier signal. Apply maximum attenuation or mute the RF output(s) of the interferer(s) to remove their influence on the signal level into the receiver. Ensure DQE is turned off in the receiver. Set the carrier level so the receiver is in its linear operating range. Adjust carrier + noise level that results in a BER of  $1 \times 10^{-5}$  from the TM receiver. This level can be set via attenuators and noise source level, set within the noise and interference test set, or set directly in the receiver analyzer depending upon the test setup. Once this level has been determined, increase the carrier level by 1 dB.
3. Using the spectrum analyzer (or power meter), set the relative powers of the interfering signal(s) compared to the carrier level. A typical starting point is to have the interfering signal(s) 20 dB larger ( $C/I = -20$  dB) than the victim signal, though this test can be conducted at any value of  $C/I$  as required. If using non-TM signals as interferers, the value of  $C/I$  should be consistent with values observed in the field. Turn on DQE on the receiver. Move the center frequency of the interferer(s) closer to the carrier until a BER of  $1 \times 10^{-5}$  from the TM receiver is once again achieved. This spacing is the point in which 1 dB of victim signal degradation occurs. For this fixed point, record the  $C/I$  value, center frequency offset of the interferer(s), and DQM value on Data Sheet 11-3.
4. Using the frequency offset resulting in  $BER = 1 \times 10^{-5}$  determined in step 3 as a center point, record DQM and BER values as the interferer(s) is dithered higher and lower in frequency around this point. Frequency offsets should be used that result in data from the receiver ranging between a BER of  $1 \times 10^{-2}$  and  $1 \times 10^{-7}$ . Record this information on Data Sheet 11-3. For each DQM value, calculate estimated BEP using the equations above and input these values on Data Sheet 11-3.
5. Repeat steps 1 through 4 for various combinations of carrier bit rates, modulation, coding, and center frequencies as required in order to characterize the receiver's DQM performance in the presence of adjacent interferers.

11.3.8 Data Reduction. There are two results from this testing. The first result is the DQM value obtained for the fixed frequency offset for the given C/I obtained in step 3. These values are recorded on Data Sheet 11-3. The second result is obtained when the interferer(s) frequency offsets are varied and the resulting DQM and BER are recorded. This tests the accuracy of the BEP estimate with ACI. As a function of interferer offset frequency, plot both BEP and BER on a linear-logarithmic X-Y scale to illustrate the results.

<b>Data Sheet 11-3. BER vs BEP with Adjacent Channel Interference</b>																																									
<b>Test 11.3</b>	<b>BER vs BEP with Adjacent Channel Interference</b>																																								
<b>Manufacturer:</b>	<b>Model:</b>																																								
<b>Serial No.:</b>																																									
<b>Test Personnel:</b>	<b>Date:</b>																																								
<p><b>Power level difference between Carrier &amp; Interferer(s), C/I _____ dB</b></p> <p>Receiver IF BW _____ MHz      DQM Value _____</p> <p>Carrier: Frequency _____ MHz      Bit rate _____ Mbps      Modulation _____</p> <p>Power _____ dBm      Code Rate: 1/2 2/3 4/5      Code Block: 1024 4096</p> <p>Interferer 1: Frequency _____ MHz      Bit rate _____ Mbps      Modulation _____</p> <p>Power: _____ dBm      Spacing from Carrier: _____ MHz</p> <p>Interferer 2: Frequency _____ MHz      Bit rate _____ Mbps      Modulation _____</p> <p>Power: _____ dBm      Spacing from Carrier: _____ MHz</p>																																									
<table border="1" style="width: 100%; border-collapse: collapse;"> <thead> <tr> <th style="width: 35%;">Interferer(s) Frequency Offset (MHz)</th> <th style="width: 15%;">BER</th> <th style="width: 15%;">DQM Value</th> <th style="width: 35%;">BEP</th> </tr> </thead> <tbody> <tr><td> </td><td> </td><td> </td><td> </td></tr> <tr><td> </td><td> </td><td> </td><td> </td></tr> <tr><td> </td><td> </td><td> </td><td> </td></tr> <tr><td> </td><td> </td><td> </td><td> </td></tr> <tr><td> </td><td> </td><td> </td><td> </td></tr> <tr><td> </td><td> </td><td> </td><td> </td></tr> <tr><td> </td><td> </td><td> </td><td> </td></tr> <tr><td> </td><td> </td><td> </td><td> </td></tr> <tr><td> </td><td> </td><td> </td><td> </td></tr> </tbody> </table>		Interferer(s) Frequency Offset (MHz)	BER	DQM Value	BEP																																				
Interferer(s) Frequency Offset (MHz)	BER	DQM Value	BEP																																						

## **DOM Test Methods Implementing the Telemetry Channel Model**

The dynamic multipath channel for aeronautical mobile TM is defined in 106-22 Appendix 2F.<sup>16</sup> [Chapter 10](#) describes the model and how to use it to construct both static and dynamic channel conditions. These channel conditions are created by varying parameters that define the impulse response of the channel. The equation for the impulse response is repeated in Equation 11-6. Refer to the introductory section of [Chapter 10](#) for a detailed discussion of the parameters used in Equation 11-6.

$$h(t) = \delta(t) + \Gamma_1 e^{-j2\pi f_c \tau_1} \delta(t - \tau_1) + \Gamma_2 e^{-j2\pi f_c \tau_2} \delta(t - \tau_2). \quad (\text{Eq. 11-6})$$

This test method will use the static channel conditions defined in [Chapter 10](#) using the definitions for the three propagation paths: LOS path, specular reflection path (path 1), and the diffuse reflection path (path 2). Static channel conditions are broken into two test conditions based upon the number of propagation paths.

The static 3-ray channel defines three channels with differing severity based upon the characteristics of the specular and diffuse reflections. The static 2-ray channel defines a test matrix of multiple configurations of  $\Gamma_1$ ,  $\tau_1$ , and  $\gamma_1$  that define the specular reflection. The 2-ray channel test matrix simplifies the 3-ray static channel by using only the specular reflection component but defines many more static channel conditions. (Note: The numerous test conditions of the 2-ray case lends itself to automated testing.)

For the static channel conditions, the phase  $\gamma_1$  for the specular reflection term is referenced to a null placed at the carrier frequency and then offset from that value. The phase value  $\gamma_1$  is stated in terms of delay ( $\tau_1$ ) and multiples ( $r$ ) of the bit rate ( $R_b$ ) for the waveform under test as shown in Equation 11-7. This places the multipath null created by the second ray at a fixed value from the carrier frequency in terms of the bit rate. This ensures the channel condition will affect the modulated signal.

$$\gamma_1 = 180^\circ \pm (360^\circ)\tau_1 r R_b. \quad (\text{Eq. 11-7})$$

For example, given a specular reflection delay of 50 ns, it is desired to have  $r = 0.2$  for  $R_b = 5$  Mbps resulting in the specular reflection null placed  $rR_b = 1$  MHz away from the carrier frequency. For this specular delay, the null cycles through  $360^\circ$  every 20 MHz (1/50 ns) or at a rate of  $18^\circ/\text{MHz}$ . The phase setting can then be calculated to be  $180^\circ \pm 18^\circ = 162^\circ$  or  $198^\circ$ .

### **Static 3-ray Channels**

#### **1. Channel 1 – Mild Impairment**

Specular Reflection Term:  $\Gamma_1 = -3.0$  dB,  $\tau_1 = 50$  ns,  $r = 0.55$

Diffuse Reflection Term:  $\Gamma_2 = -20$  dB,  $\tau_2 = 155$  ns,  $\gamma_2 = 90^\circ$

#### **2. Channel 2 – Moderate Impairment**

Specular Reflection Term:  $\Gamma_1 = -1.5$  dB,  $\tau_1 = 50$  ns,  $r = 0.1$

Diffuse Reflection Term:  $\Gamma_2 = -20$  dB,  $\tau_2 = 155$  ns,  $\gamma_2 = 90^\circ$

#### **3. Channel 3 – Severe Impairment**

Specular Reflection Term:  $\Gamma_1 = -1.0$  dB,  $\tau_1 = 50$  ns,  $r = 0$

---

<sup>16</sup> Range Commanders Council. “Use of Recommendation ITU-R M.1459 for Protection of...” Appendix 2F in *Telemetry Standards*. May 2022. Retrieved 5 October 2022. Available at <https://www.trmc.osd.mil/wiki/x/EoPOBg>.

Diffuse Reflection Term:  $\Gamma_2 = -20$  dB,  $\tau_2 = 155$  ns,  $\gamma_2 = 90^\circ$

#### Static 2-ray Channel - Test Matrix

Settings for Specular Reflection Term:

$\Gamma_1 = -3$  dB,  $-2.5$  dB,  $-1.5$  dB,  $-1$  dB,  $-0.5$  dB

$\tau_1 = 50$  ns,  $100$  ns,  $150$  ns

$r = 1$  to  $0$  in  $0.1$  steps

### **11.4. TEST: BER vs BEP for Static 3-Ray Multipath Channel Conditions**

11.4.1 Purpose. This test method provides a means to assess the ability of the receiver to provide an accurate assessment of signal quality in the presence of 3-ray multipath. The basis of comparison is BER versus estimated BEP (DQM) when the receiver is subjected to a signal corrupted with three static 3-ray multipath channel conditions of varying severity.

11.4.2 Test Equipment. There are three methods available for generating static multipath channels. The first is with a selection of RF components; the second is with a channel emulator; and the third is with a receiver analyzer that can implement multipath channel conditions. To simplify the testing, Either a channel emulator or receiver analyzer should be used for this test, as either simplifies testing.

- Fixed RF component method: Bit error test set, modulator (e.g., TM transmitter, I/Q signal source, etc.), method for setting signal  $E_b/N_0$ , delay lines, step attenuator (in  $0.1$ -dB steps), phase shifters, power dividers/combiners, receiver under test, DQM message reader, spectrum analyzer, internal receiver metric reader (optional)
- Channel emulator method: Bit error test set, modulator (e.g., TM transmitter, I/Q signal source, etc.), noise test set, channel emulator, receiver under test, DQM message reader, spectrum analyzer, internal receiver metric reader (optional)
- Receiver analyzer method: Receiver analyzer with DQM read and multipath generation capabilities, bit error test set (if required), receiver under test, spectrum analyzer, DQM message reader, spectrum analyzer, internal receiver metric reader (optional)

11.4.3 Setup (using discrete RF components). This method uses discrete components to derive the multipath channel conditions for this test. A noise source is used to set  $E_b/N_0$  of the signal after it is generated. Attenuators are used for setting  $\Gamma_1$  and  $\Gamma_2$ , delay lines for  $\tau_1$  and  $\tau_2$ , and phase shifters for  $\gamma_1$  and  $\gamma_2$ . Power dividers/combiners are required to divide the generated signal into three paths, then to sum the three rays after the multipath conditions are applied. A DQM reader/logger and BERT are used to collect the resulting DQM and BER values of the signal when subjected to the 3-ray multipath channel. This setup is shown graphically in [Figure 11-10](#).

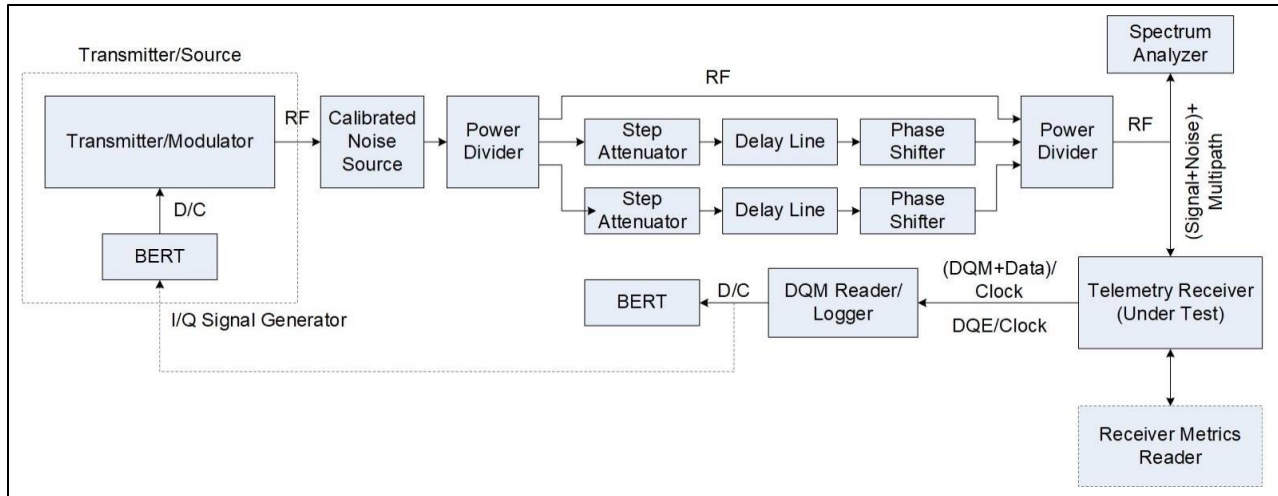

Figure 11-10. Setup for Static 3-ray Multipath Channel Conditions using Discrete Components

11.4.4 Setup (using channel emulator). This method places the channel emulator between the signal source and the receiver under test. The channel emulator allows direct control over the channel parameters ( $\Gamma_1$ ,  $\tau_1$ ,  $\Gamma_2$ ,  $\tau_2$ , and  $\gamma_1$ ,  $\gamma_2$ ) for each of the 3-rays used to create the fixed multipath conditions for this test. A noise test set is used to set  $E_b/N_0$  to 20 dB for the test signal prior to being subjected to multipath by the channel emulator. A DQM reader/logger and BERT are used to collect the resulting DQM and BER values of the signal when subjected to the 3-ray multipath channel. This figure is shown graphically in [Figure 11-11](#).

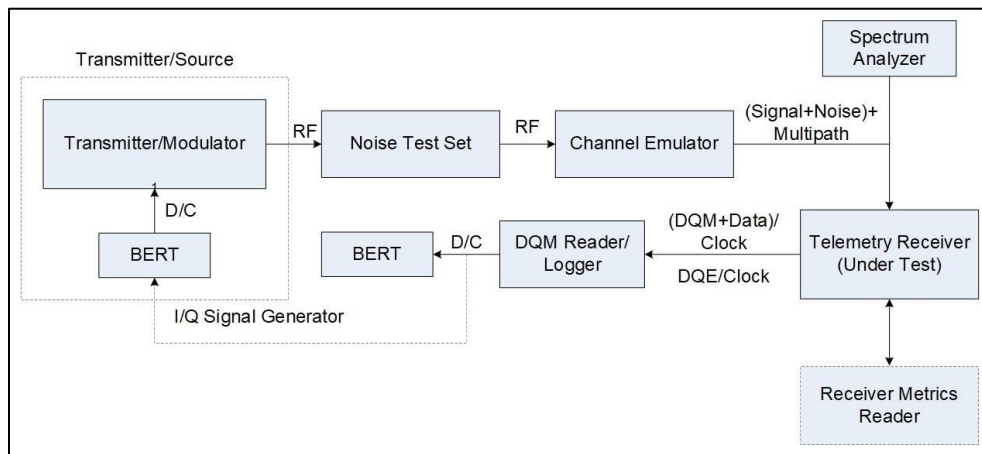

Figure 11-11. Setup for Static 3-ray Multipath Channel Conditions using Channel Emulator

11.4.5 Setup (using receiver analyzer). This method uses a receiver analyzer to create both the desired waveform and the static channel conditions in one unit. The output of the receiver analyzer is the waveform with  $E_b/N_0$  set to 20 dB with the static channel condition already applied. As with the channel emulator, direct control over the channel parameters ( $\Gamma_1$ ,  $\tau_1$ ,  $\Gamma_2$ ,  $\tau_2$ , and  $\gamma_1$ ,  $\gamma_2$ ) for each of the 3-rays is available within the receiver analyzer. A receiver analyzer with this test capability will also have the capability to read the input DQE message, log/display the DQM values, and log/display BER statistics. This figure is shown graphically in [Figure 11-12](#).



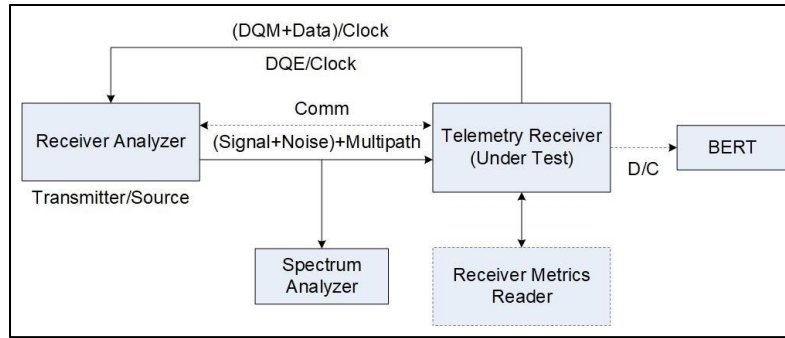

Figure 11-12. Setup for Static 3-ray Multipath Channel Conditions using Receiver Analyzer

11.4.6 **Conditions.** This test can be performed with any combination of modulation, bit rate, coding, and operating TM band coupled with a method of creating the fixed 3-ray multipath channel condition. The receiver DQM response can be tested with and without equalization enabled (if available). The test signal can be generated with actual TM transmitters or with appropriate laboratory signal generators and/or a receiver analyzer. The laboratory generators should be passed through a non-linear amplifier to replicate the signal of a TM transmitter. Lastly, the resulting BER and DQM values for each channel condition need to be recorded.

#### 11.4.7 Procedure

1. Depending upon the source of the baseband data pattern, set the bit error test set or the internal data pattern of the signal source to generate the desired bit rate with a pseudo-random bit sequence length of at least  $2^{11}-1$  bits, preferably  $2^{31}-1$  bits long. The longer sequence is a better simulation of the characteristics of an encrypted baseband signal.
2. Configure the modulation (and coding if required) and center frequency of the modulator as required. The modulator output of the carrier will typically need to be non-linearly amplified to simulate a signal from a TM transmitter. As a quick check, use a spectrum analyzer to verify the signal spectrum matches the expected modulated waveform. If using a receiver analyzer, the BERT pattern, bit rate, carrier frequency, modulation, and coding schemes are set in this one unit.
3. Using the noise test set, channel emulator, or receiver analyzer, set  $E_b/N_0 = 20$  dB using the OTA bit rate as the bit rate for determining  $E_b/N_0$ . If using the channel emulator, set the output level of the noise test set to match the operating input level required for the channel emulator. Set  $E_b/N_0 = 20$  dB directly within the receiver analyzer.
4. Set the receiver to match the combination of bit rate, carrier frequency, and modulation/coding scheme chosen for the test. Connect a BERT to the output of the receiver. Ensure DQE is not enabled on the output of the receiver.
5. Connect the modulator/noise test set to the receiver through either the channel emulator or discrete RF components. If using a channel emulator, ensure the selected bandwidth is of sufficient width to accommodate the modulation/coding scheme being tested. If using a receiver analyzer, directly connect it to the receiver. To verify end-to-end connection between the modulator and receiver, configure only the LOS direct path. If using RF components, this is as simple as connecting the modulator and receiver together with a coaxial cable. If using a channel emulator, enable the LOS path (direct path) with unity gain,

zero delay, and zero phase shift. If using a receiver analyzer, disable the multipath function. Verify that the bit error test set synchronizes on the correct pseudo-noise bit sequence.

6. Enable DQE on the receiver. Verify the equipment being used to read and capture DQM values and BER with DQE enabled are functioning properly. If possible, DQM and BER values should be captured coincidentally.
7. Connect the remainder of the discrete RF components to create the specular and diffuse reflections creating the composite 3-ray multipath channel. If using a channel emulator, enable the specular (path 1) and diffuse (path 2) reflections. If using a receiver analyzer, enable the multipath function.
8. Configure the multipath setup for mild impairment (Channel 1) as defined above for the static 3-ray channel. Allow enough time during the channel condition so a valid average of DQM and BER can be determined. Annotate the final values on the data sheet. Record the static channel condition, value of BER, and DQM value on Data Sheet 11-4.
9. Repeat step 8 for the moderate (channel 2) and severe (channel 3) static 3-ray channel conditions.
10. Repeat steps 8 and 9 with differing bit rates, modulation (coding scheme as required), equalization (if available), and carrier frequency as required.

11.4.8 Data Reduction. Each BER and BEP result is a measure of the multipath sensitivity of the SUT. Using the above equations, convert the DQM values to BEP in Data Sheet 11-4. Compare the measured BER value versus the BEP for each 3-ray multipath channel condition by plotting the data on a logarithmic-logarithmic X-Y scale.

<b>Data Sheet 11-4. BER vs BEP for Static 3-Ray Multipath Channel Conditions</b>																					
<b>Test 11.4</b>	<b>BER vs BEP for Static 3-Ray Multipath Channel Conditions</b>																				
Manufacturer:	Model:																				
Serial No.:																					
Test Personnel:	Date:																				
<p>Center Frequency (MHz): _____ Modulation/Coding Mode: _____</p> <p>Uncoded Bit Rate (Mbps): _____ DQE Payload (bits): _____</p> <p>Coding Rate: 1/2 2/3 4/5 Code Block: 1024 4096 Equalization Enabled: YES NO</p> <p>Time at Channel Condition (ms): _____ 99% OBW: _____ MHz</p>																					
<table border="1" style="margin: auto; border-collapse: collapse;"> <thead> <tr> <th style="padding: 5px;">Static 3-ray Channel Condition</th> <th style="padding: 5px;">BER</th> <th style="padding: 5px;">DQM</th> <th style="padding: 5px;">BEP</th> </tr> </thead> <tbody> <tr><td style="height: 20px;"> </td><td> </td><td> </td><td> </td></tr> <tr><td style="height: 20px;"> </td><td> </td><td> </td><td> </td></tr> <tr><td style="height: 20px;"> </td><td> </td><td> </td><td> </td></tr> <tr><td style="height: 20px;"> </td><td> </td><td> </td><td> </td></tr> </tbody> </table>		Static 3-ray Channel Condition	BER	DQM	BEP																
Static 3-ray Channel Condition	BER	DQM	BEP																		

## 11.5. TEST: BER vs BEP for Static 2-Ray Multipath Channel Conditions

11.5.1 Purpose. This test method provides a means to assess the ability of the receiver to provide an accurate assessment of signal quality in the presence of 2-ray multipath. The basis of comparison is BER versus estimated BEP (DQM) when the receiver is subjected to a signal corrupted with combinations of static 2-ray multipath channel conditions of varying severity.

11.5.2 Test Equipment. There are three methods available for generating static multipath channels. The first method is with a selection of discrete RF components. Given the large number of combinations of amplitude, delay, and phase of the specular component (path 1) for each bit rate or carrier frequency for this test, performing this test with individual RF components is not recommended. The second method is performed with a channel emulator as it is perfectly suited for this type of multipath testing. The last method is performed with a receiver analyzer that is capable of deriving these 2-ray channel conditions.

- Channel emulator method: Bit error test set, modulator (e.g. TM transmitter, I/Q signal source, etc.), noise test set, channel emulator, receiver under test, DQM message reader, spectrum analyzer, internal receiver metric reader (optional)
- Receiver analyzer method: Receiver analyzer with DQM read and multipath generation capabilities, bit error test set (if required), receiver under test, spectrum analyzer, DQM message reader, spectrum analyzer, internal receiver metric reader (optional)

11.5.3 Setup (using channel emulator). This method places the channel emulator between the signal source and the receiver under test as shown in [Figure 11-13](#). The channel emulator allows direct control over the channel parameters ( $\Gamma_1$ ,  $\tau_1$ ,  $\Gamma_2$ ,  $\tau_2$ , and  $\gamma_1$ ,  $\gamma_2$ ) that create the multiple 2-ray multipath conditions. A noise test set is used to set a value of  $E_b/N_0$  for the test signal prior to being subjected to multipath by the channel emulator. A DQM reader/logger and BERT are used to collect the resulting DQM and BER values of the signal when subjected to the 2-ray multipath channel.

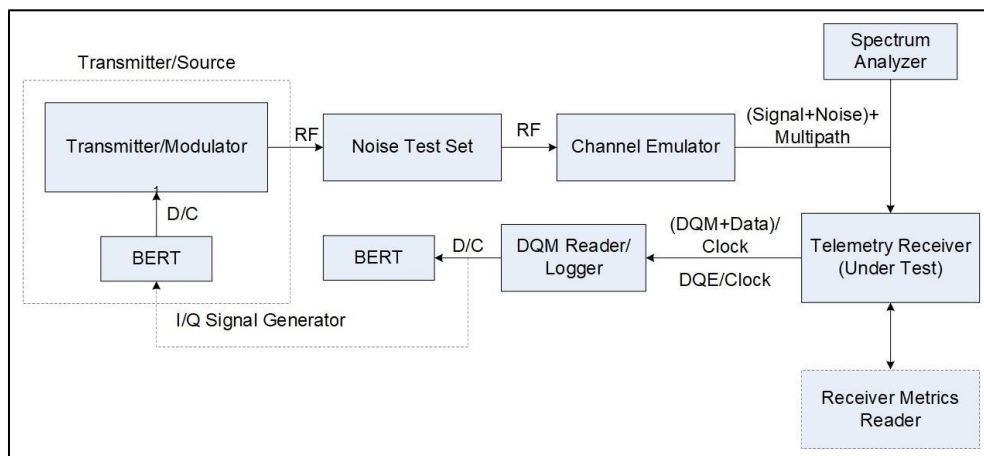

Figure 11-13. Setup for Static 2-ray Multipath Channel Conditions using Channel Emulator

11.5.4 Setup (using receiver analyzer). This method uses a receiver analyzer to create both the desired waveform and the static channel conditions in one unit. The output of the receiver

analyzer is the waveform with  $E_b/N_0$  set to 20 dB with the static channel condition already applied. As with the channel emulator, direct control over the channel parameters ( $\Gamma_1$ ,  $\tau_1$ , and  $\gamma_1$ ) for the specular reflection path (path 1) is available within the receiver analyzer. A receiver analyzer with this test capability will also have the capability to read the input DQE message, log/display the DQM values, and log/display BER statistics. [Figure 11-14](#) illustrates this setup.

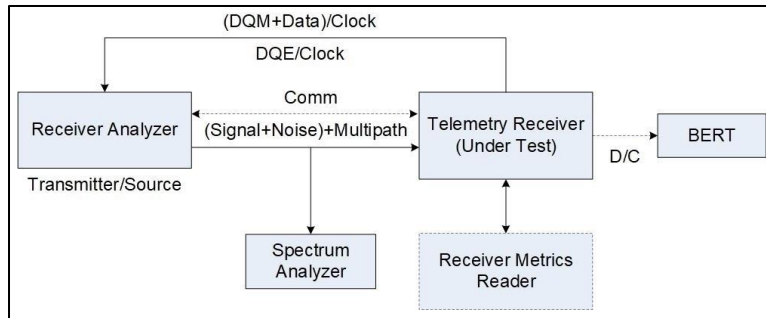

Figure 11-14. Setup for Static 2-ray Multipath Channel Conditions using Channel Emulator

**11.5.5 Conditions.** This test can be performed with any combination of modulation, bit rate, coding, and operating TM band coupled with a method of creating the multiple combinations of fixed 2-ray multipath channel conditions. The receiver DQM response can be tested with and without equalization enabled (if available). The test signal can be generated with actual TM transmitters or with appropriate laboratory signal generators and/or a receiver analyzer. The laboratory generators should be passed through a non-linear amplifier to replicate the signal of a TM transmitter. Lastly, the resulting BER and DQM values for each channel condition need to be logged and recorded.

#### 11.5.6 Procedure

1. Set the bit error test set or source pattern to generate the desired bit rate with a pseudo-noise bit sequence length of at least  $2^{11}-1$  bits and preferably  $2^{31}-1$  bits long. Set the signal source to generate the required modulation and coding scheme (if required) at the chosen carrier frequency. (If not using a TM transmitter, amplify the signal with a non-linear amplifier if available). As a quick check, use a spectrum analyzer to verify the signal spectrum matches the expected modulated waveform at the specified bit rate. If using a receiver analyzer the bit pattern, bit rate, carrier frequency, modulation, and coding scheme are set in this one unit.
2. Using the noise test set, channel emulator, or receiver analyzer, set  $E_b/N_0 = 20$  dB using the OTA bit rate as the bit rate for determining  $E_b/N_0$ . If using the channel emulator, set the output level of the noise test set to match the operating input level required for the channel emulator. Set  $E_b/N_0 = 20$  dB directly within the receiver analyzer.
3. Set the receiver to match the combination of bit rate, carrier frequency, and modulation/coding scheme chosen for the test. Connect the BERT to the output of the receiver.
4. Connect the modulator/noise test set to the receiver through the channel emulator, ensuring the selected bandwidth is of sufficient width to pass the test signal. If using a receiver analyzer, directly connect it to the receiver/equalizer. To verify end-to-end connection between the modulator and receiver, configure only the LOS direct path. If using a channel emulator, enable the LOS path with unity gain, zero delay, and zero phase shift or enable the

pass-through function if available. If using a receiver analyzer, disable the multipath function. Verify that the BERT synchronizes on the correct pseudo-noise bit sequence.

5. Enable DQE on the receiver. Verify the equipment being used to read and capture DQM values and BER with DQE enabled are functioning properly.
6. If using a channel emulator, enable the specular reflection (path 1). If using a receiver analyzer, enable the multipath function for a 2-ray multipath condition.
7. There are 165 individual 2-ray channel conditions specified for this test, though not all need to be tested. For each delay  $\tau_1$ , the phase shift  $\gamma_1$  needs to be calculated for each value of  $r$  knowing the bit rate (or OTA bit rate if coding is implemented)  $R_b$  for the test. The following is one suggested method for running through the test matrix for the multiple 2-ray channel conditions.
  - a. In the noise test set, set the proper carrier frequency and bit rate or OTA bit rate ( $R_b$ ) if coding is implemented. Set  $E_b/N_0 = 20$  dB. Ensure the noise bandwidth in the noise test set is correctly set given the combination of modulation and coding scheme and bit rate. Set the same parameters in the receiver analyzer if appropriate.
  - b. Set the LOS path to unity gain ( $\Gamma = 0$  dB), with zero delay ( $\tau = 0$  ns) and zero phase shift ( $\gamma = 0^\circ$ ).
  - c. Select a value of amplitude for the specular reflection (path 1). The values for  $\Gamma_1$  can be  $-3$  dB,  $-2.5$  dB,  $-1.5$  dB,  $-1$  dB, or  $-0.5$  dB.
  - d. Select a value of delay for the specular reflection (path 1). The values for  $\tau_1$  can be 50 ns, 100 ns, or 150 ns.
  - e. For the value of delay ( $\tau_1$ ) chosen, calculate the phase shift ( $\gamma_1$ ) using the bit rate ( $R_b$ ) for each value of  $r$  using Equation 11-8. The values for  $r$  can be 0-1.0 in 0.1 steps (11 values). Record the calculated phase shifts ( $\gamma_1$ ) for each value of  $r$ .

$$\gamma_1 = 180^\circ \pm (360^\circ)\tau_1 r R_b. \quad (\text{Eq. 11-8})$$

- f. At each value of  $r$ , allow enough time during the channel condition so a valid average of DQM and BER can be determined. Record these values along with the settings for  $\Gamma_1$ ,  $\tau_1$ , and  $\gamma_1$  on Data Sheet 11-5. If possible, BER and DQM values should be captured coincidentally throughout the testing.
  - g. After each of the 11 values of  $r$  have been tested, repeat the procedure starting at step c and ending at step f for all remaining values of amplitudes  $\Gamma_1$  and delays  $\tau_1$ . For all of these 2-ray multipath channel conditions, record the resulting BER and DQM values along with the settings for  $\Gamma_1$ ,  $\tau_1$ , and  $\gamma_1$  on Data Sheet 11-5.
6. Repeat the procedure, steps 7a through 7g for different values of carrier frequency, modulation, coding, equalization (if available), and bit rate ( $R_b$ ) as required.

11.5.7 Data Reduction. The BER result is a measure of the 2-ray multipath sensitivity of the SUT. The DQM/BEP results, when compared to the BER results, indicates how well the receiver estimates the multipath distortion. Using the above equations, convert the DQM values to BEP in Data Sheet 11-5. Compare the measured BER value versus the BEP for each combination of amplitude ( $\Gamma_1$ ) and delay ( $\tau_1$ ) coupled with the 11 values of phase ( $\gamma_1$ ) for the specular reflection.

The results of each 2-ray multipath channel condition tested can be illustrated plotting BER vs BEP on a logarithmic-logarithmic X-Y scale.

Data Sheet 11-5. BER vs BEP for Static 2-Ray Multipath Channel Conditions																																																																		
<b>Test 11.5</b>	<b>BER vs BEP for Static 2-Ray Multipath Channel Conditions</b>																																																																	
Manufacturer:	Model:																																																																	
Serial No.:																																																																		
Test Personnel:	Date:																																																																	
<p>Center Frequency (MHz): _____ Modulation/Coding Mode: _____</p> <p>Uncoded Bit Rate (Mbps): _____ DQE Payload (bits): _____</p> <p>99% OBW (MHz): _____ Equalization Enabled: YES NO</p> <p style="text-align: center;">Coding Rate: 4/5 2/3 1/2 Block Size: 1024 4096</p> <p>2-Ray Channel Condition: Amplitude (<math>\Gamma_1</math>) (dB): _____ Delay (<math>\tau_1</math>) (ns): _____</p>																																																																		
<table border="1" style="margin: auto; border-collapse: collapse; width: 80%;"> <thead> <tr> <th style="padding: 5px;">Multiple (<math>r</math>)</th> <th style="padding: 5px;">Phase Shift (<math>\gamma_1</math>)</th> <th style="padding: 5px;">BER</th> <th style="padding: 5px;">DQM</th> <th style="padding: 5px;">BEP</th> </tr> </thead> <tbody> <tr><td style="text-align: center;">0.0</td><td></td><td></td><td></td><td></td></tr> <tr><td style="text-align: center;">0.1</td><td></td><td></td><td></td><td></td></tr> <tr><td style="text-align: center;">0.2</td><td></td><td></td><td></td><td></td></tr> <tr><td style="text-align: center;">0.3</td><td></td><td></td><td></td><td></td></tr> <tr><td style="text-align: center;">0.4</td><td></td><td></td><td></td><td></td></tr> <tr><td style="text-align: center;">0.5</td><td></td><td></td><td></td><td></td></tr> <tr><td style="text-align: center;">0.6</td><td></td><td></td><td></td><td></td></tr> <tr><td style="text-align: center;">0.7</td><td></td><td></td><td></td><td></td></tr> <tr><td style="text-align: center;">0.8</td><td></td><td></td><td></td><td></td></tr> <tr><td style="text-align: center;">0.9</td><td></td><td></td><td></td><td></td></tr> <tr><td style="text-align: center;">1.0</td><td></td><td></td><td></td><td></td></tr> <tr><td></td><td></td><td></td><td></td><td></td></tr> </tbody> </table>		Multiple ( $r$ )	Phase Shift ( $\gamma_1$ )	BER	DQM	BEP	0.0					0.1					0.2					0.3					0.4					0.5					0.6					0.7					0.8					0.9					1.0									
Multiple ( $r$ )	Phase Shift ( $\gamma_1$ )	BER	DQM	BEP																																																														
0.0																																																																		
0.1																																																																		
0.2																																																																		
0.3																																																																		
0.4																																																																		
0.5																																																																		
0.6																																																																		
0.7																																																																		
0.8																																																																		
0.9																																																																		
1.0																																																																		



## 11.6. TEST: DQM (BEP) Resynchronization Response

11.6.1 Purpose. This test method provides a means to characterize the receiver's signal quality estimate during a resynchronization event. The purpose is to investigate any anomalous DQM values output by the receiver during resynchronization. The basis of comparison is the DQM value before, during, and after a resynchronization event as the input signal to the receiver will have a known, fixed signal quality.

11.6.2 Test Equipment. The test equipment used in this test are similar to Test Method 11.1 with several key additions. The resynchronization test is performed with two types of input signals to the receiver under test: signal (at a very high value of  $E_b/N_0$ ) then wideband noise; and signal plus noise (at a set  $E_b/N_0$  to arrive at a known BER) then wideband noise. To accomplish this switching, an RF switch is added to the test configuration. The switching is controlled using a function generator. If required, resynchronization time can be measured with a digital oscilloscope. If the actual resynchronization time is not measured, the baseband pattern can be a pseudo-noise bit sequence as opposed to randomized 1's. A receiver analyzer implementing this test method replaces much of the test equipment and associated test setup components. The DQM values before, during, and after the switch are captured and recorded for further analysis.

- Step attenuator/power meter method: Bit error test set, modulator (e.g., TM transmitter, I/Q signal source, etc. with required coding as necessary, IRIG randomizer), power meter, electronically controlled step attenuator (in 0.1 dB steps for LDPC coded signals), RF switch, function generator (for step and dwell timing), noise source, spectrum analyzer, digital oscilloscope (optional), DQM message reader/logger, receiver metric reader (optional)
- Noise test set method: Bit error test set, modulator (e.g., TM transmitter, I/Q signal source, etc. with required coding as necessary, IRIG randomizer), noise test set, RF switch, function generator (for signal switching), noise source, DQM message reader/logger, spectrum analyzer, digital oscilloscope (optional), receiver metric reader (optional)
- Receiver analyzer method: Receiver analyzer with DQM read capability and ability to vary the time between signal and noise or (signal + noise) and noise, bit error test set (if required), spectrum analyzer, digital oscilloscope (optional), receiver metric reader (optional)

11.6.3 Setup (step attenuator/power meter method). This method is for manually setting  $E_b/N_0$  by using the combination of input signal level and internal receiver noise to calibrate the carrier-to-noise level. Refer to section 11.1.3 steps 1-5 for details on determining the step attenuator value for setting  $E_b/N_0 = 10$  dB. Once the step attenuator value is known, the test configuration is very similar to [Figure 11-15](#) (without the noise test set). The function generator provides the timing to the RF switch, triggers the oscilloscope, and provides a time mark to the DQM reader/logger and receiver metric reader (if available). The signal level to the receiver under test should be roughly equal when switching between (signal + noise) and noise. The signal source uses IRIG randomized 1's as the baseband data pattern prior to modulation/ coding. After demodulation/decoding, IRIG de-randomization is accomplished in the receiver prior to outputting the data (all 1's).

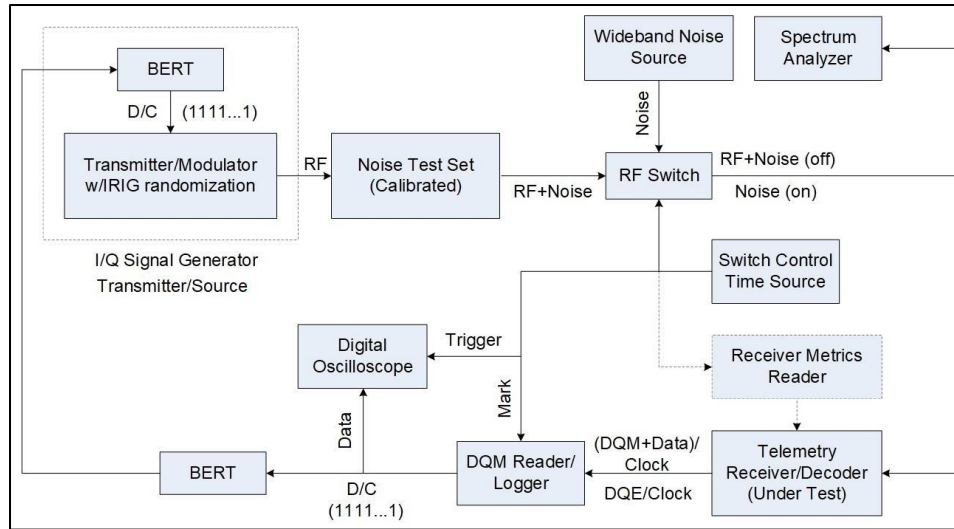

Figure 11-15. Setup for Resynchronization Response using Noise Test Set

11.6.4 Setup (for noise test set method). This method is for utilizing a noise test set for directly setting  $E_b/N_0$  prior to the RF switch. Once the bit rate and noise bandwidth are set in the noise test set, the signal from the transmitting source is applied and the noise test set will measure carrier power, allowing direct control over  $E_b/N_0$  by varying the amount of calibrated noise  $N$ . The signal level to the receiver under test should be roughly equal when switching between (signal + noise) and noise. The function generator provides the timing to the RF switch, triggers the oscilloscope, and provides a time mark to the DQM reader/logger and receiver metric reader (if available). The signal source uses IRIG randomized 1's as the baseband data pattern prior to modulation/coding. After demodulation/decoding, IRIG de-randomization is accomplished in the receiver prior to outputting the data (all 1's).

11.6.5 Setup (for receiver analyzer method). This method utilizes a receiver analyzer for generating the TM waveform with IRIG randomized 1's as the baseband data pattern, setting  $E_b/N_0$  directly, controlling switching of RF between (signal + noise) and noise, and logging the resulting DQM values as shown in [Figure 11-16](#). Receiver analyzers that have this test capability will require configuration of the signal source (bit pattern and rate, modulation, coding) and of the test to be performed (in this case DQM resynchronization response). After these steps, the receiver analyzer will switch between (waveform under test + noise) and noise at the set switching frequency then input the DQE message from the receiver, calculate resynchronization time, and finally capture and record the DQM values during the resynchronization events. If the receiver analyzer can only perform portions of the complete test, refer to [Figure 11-16](#) for the functional block diagram of this test method. Note: If resynchronization time cannot be measured with the receiver analyzer directly, the analyzer will have to output the RF switching signal in order to trigger the digital oscilloscope.

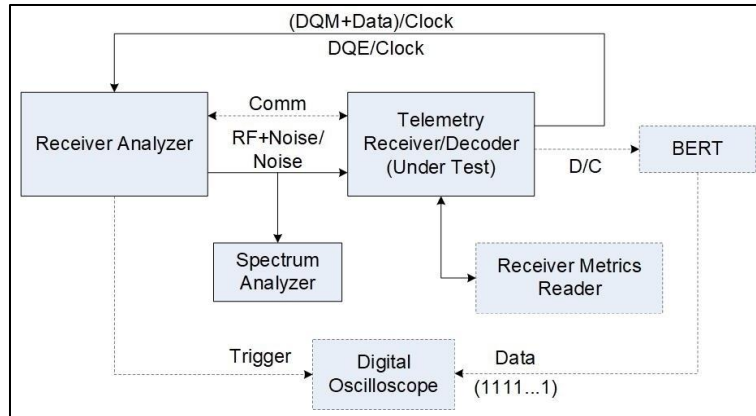

Figure 11-16. Setup for Resynchronization Response using Receiver Analyzer

11.6.6 Conditions. This test can be performed using any of the three setups that perform the following:

- A waveform/coding signal source using IRIG randomized 1's as the baseband data pattern followed by manually determining and setting  $E_b/N_0$ , RF switch controlled by a function generator switching between (signal + noise) and noise of equal power levels, digital oscilloscope measuring the resynchronization time, and ability to capture and record the resulting DQM values during the resynchronization event;
- A waveform/coding signal source using IRIG randomized 1's as the baseband data pattern followed by a noise test set that generates the signal at the selected  $E_b/N_0$  directly, RF switch controlled by a function generator switching between (signal + noise) and noise of equal power levels, digital oscilloscope measuring the resynchronization time, and ability to capture and record the resulting DQM values during the resynchronization event;
- An integrated waveform/coding signal source using IRIG randomized 1's as the baseband data source with calibrated additive noise source (e.g., receiver analyzer), allows for selecting RF on/off times between (signal + noise) and noise, directly measure receiver resynchronization time, capture and record the resulting DQM values during the resynchronization event.

If a TM transmitter (or a suitable substitute) is not used as the signal source, the signal should be non-linearly amplified to better reflect detection performance.

#### 11.6.7 Procedure

1. Set the bit error test set or source pattern to generate IRIG randomized an all 1's (or all 0's) pattern. This can be accomplished directly or for example by selecting all 1's internal data and turning on the IRIG randomizer in a TM transmitter. (Note: The BERT can also be set to generate the desired bit rate with a pseudo-noise sequence length of  $2^{15}-1$  bits with the sequence generated using feedback from register taps 14 and 15. A  $2^{15}-1$  bit length sequence can be used for this test because it is compatible with the 15-stage IRIG randomizer/de-randomizer. Coupled with de-randomization on the receiver, this combination will result in all 1's at the output of the receiver). If a resynchronization time measurement is not required, the baseband data pattern can be a pseudo-noise bit sequence. Set the signal source to

generate the required modulation/coding scheme (if applicable) at the required carrier frequency. (If available, amplify the signal with a non-linear amplifier if a TM transmitter or receiver analyzer is not used as the signal source). Verify the expected output with the spectrum analyzer. If using a noise test set, select pass-through so the test signal is not affected by the test set.

2. Set the signal and wideband noise levels to be approximately the same amplitude on the output of the RF switch. This can be set internally on the receiver analyzer or externally by measuring the output of the RF switch with a spectrum analyzer. Set the switch control time source (function generator) for a 50% duty cycle at 0.5 Hz and adjust the signal and wideband noise levels accordingly. The level should be in the linear input range of the receiver input. Note: The “off” condition of the RF switch should pass the signal/(signal + noise) and not the wideband noise.
3. Set the receiver under test to receive and de-randomize the input signal by setting the modulation/coding, center frequency, and selecting de-randomization. At this point, DQE in the receiver is not yet enabled. The output should be all 1’s (or 0’s) if there are no bit errors. Any bit errors will show up as 0’s (or 1’s) in the de-randomized output. The receiver/demodulator output can be verified with the digital oscilloscope or the BERT connected to the data/clock output. Note: Some demodulators output the zero state when the demodulator is out of synchronization. In this case, it is preferable to randomize 1’s or invert the data output to determine the error-free state from the out-of-synchronization state. Note: If resynchronization time is not measured and a pseudo-noise bit sequence is used, the above is not applicable.
4. As an initial RF switching configuration, set the function generator so the RF switch passes the signal/(signal + noise) for about 2 seconds and the wideband noise signal for about 8 seconds in a pattern that repeats every 10 seconds. Trigger the digital oscilloscope on the transition from noise to signal/(signal + noise) and record 10-second intervals to correspond with the complete RF switching cycle on the DQM reader. Record the times in which the signal and noise are present on Data Sheet 11.6.
5. Set the required  $E_b/N_0$  (as set by the step attenuator, noise test set, or receiver analyzer) for the input test signal given the modulation/coding. Record the expected BER and BEP values for this setting of  $E_b/N_0$  as determined in Test 11.1 on Data Sheet 11.6.
6. Enable DQE on the receiver and verify the DQM reader is capturing and recording DQM (BEP) values before, during, and after the resynchronization time mark (trigger signal).
7. Measure resynchronization time by comparing the difference in time between when the RF switches from noise to signal (time mark/trigger signal) to when the receiver outputs all 1’s (or all 0’s). Record this resynchronization time, in number of bits, on Data Sheet 11-6. Note: If the DQM reader is outputting data and clock and not a DQE formatted bit stream, resynchronization time can be measured at the output of the DQM reader. If the DQM reader is only reading and recording DQM values, resynchronization time will have to be measured at the receiver output with DQE disabled.
8. Repeat steps 4 through 7 with a differing value of  $E_b/N_0$ . Note: As noise increases (smaller values of  $E_b/N_0$ ), determining when the receiver/demodulator resynchronizes can be difficult

as all 1's and all 0's are no longer the output. Increase or decrease RF switching time as required.

11.6.8 Data Reduction. There are three results from this testing. The first result shows how well BEP correlates with the expected BER during a resynchronization event based upon the measurement results obtained in Test 11.1. The second result shows any anomalous behavior of DQM values during a resynchronization event that could adversely affect a downstream best source selector. Third, the resynchronization time of the receiver/demodulator can be measured. This test is not as comprehensive as the test described in Test 7.4 but does provide an indication of resynchronization time with and without noise added to the signal.

In the logged files, convert the captured DQM values to estimated BEP using the above equations. To illustrate the DQM resynchronization response, plot the BEP estimates for one RF switch cycle (per step 4 above). This will illustrate the response before, during, and after the resynchronization time mark in the log file. If the log file does not contain the time mark, time align log data with the trigger signal to the digital oscilloscope. Compare the BEP value with the BER value for the set value of  $E_b/N_0$  as obtained in Test 11.1. The illustration of the response will plot calculated BEP and measured BER values using a linear-logarithmic X-Y scale with RF switch cycle time on the X-axis for each  $E_b/N_0$  setting.

<b>Data Sheet 11-6. DQM (BEP) Resynchronization Response</b>																	
<b>Test 11.6</b>	<b>DQM (BEP) Resynchronization Response</b>																
Manufacturer:	Model:																
Serial No.:																	
Test Personnel:	Date:																
Center Frequency: _____ MHz      Modulation: _____																	
Uncoded Bit Rate: _____ Mbps      Coded Bit Rate: _____ Mbps																	
Coding Rate: 1/2 2/3 4/5    Code Block: 1024 4096    DQE Payload: _____ bits																	
RF ON Time: _____      RF OFF Time: _____																	
<table border="1" style="margin: auto; border-collapse: collapse;"> <thead> <tr> <th style="padding: 5px;"><math>E_b/N_0</math> (dB)</th> <th style="padding: 5px;">Expected BER</th> <th style="padding: 5px;">Expected BEP</th> <th style="padding: 5px;">Resync Time (in bits)</th> </tr> </thead> <tbody> <tr> <td style="height: 20px;"></td> <td></td> <td></td> <td></td> </tr> <tr> <td style="height: 20px;"></td> <td></td> <td></td> <td></td> </tr> <tr> <td style="height: 20px;"></td> <td></td> <td></td> <td></td> </tr> </tbody> </table>		$E_b/N_0$ (dB)	Expected BER	Expected BEP	Resync Time (in bits)												
$E_b/N_0$ (dB)	Expected BER	Expected BEP	Resync Time (in bits)														

## Appendix A

### IM Products and Intercept Point

#### A.1 General

These notes are presented to point out a severe problem in systems involving preamplifiers. The IM products are produced whenever the signal strength is sufficient to cause the amplifier (or receiver) to operate in the nonlinear portion of the characteristics of the unit. A major cause of IM is gain compression. Because of a limited range of linear operation, the IM products of neighboring signals are very likely to fall on top of the desired signal, many times resulting in complete loss of data. A brief mathematical discussion of the factors involved in the production of objectionable IM components with two input signals is presented as a way of introducing the problem. The IM noise can also distort the signal by entering the transmission path and modulating the signal or it can be caused by nonlinear characteristics of the electrical components.

#### A.2 Intermodulation Products

The output of an amplifier can be expressed as a power series with:

$$e_{out} = k_1 e_{in} + k_2 e_{in}^2 + k_3 e_{in}^3 + \dots \text{higher-order terms that are considered negligible for this analysis.}$$

If  $e_{in} = (e_1 \sin \omega_1 t + e_2 \sin \omega_2 t)$ , expansion is shown to yield the following equations in the output:

$$e_{out} = \frac{1}{2} k_2 (e_1^2 + e_2^2) \tag{Eq. A-1}$$

$$+ [k_1 e_1 + \frac{3}{2} k_3 e_1 e_2^2 + \frac{3}{4} k_3 e_1^3] \sin \omega_1 t \tag{Eq. A-2}$$

$$+ [k_1 e_2 + \frac{3}{2} k_3 e_1^2 e_2 + \frac{3}{4} k_3 e_2^2] \sin \omega_2 t \tag{Eq. A-3}$$

$$- \frac{1}{2} k_2 e_1^2 \cos 2\omega_1 t \tag{Eq. A-4}$$

$$- \frac{1}{2} k_2 e_2^2 \cos 2\omega_2 t \tag{Eq. A-5}$$

$$- \frac{1}{4} k_3 e_1^3 \sin 3\omega_1 t \tag{Eq. A-6}$$

$$- \frac{1}{4} k_3 e_2^3 \sin 3\omega_2 t \tag{Eq. A-7}$$

$$+ k_2 e_1 e_2 \cos(\omega_1 - \omega_2)t \quad (\text{Eq. A-8})$$

$$- k_2 e_1 e_2 \cos(\omega_1 + \omega_2)t \quad (\text{Eq. A-9})$$

$$+ \frac{3}{4} k_3 e_1^2 e_2 \sin(2\omega_1 - \omega_2)t \quad (\text{Eq. A-10})$$

$$- \frac{3}{4} k_3 e_1^2 e_2 \sin(2\omega_1 + \omega_2)t \quad (\text{Eq. A-11})$$

$$+ \frac{3}{4} k_3 e_1 e_2^2 \sin(2\omega_2 - \omega_1)t \quad (\text{Eq. A-12})$$

$$- \frac{3}{4} k_3 e_1 e_2^2 \sin(2\omega_2 + \omega_1)t \quad (\text{Eq. A-13})$$

Equations A-2 and A-3 are directly proportional to the input signals when the amplifier is operated within its linear region. Therefore, the fundamental response can be plotted with a slope of 1. Equations A-4, A-5, A-8, and A-9 are second order terms, are proportional to the square of the input signals, and can be plotted with a slope of 2. Equations A-6, A-7, A-10, A-11, A-12, and A-13 are proportional to the cube of the input and can be plotted with a slope of 3.

In general, only equations A-2, A-3, A-10, and A-12 need to be considered for TM preamplifiers. All other components are far removed from the input signals and are easily removed by filtering. Equations A-2 and A-3 indicate the output of the device for the desired signals; however, it should be noted that in addition to the linear gain term ( $k_1$ ), the desired output is modified by the third-order coefficient ( $k_3$ ).

Equations A-10 and A-12 of the series expansion are of major concern in the TM preamplifier. These IM products are located as close to the input signals as the two input signals are from each other.

The above analysis has been simplified by considering the effect of only two signals, the inclusion of only the first three terms of the power series, and the assumption that the bandwidth is less than  $2\omega_1$ . In wide-band systems, if higher order terms are even, the IM products are of little concern in amplifiers, because they are far removed from the desired frequency. If the terms are odd, some of the IM components will fall very near the desired frequency. Fortunately, the higher order coefficients (fifth order or greater) have considerably smaller values and are normally neglected. As more signals are added, the number of IM products increases very rapidly. For example, if the number of signals is increased from two to three, the number of the IM products close to the desired frequency increases from two to nine. The number of potentially dangerous IM products is approximately proportional to the cube of the number of signals.

If two signals of equal amplitude are applied to the input of an amplifier of sufficient bandwidth at frequencies  $f_1$  and  $f_2$ , the output spectrum may appear as shown in [Figure A-1](#). The second order products will appear at  $2f_1$ ,  $2f_2$ ,  $f_1 + f_2$ , and  $f_1 - f_2$ . The third-order products will appear at frequencies  $3f_1$ ,  $3f_2$ ,  $2f_1 - f_2$ ,  $2f_1 + f_2$ ,  $2f_2 - f_1$ , and  $2f_2 + f_1$ . The third-order terms,  $2f_1 - f_2$  and  $2f_2 - f_1$ , may be within the passband of a TM preamplifier if the bandwidth is greater than  $3(f_2 - f_1)$ .



<b>NOTE</b> 	Amplifiers with bandwidths greater than one octave should be tested for second order terms.
--	---

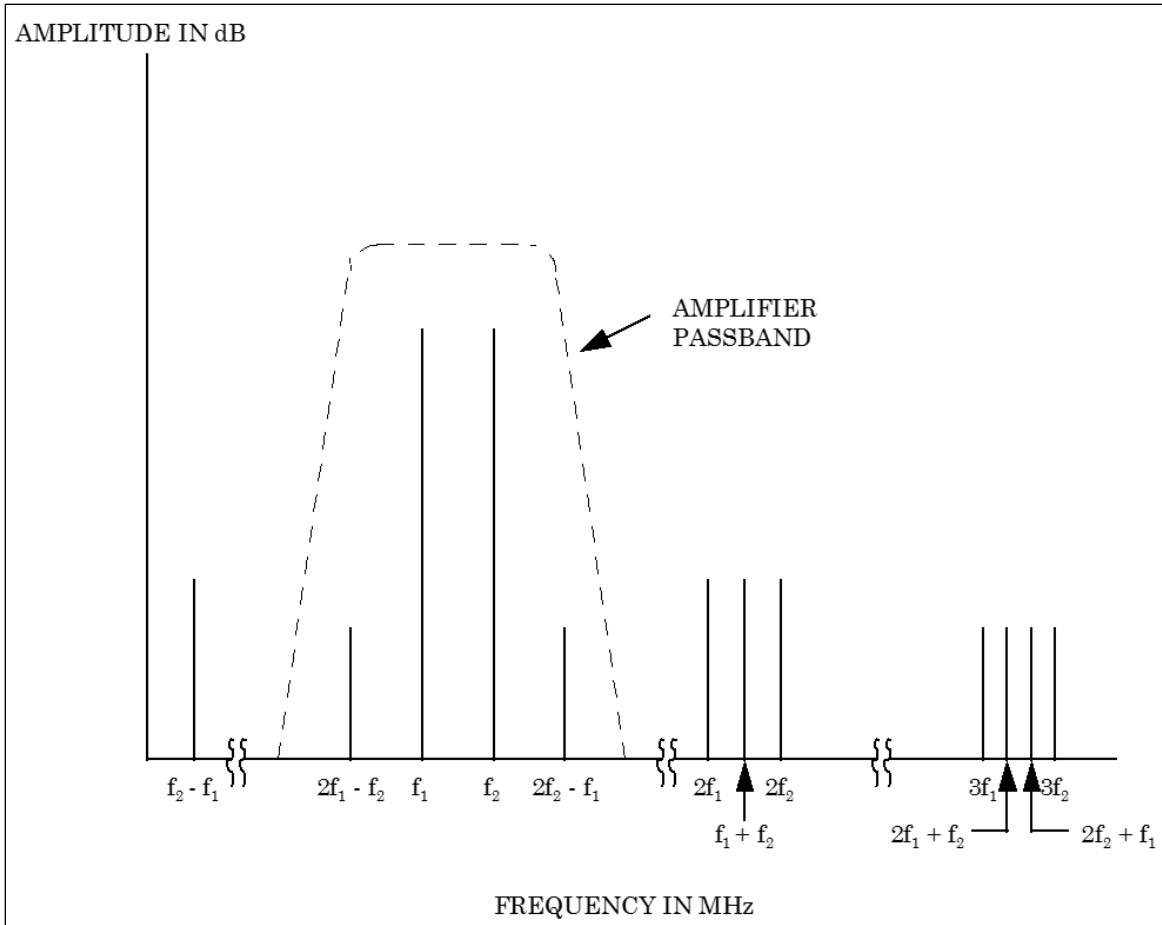

Figure A-1. Illustration of Spectrum for Two Fundamental Frequencies, F1 and F2, with Second- and Third-Order Response

### A.3 Intercept Point

The amount of IM distortion in a system can be defined from the third-order IP. For each 1 dB of signal strength increase of the fundamental frequency, the third-order level increases 3 dB.<sup>17</sup> The IP is defined as the intersection of the fundamental response of an amplifier and the higher order spurious responses extrapolated to a linear response and referred to the amplifier output. [Figure A-2](#) illustrates a plot of the amplifier transfer characteristics including second and third-order IM terms.

<sup>17</sup> Keiser, Bernhard E. *Broadband Coding, Modulation, and Transmission Engineering*, second edition. Washington, D.C.: CEEPress Books, 1994.

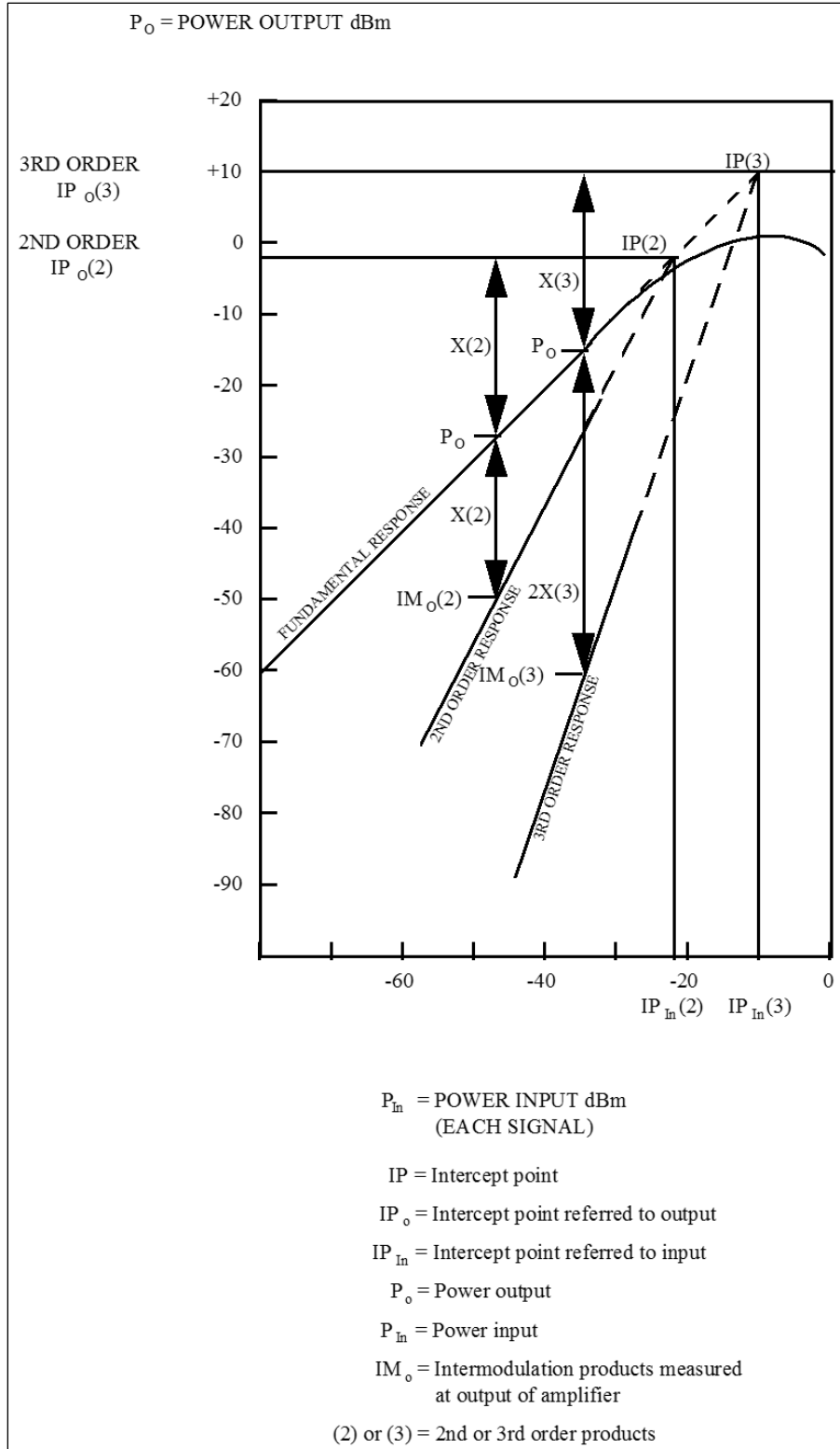

Figure A-2. Graphical Representation of Intercept Point

Once the IP has been experimentally determined, it is possible to predict a range of operation where the second and third-order terms will not be greater than the system noise floor

if the minimum detectable signal is known. This range is known as the Spurious Free Dynamic Range, which is defined as the range that exists between two or more signals of equal amplitude and the IM products that result from these signals.

From [Figure A-2](#), the following relationships can be established.

- a. Power output of second-order terms.

$$P_{o2} = 2(IP_2 - P_0) \text{ dB below } IP \quad (\text{Eq. A-14})$$

Where:

$IP_2$  = second-order IP

$P_0$  = fundamental signal level measured at amplifier output

- b. Power output of third-order terms.

$$P_{o3} = 3(IP_3 - P_0) \text{ dB below } IP \quad (\text{Eq. A-15})$$

Where:

$IP_3$  = third-order IP

- c. Third-order output IP.

$$IP_{03} = (P_0 - IM_{03}) + IM_{03} \quad (\text{Eq. A-16})$$

Where:

$IM_{03}$  = third-order IM at output of amplifier.

- d.  $X(3) = IP_3 - P_0$  (Eq. A-17)

- e. Dynamic range if system minimum detectable signal is known.

$$2X(3) = P_0 - IM_{03} \quad (\text{Eq. A-18})$$

This page intentionally left blank.

## Appendix B

### Noise Figure Measurements

#### B.1 General

The following discussion reveals several areas where special care and attention are necessary to obtain valid and meaningful noise figure measurements. The most common method for measuring noise figure, and the method that will be discussed here, is the automatic noise figure meter method. Automatic noise figure measurements are generally valid for noise figures ranging from about 3 dB to as much as 20 dB, if proper precautions and care are taken during the measurement process. This range of noise figure values will include all the TM RF components except very low noise preamplifiers. Measurement for that type of equipment is generally made using a laboratory environment and a hot-and-cold-source test method. Total RF system sensitivity can be evaluated using solar measurement methods.

#### B.2 Noise Power

The noise power at the output of a TM receiving system can be expressed by

$$N \propto k T_s B \quad (\text{Eq. B-1})$$

Where:

$$k = \text{Boltzmann's constant} = 1.380622 \cdot 10^{-23} \text{ W/Hz/K}$$

$$T_s = \text{system noise temperature (K)}$$

$$B = \text{system bandwidth (Hz)}$$

The system noise power is proportional to the system noise temperature and the receiving system bandwidth. The best receiving system bandwidth can be determined from the data bandwidth, modulation type, and peak deviation. The actual bandwidth is determined by what receiver bandwidths are available. The sensitivity of a TM receiving system is ultimately determined by the amount of noise the system adds to the incoming signal. Consequently, the design of the receiving system must include every possible design consideration to minimize this added noise. To evaluate the design and quality of any receiving system, it is necessary to include measurement of its performance in terms of noise temperature or noise figure.

#### B.3 System Consideration

Several parameters in a receiving system are significant when determining the noise figure of that system. The first amplifier stage in the receiving system establishes the order of magnitude of the noise figure of the system; however, every component from the receiving system input terminals to its output will have an effect on the amount of noise added to a signal by the receiving system. Included are such parameters as cable loss, connector loss, impedance mismatch, insertion loss of passive devices (switches, filters, and directional couplers), and the noise introduced by all active devices within the receiving system.

#### B.4 Noise Figure Equation

At this point it is necessary to make a distinction between two forms of the term “noise figure.” Noise figure ( $NF_{dB}$ ) is expressed in dB and noise factor ( $n_f$ ) in decimal units. For

example, a noise figure of 3 dB corresponds to a noise factor of 2. A noise figure calculation is the logarithm form of the numerical power ratio (that is, the noise factor). To eliminate possible confusion, equations B-2 and B-3 shows the relationship between the two.

$$NF_{dB} = 10 \cdot \log_{10}(n_f) \quad (\text{Eq. B-2})$$

$$n_f = 10^{(NF/10)} \quad (\text{Eq. B-3})$$

The equation for calculating the noise factor of an RF system or any series of networks in cascade follows:

$$n_s = n_1 + \frac{n_2 - 1}{g_1} + \frac{n_3 - 1}{g_1 g_2} \dots + \frac{n_n - 1}{g_1 g_2 \dots g_{n-1}} \quad (\text{Eq. B-4})$$

Where:

- $n_s$  = system noise factor
- $n_1, n_2, n_n$  = noise factor of each stage
- $g_1, g_2, g_n$  = gain of each stage expressed in decimal units

For a lossy component, the noise factor is the reciprocal of the fractional gain at room temperature (for example 290°). The test setup should also have good impedance matching. From (B-2) and (B-3), the noise factor is equal to the loss, expressed as:

$$n_c = l_c \quad (\text{Eq. B-5})$$

$$n_c = 10^{(1 \text{ dB}/10)} = 1.2589$$

Equations B-5 and B-7 verify that the gain and noise figure of the initial amplifying stage in a receiving system has a significant effect on the noise figure of that system. As previously stated, the overall design and quality of construction can affect the system noise figure as well. The system in [Figure B-1](#) with the RF system components located at some point separate from the antenna will have a worse noise figure than the system in [Figure B-2](#) with the RF components located at the feed assembly output terminals. Substituting the values from [Figure B-1](#) into equation B-4 and using equation B-2, the system noise figure can be determined. The equations assume the cable losses except  $C_1$  are negligible.

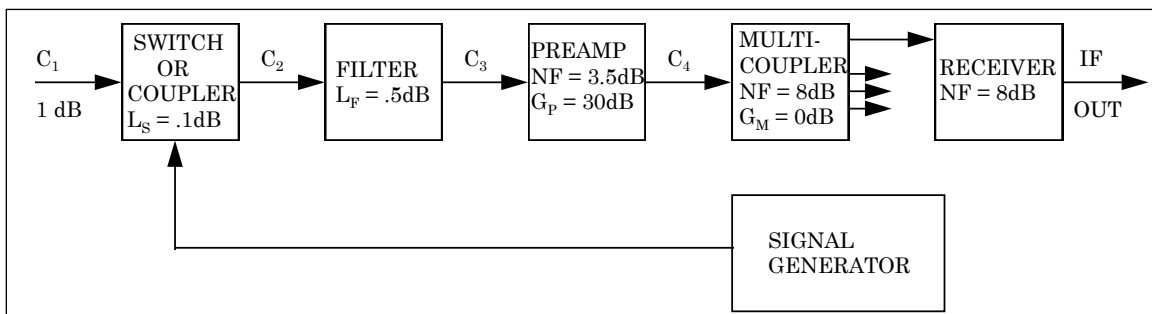

Figure B-1. Receiving System with Filter before the Preamplifier

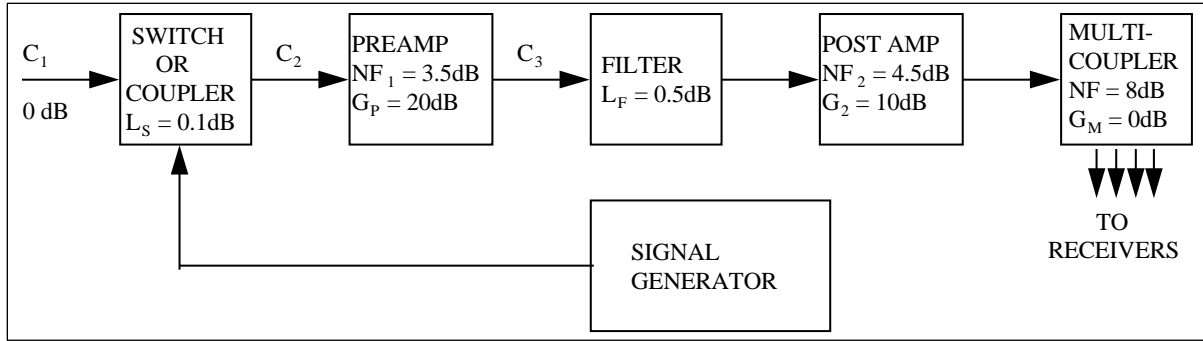

Figure B-2. Receiving System with Filter after Preamplifier

Equations B-4 and B-5 for [Figure B-1](#) are as follows.

	cable	switch	filter	preamp	m/c	receiver
$n =$	$nc_1$	$+ \frac{n_s - 1}{g_{c1}}$	$+ \frac{n_f - 1}{g_{c1}g_s}$	$+ \frac{n_p - 1}{g_{c1}g_s g_f}$	$+ \frac{n_m - 1}{g_{c1}g_s g_f g_p}$	$+ \frac{n_r - 1}{g_{c1}g_s g_f g_p g_m}$

From (B-4) and (B-5),

$$n = nc_1 + nc_1 (n_s - 1) + nc_1 n_s (n_f - 1) + nc_1 n_s n_f (n_p - 1) + nc_1 n_s n_f \frac{(n_m - 1)}{g_p} + nc_1 n_s n_f \frac{(n_r - 1)}{g_p g_m}$$

Where:

$$nc_1 = 10(1/10) = 1.2589 \text{ (cable)}$$

$$n_s = 10(0.1 / 10) = 1.02329 \text{ (switch)}$$

$$n_f = 10(0.5/10) = 1.122 \text{ (filter)}$$

$$n_p = 10(3.5/10) = 2.2387; g_p = 10(30/10) = 1000 \text{ (preamp)}$$

$$n_m = 10(8 / 10) = 6.3095; g_m = 100/10) = 1 \text{ (multicoupler)}$$

$$n_r = 10 (8/10) = 6.3095 \text{ (receiver)}$$

$$n = 3.463$$

$$NF = 10 \cdot \log_{10} (3.463)$$

$$NF = 5.114 \text{ dB}$$

When substituting the values from [Figure B-2](#) into (B-5) we get:

$$n = nc_1 + nc_1 (n_s - 1) + nc_1 n_s (n_p - 1) + nc_1 n_s \frac{(n_f - 1)}{g_p} + nc_1 n_s n_f \frac{(n_1 - 1)}{g_p} + nc_1 n_s n_f \frac{(n_m - 1)}{g_p g_1} + nc_1 n_s n_f \frac{(n_r - 1)}{g_p g_1 g_m}$$

Where:

$$nc_1 = 10^{(0/10)} = 1 \text{ (cable c1)}$$

$$n_s = 10(0.1 / 10) = 1.02329 \text{ (switch)}$$

$$n_p = 10(3.5 / 10) = 2.2387; g_p = 10(20/10) = 100 \text{ (preamp)}$$

$$n_1 = 10(4.5 / 10) = 2.8194; g_1 = 10(10/10) = 10 \text{ (post amp)}$$

$$n_m = 10(8 / 10) = 6.3095; g_m = 10(0/10) = 1 \text{ (multicoupler)}$$

$$\begin{aligned}n_r &= 10(8/10) = 6.3.95 \text{ (receiver)} \\n &= 2.3252 \\NF &= 10 \cdot \log_{10}(2.3252) \\NF &= 3.665 \text{ dB}\end{aligned}$$

This example underscores the importance of minimizing loss components ahead of the first amplifier stage. Placement of filters and calibration components, as well as long cable runs, should be given careful consideration in system design. Although, in this example, interconnecting cable losses were neglected. Long cable runs can have a significant impact on system performance. For an accurate noise factor calculation, the losses between stages should be included. This combined noise factor is, in turn, employed to determine the noise figure used in equation B-2. The above calculations are based on room temperature (290 K) and correct impedance matching. For low noise figure components and amplifiers, the noise figure is not a useful approach. Instead, the effective noise temperature ( $T_e$ ) should be used. The cascaded approach used for noise factor can also be used as indicated in the following equations:

$$T_e = \frac{T(1 - g_a)}{g_a} \quad (\text{Eq. B-6})$$

And

$$1 = \frac{1}{g_a} \quad (\text{Eq. B-7})$$

Where:

- $T_e$  = effective noise temperature in Kelvin
- $T$  = component noise temperature
- $g_a$  = gain of the component (available loss of the component)
- 1 = available loss (numeric equivalent of the dB value).

## B.5 Noise Figure Measurements

Each brand of noise figure measuring equipment requires unique procedures and techniques for operation. The operations manual for the noise figure meter should be consulted before making measurements. A variety of precautions must be observed when making noise figure measurements with an automatic noise figure meter to avoid mistakes and to improve accuracy.

### B.5.1 Noise Source

Noise figure measurements at TM frequencies most commonly employ a diode. However, older noise figure meters typically used a gas discharge tube. This device has characteristics that can damage sensitive amplifiers and degrade results. When the noise tube is initially turned on, it produces an output spike that is significant. Prior to turning on the noise source, it is necessary to disconnect it from the device under test. After it is turned on, it may be reconnected to the device under test. In operation, the noise tube is pulsed on and off. A high voltage ionizing pulse of several thousand volts is required. Capacitive coupling between the noise tube and the noise pickup coil allows these pulses to appear as spikes in the noise output at an amplitude of several volts. The use of an attenuator on the noise source output reduces these



effects. The attenuator will also improve the VSWR match between the noise source and the device under test. Selection of this attenuator can be of further benefit to the operator. The accuracy of most automatic noise figure meters falls off when measuring noise figure below 2 or 3 dB. Since all attenuation ahead of an active device adds algebraically to the noise figure of that device, the use of a 10-dB attenuator will increase the measured noise figure by 10 and make subtracting this loss from the final reading easier. A 10-dB attenuator is also sufficient to protect most sensitive amplifiers from these spikes.

#### B.5.2 Excess Noise Ratio

Automatic noise figure meter accuracy is dependent upon the ENR of the noise source being used. The meter provides a reading based on its calibration and the ENR of the source at the desired frequency. When the ENR of the source is different from that for which the meter was calibrated, a correction factor must be added to the meter reading. Some noise figure meters are calibrated during the measurement process for the noise source and frequency used. In these meters, no correction is required. The operator must always consult the operations manual to determine the correction factor for the source and frequency used.

#### B.5.3 Gain

Another common error in making noise figure measurements is the lack of appropriate gain within the test setup. Too much gain will saturate the noise figure meter and cause an erroneous reading. Likewise, too little gain will affect the readings. The operations manual for the meter used should be consulted to obtain the proper input level for that meter. This condition is most effectively accomplished by placing an attenuator or amplifier in the output of the mixer stage, just ahead of the noise figure meter. A 60-dB step attenuator or a variable gain IF amplifier with up to 40-dB gain is sufficient for most applications.

#### B.5.4 Component Loss

Connectors and cables used in the test setup can cause many problems. Quality components must always be used to obtain quality test results from any test setup. In noise figure measurements, this statement is doubly true. Not only must components be first quality, they must be kept clean and tightened properly for accurate measurement. A Freon cleaner is preferred because lubricating contact cleaners attract dust and residue. All test cables should be carefully calibrated in the frequency range in which they are to be used. Cable losses will be added to the noise figure of the amplifier or receiver that they precede when making system noise figure calculations.

#### B.5.5 Image Response

When selecting the equipment for a noise figure test setup, it is important to choose a receiver or converter that has a high image rejection specification. The image response of the receiver adds significantly to the noise figure. The image error is given by equation B-8 below.

$$NF_1 = 10 \cdot \log_{10} \left( 1 - \frac{g_i}{g_s} \right) \quad (\text{Eq. B-8})$$

Where:

- $g_i$  = image response gain ratio
- $g_s$  = signal response gain ratio

For receivers with an image rejection of 20 dB or greater, this error is negligible. If a standard TM receiver is used as the converter, the image error can usually be neglected, but with a mixer converter, it must be taken into account. The image error of a mixer converter can be improved by using a narrow band filter (5 MHz or less) at the input to the mixer. If the image rejection of the filter is greater than 20 dB, the image error can be neglected.

## B.6 Measurement Setup

Connect the test equipment for laboratory measurements of component noise figure as shown in [Figure B-3](#). Noise figure measurements on TM equipment are generally made easier by using a standard TM receiver as the mixer-converter stage. The TM receiver eliminates image errors and the necessity for making frequency measurements on the local oscillator. Most TM receivers have an IF output at the noise figure meter input frequency. Use of the first IF output is generally preferred because of the elimination of the second IF mixer and amplifiers. If a separate mixer converter and local oscillator are preferred, they will be connected as shown in [Figure B-4](#).

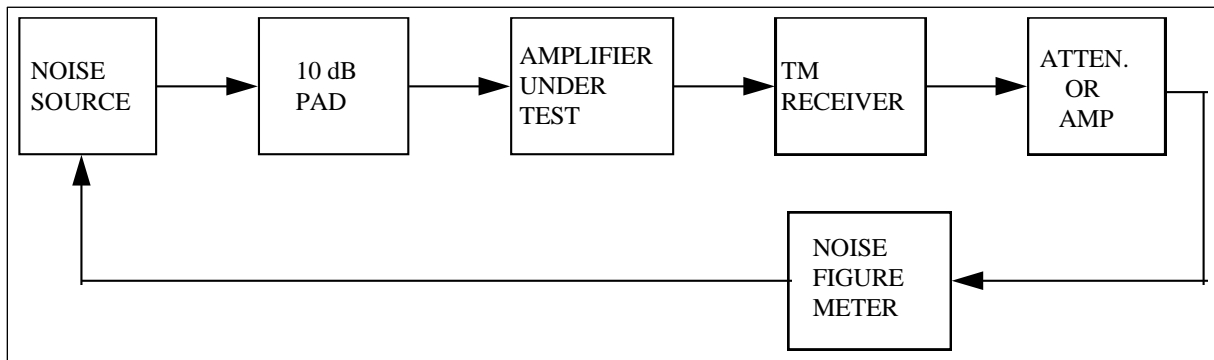

Figure B-3. Noise Figure Measurement using TM Receiver

**Note:** The 10-dB pad is optional if a noise diode is used.

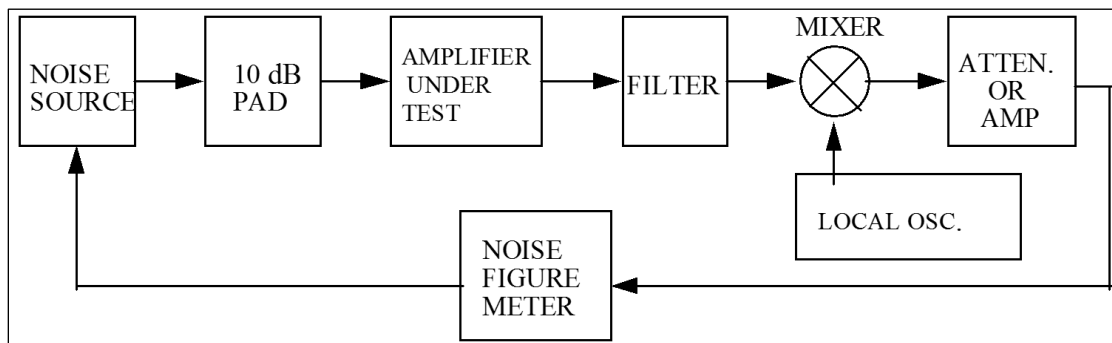

Figure B-4. Noise Figure using Filter, Mixer, and Oscillator

**Note:** The 10-dB pad is optional if a noise diode is used.



This connection should not be made until after the noise source is turned on. If this connection is made prior to turning on the noise source, the noise spikes discussed previously may damage the amplifier.

The equipment should be assembled and connected as shown except for the connection between the noise source and the amplifier under test. All equipment except the noise source should be allowed to warm up for at least 30 minutes. The noise source should not be turned on until measurements are to be made. The noise source should also be turned off when no measurements are taken for 10 or more minutes. If the noise tube is allowed to become hot, an error will be introduced. Noise figure readings above 2 dB will not be affected if the noise source remains near room temperature.

### B.7 Measurement Procedure

The first step in making noise figure measurements involves calibrating the system. This calibration is accomplished by replacing the amplifier under test with a jumper or barrel connector. Connect the jumper between the 10-dB pad and the next stage (in this case, a TM receiver). Turn the noise source on. Employing the manufacturer's procedures for the noise figure meter used, measure the noise figure. Take care to ensure that the attenuator or amplifier following the receiver is adjusted to provide the proper AGC voltage output from the noise figure meter. Record the measured noise figure in dB. The noise factor for the calibration setup is determined as follows:

$$n_{N/A} = n_P + n_P (n_2 - 1)$$

$$n_P (n_2 - 1) = n_{N/A} - n_P \quad (\text{Eq. B-9})$$

Where:

- $n_{N/A}$  = noise factor of system with no amplifier
- $n_P$  = noise factor of pad (10-dB pad in this case)
- $n_2$  = noise factor of next stage

With the noise source off and disconnected, place the amplifier under test in the test setup in place of the jumper. Turn on the noise source and connect it to the 10-dB pad. Again, ensure a proper noise figure meter AGC output and measure and record the noise figure. This reading will be the system noise figure ( $NF_s$ ). Equations B-2, B-4, and B-5 are now used to determine the noise factor ( $n_1$ ), and the noise figure ( $NF_1$ ) of the amplifier under test.

$$n_s = n_P + n_P(n_{amp} - 1) + \frac{n_P(n_2 - 1)}{g_{amp}} \quad (\text{Eq. B-10})$$

By substitution:

$$n_S = n_P = n_P(n_{amp} - 1) + \frac{(n_{N/A} - n_P)}{g_{amp}} \quad (\text{Eq. B-11})$$

$$n_{amp} = \frac{n_S}{n_P} - 1 \frac{(n_{N/A} - n_P)}{g_{amp}} \quad (\text{Eq. B-12})$$

The noise figure for the amplifier can now be determined by:

$$NF = 10 \cdot \log_{10} (n_{amp}) \quad (\text{Eq. B-13})$$

Where:

- $n_P$  = pad attenuation (10-dB)
- $n_{N/A}$  = noise factor without amplifier
- $n_{amp}$  = noise factor of amplifier :  $g_{amp}$  = gain factor of amplifier
- $n_2$  = noise factor of stage following the amplifier

If proper care has been taken to avoid the problem areas discussed previously,  $NF_1$  will be the noise figure of the amplifier under test within the accuracy of the noise figure meter used.

## B.8 Summary

Noise figure is a helpful tool in the design and evaluation of TM RF systems. The precautions necessary to make valid noise figure measurements are also necessary in the design of a quality RF system. By being aware of these problem areas, both the engineer and technician can do a better job. Careful measurement of the noise figure and gain of each active component, and the loss of each passive component (including cables and connectors), will enable calculation and determination of the system noise figure prior to making system measurements. A measured system noise figure, different from that calculated, usually indicates the existence of one or more of the problem areas discussed. Periodic noise figure measurements of at least twice a year can show a trend leading to a component failure. The frequent measurements of G/T can serve as a guide for deciding how often noise figure measurements should be made. Potential failures can be avoided by identifying such trends.

## Appendix C

### Solar Calibration

#### C.1 General

The solar calibration test is used as a basis for system calibration, go/no-go status, and troubleshooting of operational TM ground receiving systems. One of the primary advantages of the solar calibration test is the availability of the sun as a radiation source and its applicability to nearly any antenna with a 4-foot or larger aperture. For large-aperture antennas, aperture correction is required because the sun can no longer be treated as a point source.

#### C.2 Solar Calibration Technique

 <p><b>NOTE</b></p>	<p>The solar calibration method and procedures have been revised for tri-band accuracy (e.g., L, S, and C-Bands).</p> <p>The revised method has been adopted based on the recommendation from the Technical Memorandum titled: Comments on RCC-118-02, vol-2, App C – Solar Calibration.</p>
--	--

The solar calibration technique uses a measurement of the ratio ( $T_{\text{sun}}/T_s$ ) to calculate receiving system sensitivity, where  $T_{\text{sun}}$  is the antenna noise temperature referred to the antenna temperature because of the RF energy that is being collected from the sun, and  $T_s$  is the antenna system noise temperature.

By definition,

$$T_{\text{sun}} = \frac{S\lambda^2 G_r}{8\pi k k_2 L} \quad (\text{Eq. C-1})$$

Or

$$\frac{T_{\text{sun}}}{T_s} = \frac{S\lambda^2 G_r}{8\pi k k_2 L T_s} \quad (\text{Eq. C-2})$$

And

$$\frac{G_r}{T_s} = \frac{8\pi k k_2 L T_{\text{sun}}}{S\lambda^2 T_s} \quad (\text{Figure of Merit}) \quad (\text{Eq. C-3})$$

Where:

- $G_r$  = gain of the receiving antenna
- $\lambda$  = test frequency wavelength (meters) ( $300/f_i$ )
- $L$  = aperture correction factor
- $T_s$  = system noise temperature

- $k$  = Boltzmann's constant ( $1.380622 \cdot 10^{-23}$  W/Hz/K)  
 $k_2$  = correction factor for atmospheric attenuation  
 $S$  = solar power flux density (random polarization) in W/m<sup>2</sup>/Hz at the test time and at the test frequency  
 $f_t$  = test frequency (MHz)

 <p><b>NOTE</b></p>	<p>Solar power flux density (<math>S</math>) at the test frequency will need to be interpolated from data measured by NOAA at specific frequencies. Measurements are made daily by radio observatories at frequencies 245, 410, 610, 1415, 2695, 4995, 8800, and 15,400 MHz. Solar flux measurements from Sagamore Hill Radio Observatory are the optimal values for the continental United States. For sites outside of the continental United States, use values from the nearest radio observatory.</p> <p>Contact information:          Phone: DSN 272-8087 or commercial (402) 232-8087          Internet: <a href="http://www.swpc.noaa.gov/ftpdir/lists/radio/rad.txt">http://www.swpc.noaa.gov/ftpdir/lists/radio/rad.txt</a> or  <a href="http://services.swpc.noaa.gov/text/current-space-weather-indices.txt">http://services.swpc.noaa.gov/text/current-space-weather-indices.txt</a></p>
--	---

Data interpolation is needed to convert the power flux density measurements into flux densities at the test frequency. A polynomial can be fit to the data set to perform this interpolation.

To encompass all telemetry bands, the outer frequencies required are 610 and 8800 MHz, with 1415 (L), 26(5 (S), and 4995 (C) data measurements in between. Annotate the solar flux values at these frequencies for use in the polynomial curve.

 <p><b>NOTE</b></p>	<p>To generate the polynomial, input the solar power flux measurements provided by NOAA for the frequencies identified above in Microsoft Excel or equivalent spreadsheet software.</p>
--	---

Input the five solar flux values annotated above into the spreadsheet software and create a scatter chart. Using trend line analysis, fit a 4<sup>th</sup>-order polynomial to the set of solar flux values. Then display the polynomial function fitting the solar flux values and corresponding coefficients on the chart.

General 4<sup>th</sup>-order polynomial form:

$$\text{Solar Flux } (S) = A + bf + cf^2 + df^3 + ef^4 \quad (\text{Eq. C-4})$$

Using the displayed equation generated by the spreadsheet software, solve Eq. C-4 for the solar flux density at the desired test frequency.

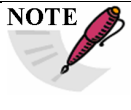
 <p><b>NOTE</b></p>	<p>This interpolation assumes that the test frequency is between 610 MHz and 8800 MHz.</p> <p>Input the NOAA measurement frequencies into the spreadsheet software using units of GHz to generate an equation with enough significant figures in the polynomial coefficients Trend Line display to obtain an accurate interpolated frequency value.</p>
--	---

The units of the measured power flux densities are  $10^{-22}$  W/m<sup>2</sup>/Hz. A reported value of 111 would mean  $111 \cdot 10^{-22}$  W/m<sup>2</sup>/Hz.

Aperture correction depends on the ratio of the angular size of the sun and the 3-dB beam width of the antenna. For simultaneous lobing, the following equation applies:

$$L = 1 + 0.18 \left[ \frac{\Phi_d}{\Phi_h} \right]^2 \text{ for } \frac{\Phi_d}{\Phi_h} \leq 1 \quad (\text{Eq. C-5})$$

Where:

$\Phi_d$  = angle subtended by the sun (approximately 0.53°)

$\Phi_h$  = 3-dB beam width of the sum channel

For con-scan antennas (when used with con-scan OFF), the following equation applies:

$$L = \left[ 1 + 0.38 \left[ \frac{\Phi_d}{\Phi} \right] \left[ \frac{\frac{P_M}{P} - 1}{\frac{P_T}{P_1} - 1} \right] \right] \quad (\text{Eq. C-6})$$

Where:

$\Phi_d$  = angle subtended by the sun

$\Phi_h$  = 3-dB beam width of the antenna with the con-scan OFF

$P_M$  = maximum IF output power, antenna on sun with con-scan OFF

$P_T$  = maximum IF output power, antenna on the sun with con-scan ON

$P$  = IF output power, antenna on cold sky with con-scan OFF

$P_1$  = IF output power, antenna on cold sky with con-scan ON

Equation C-5 should be used to calculate the aperture correction factor when con-scan is ON.

The correction factor for atmospheric attenuation is represented as:

$$K_2 = A_g / \sin \alpha \text{ (units in dB)} \quad (\text{Eq. C-7})$$

Where:

$A_g$  = gaseous absorption in the atmosphere in dB (0.033 dB for L-band and 0.035 dB for S-band)

$\alpha$  = elevation angle

or:

$$k_2 = 10^{A_g / (10 \cdot \sin(\alpha))} \text{ (numeric)} \quad (\text{Eq. C-8})$$

The SNR at the receiver final IF output is dependent on the received signal power ( $J_a$ ), the gain of the receiving antenna ( $G_r$ ) and the system noise temperature ( $T_s$ ). The relationship between the SNR and  $G/T$  is

$$\text{SNR} = \frac{J_a \lambda^2 G_r}{4 \pi k k_2 B T_s} \quad (\text{Eq. C-9})$$

Where:

$k$  = Boltzmann's constant ( $1.380622 \cdot 10^{-23}$  W/Hz/K)

$k_2$  = correction factor for atmospheric attenuation

$B$  = noise bandwidth of the final IF

$J_a$  = RF signal power flux density (watts/meter<sup>2</sup>)

$\lambda$  = test frequency wavelength (meters)

$G_r$  = gain of receiving antenna

$T_s$  = system noise temperature

Therefore, by performing the solar calibration test, the figure of merit of the antenna system can be determined, and the SNR at the output of the final IF can be calculated.

### C.3 Test for Receiving System Linearity

This test should be performed to determine if the TM system is linear from the input to the preamplifier through the power meter (or true rms voltmeter).

Set up the receiving system as shown in [Figure C-1](#).

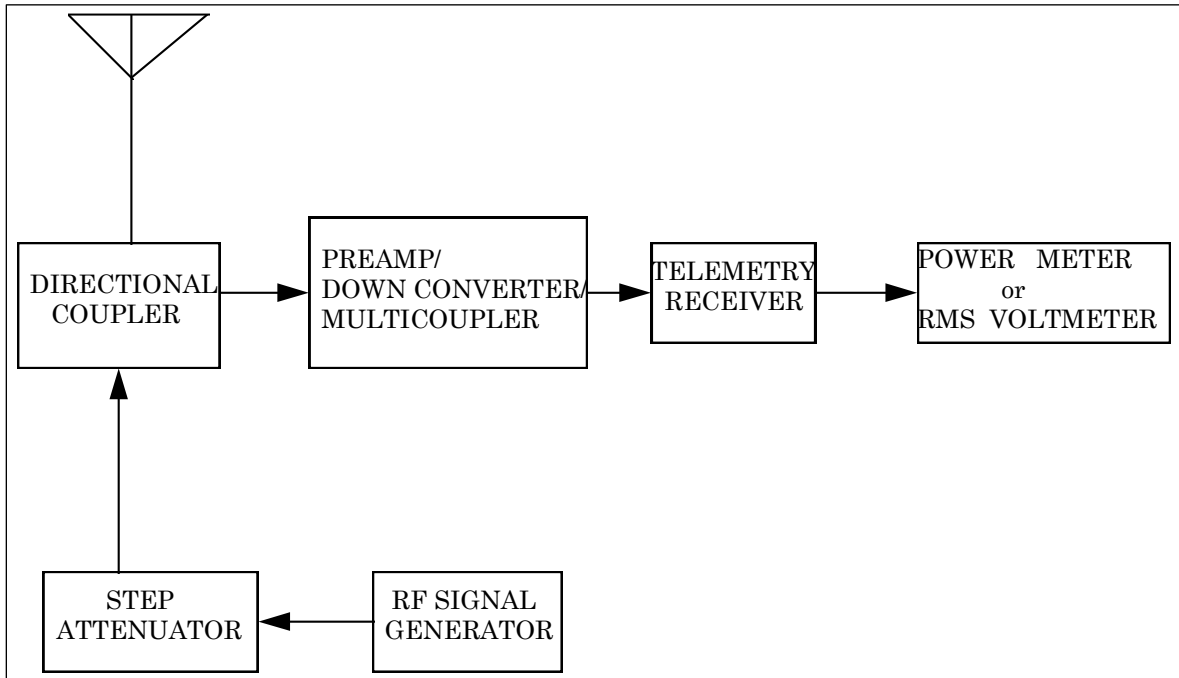

Figure C-1. Block Diagram for System Linearity Test

Point the antenna at the cold sky (at least several beam widths away from the sun with an elevation angle greater than 50°). Set the output of the signal generator to the minimum level and



the attenuator to maximum attenuation. Verify that no extraneous radio sources are present. Set the MGC so that the linear IF output is approximately equal to the output under AGC control. Record the power meter (or true rms voltmeter) reading ( $P_n$  or  $V_n$  as appropriate) in dB.

Let  $P_1$  ( $V_1$ ) represent the power meter (or true rms voltmeter) reading. The signal generator output is set to minimum level  $P_1 = P_n$  ( $V_1 = V_n$ ).

Set the step attenuator to 5-dB attenuation. Increase the signal generator output power until the power meter (or true rms voltmeter) reading has increased by approximately 3 dB. Record the power meter (or true rms voltmeter) reading (in dB). Decrease the attenuator in 1-dB steps and record the power meter (or true rms voltmeter) readings.

To test for linearity, plot  $10 \log_{10} (10^x - 1)$  (IF SNR) versus change in power at attenuator output (actual attenuation not attenuator setting) where  $x$  is the increase in power meter (or true rms voltmeter) reading (in dB) relative to  $P_n$  divided by 10; that is,  $x = (P_1 - P_n) / 10$ . A sample plot is shown in [Figure C-2](#). The maximum departure from a unity slope line should not exceed 0.5 dB.

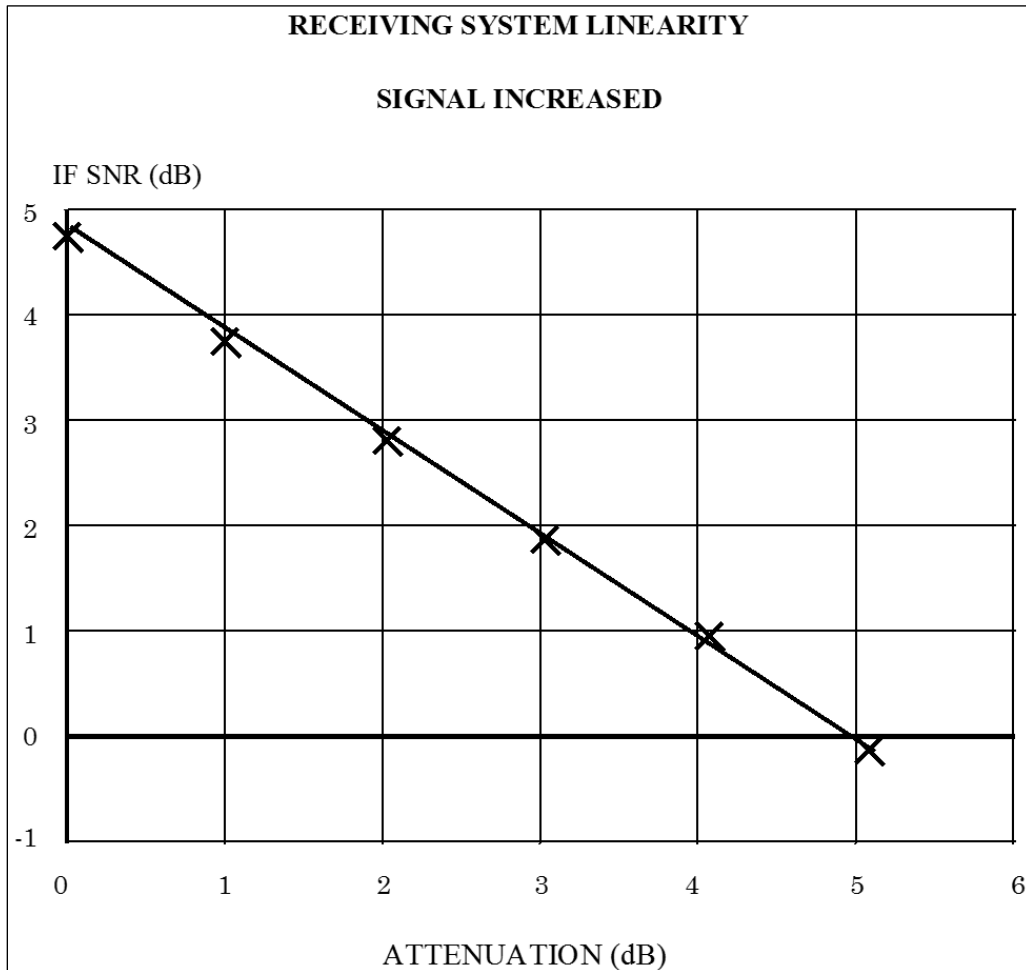

Figure C-2. IF SNR versus Attenuation

This page intentionally left blank.

## Appendix D

### Citations

- Ashley, C. G. and E. R. Hill. Diversity Combiner Characterization Preliminary Test Report. TP-72-13. Pacific Missile Test Center, Point Mugu, California, 12 April 1972.
- Department of Defense. *Requirements for the Control of Electromagnetic Interference Characteristics of Subsystems and Equipment*. MIL-STD-461G. 11 December 2015. May be superseded by update. Retrieved 28 May 2020. Available at [https://quicksearch.dla.mil/qsDocDetails.aspx?ident\\_number=35789](https://quicksearch.dla.mil/qsDocDetails.aspx?ident_number=35789).
- Keiser, Bernhard E. *Broadband Coding, Modulation, and Transmission Engineering*, second edition. Washington, D.C.: CEEPress Books, 1994.
- Kip Temple. “Some Thoughts on Testing the Data Quality Metric”. In *International Telemetry Conference Proceedings*, October 2022.
- Kraus, J. D. *Radio Astronomy*. New York: McGraw-Hill, 1966.
- Range Commanders Council. “Dynamic Multipath Channel Model for Aeronautical Mobile Telemetry.” Appendix 2H in *Telemetry Standards*. RCC 106-22. May 2022. May be superseded by update. Retrieved 13 May 2022. Available at <https://www.trmc.osd.mil/wiki/x/EoPOBg>.
- . “Frequency Considerations for Telemetry.” Appendix 2A in *Telemetry Standards*. RCC 106-22. May 2022. May be superseded by update. Retrieved 13 May 2022. Available at <https://www.trmc.osd.mil/wiki/x/EoPOBg>.
- . “Low-Density Parity-Check Codes for Telemetry Systems.” Appendix 2D in *Telemetry Standards*. RCC 106-17. July 2017. Superseded by RCC 106-22. Retrieved 13 May 2022. Available at <https://www.trmc.osd.mil/wiki/x/EIu8Bg>.
- . “Low-Density Parity-Check Codes for Telemetry Systems.” Appendix 2D in *Telemetry Standards*. RCC 106-22. May 2022. May be superseded by update. Retrieved 13 May 2022. Available at <https://www.trmc.osd.mil/wiki/x/EoPOBg>.
- . “Space-Time Coding for Telemetry Systems.” Appendix 2E in *Telemetry Standards*. RCC 106-22. May 2022. May be superseded by update. Retrieved 13 May 2022. Available at <https://www.trmc.osd.mil/wiki/x/EoPOBg>.
- . *Telemetry Applications Handbook*. RCC 119-06. May 2006. May be superseded by update. Retrieved 29 June 2021. Available at <https://www.trmc.osd.mil/wiki/x/h4u8Bg>.
- . *Telemetry Standards*. RCC 106-22. May 2022. May be superseded by update. Retrieved 13 May 2022. Available at <https://www.trmc.osd.mil/wiki/x/EoPOBg>.

- . “Use of Recommendation ITU-R M.1459 for Protection of...” Appendix 2F in *Telemetry Standards*. May 2022. Retrieved 5 October 2022. Available at <https://www.trmc.osd.mil/wiki/x/EoPOBg>.
- Rice, M., A. Davis, and C. Bettweiser. “Wideband Channel Model for Aeronautical Telemetry.” In *IEEE Transactions on Aerospace and Electronic Systems*, vol. 40, no. 1, pp. 57-69, January 2004.
- Rice, M. and J. Ebert. “Derivation and Analysis of the IRIG-106 Dynamic Multipath Channel Model.” In *Proceedings of the International Telemetry Conference*, Glendale, AZ, 26-29 October 2020.
- Robert Jefferis. “Link Availability and Error Clusters in Aeronautical Telemetry.” In *Proceedings of the International Telemetry Conference*, Las Vegas, NV, 25-28 October 1999.

## Appendix E

### References

- International Consultative Committee for Radio, Report 719-1, "Attenuation By Atmospheric Gases," in Volume V, *Propagation in Non-ionized Media, Recommendations and Reports of the CCIR*, 1978, pp. 97-102, International Telecommunications Union, Geneva, 1978.
- Freeman, R. L. *Telecommunication Transmission Handbook*. New York: J. Wiley, 6<sup>th</sup> edition.
- Ghais, A. F., E J. Ferrari, and C. J. Boardman. "Phase Linearity in Telemetry Reception." Paper presented during 3<sup>rd</sup> Annual International Telemetry Conference, Washington, D.C. 2-4 October 1967.
- . Study of Telemetry Recorder Phase Linearity Problems. ESD-TR 66-409. August 1966. ASCOM, Inc., Electronic Systems Division, AFSC Contract AF 19(628)5655, DDC No. AD 638685.
- Guidice, D. A. and J. P. Castelli. "The Use of Extraterrestrial Radio Sources in the Measurement of Antenna Parameters." *IEEE Transactions on Aerospace and Electronic Systems*, Volume AES-7 Issue 2, pp. 226-234. March 1971.
- Hedeman, W. R. "The Sun as a Calibration Signal Source for L- and S-Band Telemetry." Paper presented during 4<sup>th</sup> Annual International Telemetry Conference, Los Angeles, CA. 8-11 October 1968.
- Ko, H. C. "On the Determination of the Disk Temperature and the Flux Density of a Radio Source Using High Gain Antennas." *IRE Transactions on Antennas and Propagation*, Vol. 9, Issue 5, pp. 500-601, September 1961.

This page intentionally left blank.

## Appendix F

### Index of Tests

AGC dynamic - response to sine wave.....	4-18
AGC dynamic - response to square wave.....	4-13
AGC static.....	4-10
Amplifier gain compression.....	2-1
Amplifier intermodulation products and intercept point .....	2-8
Amplifier voltage standing wave ratio by return loss method.....	2-14
Antenna bore sight .....	1-22
Antenna gain .....	1-24
Antenna pattern.....	1-29
Automatic gain control stability.....	4-54
Bandwidth and passband gain characteristics.....	6-4
Bandwidth and small-signal power gain.....	2-5, 3-4
BER versus estimated BEP (DQM) with additive noise .....	11-3
BER versus estimated BEP (DQM) with adjacent channel interference.....	11-14
BER vs BEP for ctatic 3-Ray multipath channel conditions .....	11-21
BER vs BEP for static 2-Ray multipath channel conditions.....	11-26
Bit rate and input frequency tracking.....	7-7
Channel isolation .....	6-16
Combiner data frequency response.....	5-33
Combiner pre-detection carrier output.....	5-36
Data frequency response .....	4-51
Demodulator acquisition time and flat fade recovery time.....	7-9
Demodulator adjacent channel interference test.....	7-12, 9-20
Demodulator bit error probability versus $E_b/N_0$ .....	7-1
Diversity combiner break frequency.....	5-23
Diversity combiner dynamic evaluation with in-phase fading and equal RF signal strengths.....	5-10
Diversity combiner dynamic evaluation with periodic in-phase fading and unequal RF signal strengths .....	5-15
Diversity combiner dynamic evaluation with periodic out-of-phase fading and equal RF signal strengths .....	5-18
Diversity combiner dynamic evaluation with periodic out-of-phase fading and unequal RF signal strengths.....	5-20
Diversity combiner evaluation with random fading .....	5-25
Diversity combiner static evaluation with equal RF signal strengths.....	5-2
Diversity Combiner Static Evaluation with Unequal RF Signal Strengths .....	5-7
Downconverter intermodulation products and intercept point .....	6-7
DQM (BEP) resynchronization response.....	11-31

Dynamic tracking accuracy.....	1-19
Estimated BEP (DQM) step and dwell response .....	11-9
Feed assembly unit.....	1-30
FM capture ratio.....	4-21
FM receiver DC linearity and deviation sensitivity .....	4-61
Frequency modulation step response .....	4-39
Gain compression and saturation level .....	6-1
Image rejection.....	6-21
Impedance mismatch .....	2-20
Intermediate frequency signal-to-noise ratio linearity .....	4-8
LDPC-enabled transmitter/encoder to receiver/decoder interoperability .....	8-27
Local oscillator frequency accuracy and stability.....	6-24
Local oscillator radiation at downconverter input .....	6-27
Local oscillator radiation at RF input .....	4-30
Local oscillator stability.....	4-32
Multicoupler gain compression.....	3-1
Multicoupler intermodulation products and intercept point .....	3-7
Multicoupler VSWR by return loss method .....	3-14
Noise figure.....	3-18
Noise figure (downconverters) .....	6-14
Noise figure (receivers).....	4-6
Noise figure using automatic noise figure meter .....	2-17
Noise power ratio.....	4-24
Output isolation.....	3-22
PCM/FM demodulator modulation index sensitivity .....	7-15
Pedestal motion testing .....	1-41
Position loop .....	1-8
Position loop calibration .....	1-5
Pre-detection carrier output.....	4-59
Pre-detection combiner band pass frequency response using phase-modulated signal .....	5-27
Pre-detection combiner band pass frequency response using unmodulated signal .....	5-30
Pulse code modulation bit error rate .....	4-36
Rate loop .....	1-2
Re-acquisition and synchronization loss thresholds .....	7-5
Receiver adjacent channel interference .....	4-68
Receiver band pass frequency response using phase-modulated signal .....	4-45



Receiver band pass frequency response using unmodulated signal.....	4-41
Receiver band pass frequency response using white-noise input .....	4-49
Receiver phase noise .....	4-65
Receiver video spurious outputs .....	4-56
Receiver/decoder acquisition and flat fade recovery times.....	9-12
Receiver/decoder adjacent channel interference test .....	8-17
Receiver/decoder BEP versus $E_b/N_0$ .....	8-1
Receiver/decoder bit error probability versus $E_b/N_0$ .....	9-1
Receiver/decoder initial acquisition time and flat fade recovery time .....	8-10
Receiver/decoder latency time.....	8-14
Receiver/decoder reacquisition and synchronization loss thresholds .....	9-10
Receiver/decoder threshold.....	8-7
Receiver/equalizer link availability for dynamic channel 1 .....	10-13
Solar calibration using attenuator method .....	1-38
Solar calibration using linear receiver method .....	1-33
Spurious signal.....	6-19
Spurious signal response.....	4-2
STC signals with RF combining.....	9-32
STC-enabled transmitter/encoder to receiver/decoder interoperability .....	9-30
System bit error rate for static 2-ray channels .....	10-9
System bit error rate for static 3-ray channels .....	10-5
System link availability for dynamic channel 2.....	10-18
Tracking error voltage gradient .....	1-15
Transmitter 99% occupied bandwidth and $-25$ dbm bandwidth .....	9-23
Transmitter spectral mask compliance.....	9-27
Transmitter/encoder 99% occupied bandwidth and $-25$ -dbm bandwidth .....	8-20
Transmitter/encoder and receiver/decoder data latency .....	9-16
Transmitter/encoder spectral mask compliance.....	8-24
Velocity/acceleration measurement using strip chart recorder.....	1-11
Voltage standing wave ratio.....	6-11